



ECAT-2093

EtherCAT Three-Channel Incremental Encoder Counter

Features

- EtherCAT slave
- Three channels, 32-bit incremental encoder counters
- Encoder counting mode: CW/CCW , Pulse/Direction, A/B Phase
- Flexible channel assignment for Index counter latch function
- Position difference value for speed calculation
- Digital input filter
- Polarity setting by software for active high or active low encoder input
- EtherCAT:
 - 2 x RJ-45 bus interface
 - Supports Free-Run, SM synchron and Distributed Clock (DC) operation modes



Introduction

The EtherCAT slave ECAT-2093 is an incremental encoder counter which provides three independent high-speed counter channels. It reads the pulse train generated by an incremental encoder and can be used in positioning feedback applications. Each channel has two counter inputs. The inputs can either be single-ended or differential signals. Three counting modes are supported: clockwise/counterclockwise, pulse/direction and quadrant counting mode. The hardware index latch function allows the latching of encoder position of an assigned channel. The velocity calculation function provides the position difference updated every delta time. Low pass filter functions for filtering out electrical noises are provided.

Hardware Specifications

Item	Specification
Encoder	
Number of encoder inputs	3x encoder counter (A, B, Z), differential or single-ended
Resolution	32 Bit
Maximum input pulse frequency	4 MHz
Input level	5V (default) 12V/24V with internal resistor (set by jumper)
Photo-Isolation	2500 V _{DC}
LED Indicators	
Diagnostic LED	Power, EtherCAT status, signal status of each encoder input
Communication Interface	
Connector	2 x RJ-45
Protocol	EtherCAT
Distance Between Stations	Max. 100 m (100BASE-TX)
Data Transfer Medium	Ethernet/EtherCAT cable (Min. CAT5), shielded
Power	
Input Voltage Range	20 V _{DC} ~ 30 V _{DC}
Power Consumption	Maximum 4.5W
EMS Protection	
ESD (IEC 61000-4-2)	4 KV Contact for each channel
EFT (IEC 61000-4-4)	Signal: 1 KV Class A; Power: 1 KV Class A
Surge (IEC 61000-4-5)	1 KV Class A
Mechanical	
Installation	DIN-Rail
Dimensions (L × W × H mm)	110 mm × 90 mm × 33 mm (without connectors)
Case material	UL 94V-0 housing

Environment	
Operating Temperature	-25°C ~ +70°C
Storage Temperature	-30°C ~ +80°C
Relative Humidity	10 ~ 90%, No condensation

Table 1 : Technical data

■ Dimensions (Units: mm)

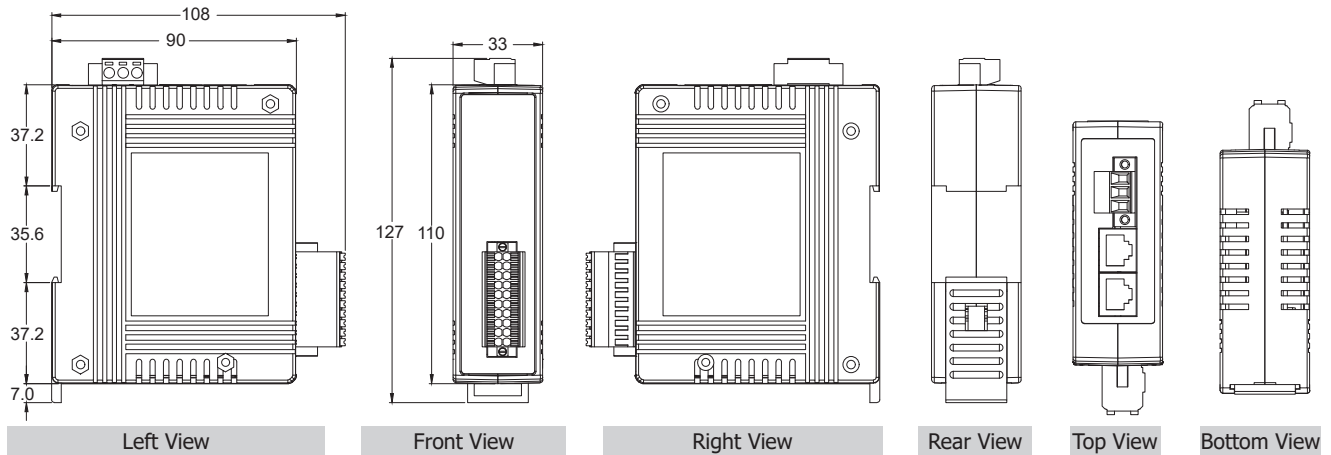
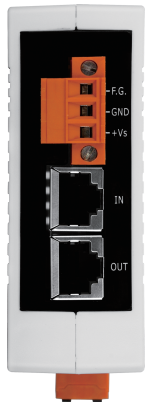

Figure 1 : Dimensions of the ECAT-2093

■ Connection Interfaces



Name	Signal
F.G	Frame ground
GND	Power supply: Ground 0V (from negative power contact)
+Vs	Power supply: +24 VDC (from positive power contact)
IN	EtherCAT signal input
OUT	EtherCAT signal output

Table 2 : ECAT-2093 power supply and EtherCAT interfaces

Figure 2 : ECAT-2093 side view with power supply and EtherCAT connection



Name	Signal	Signal Description	
A0+	Input	Encoder input A0+	Encoder Channel 0
A0-	Input	Encoder input A0-	
B0+	Input	Encoder input B0+	
B0-	Input	Encoder input B0-	
Z0+	Input	Encoder input C0+	Encoder Channel 1
Z0-	Input	Encoder input C0-	
A1+	Input	Encoder input A1+	
A1-	Input	Encoder input A1-	
B1+	Input	Encoder input B1+	Encoder Channel 2
B1-	Input	Encoder input B1-	
Z1+	Input	Encoder input C1+	
Z1-	Input	Encoder input C1-	
A2+	Input	Encoder input A2+	Encoder Channel 2
A2-	Input	Encoder input A2-	
B2+	Input	Encoder input B2+	
B2-	Input	Encoder input B2-	
Z2+	Input	Encoder input C2+	Encoder Channel 2
Z2-	Input	Encoder input C2-	

Figure 3 : ECAT-2093 front view with encoder inputs

Table 3 : Connection interfaces of the encoder counter

Wire Connections

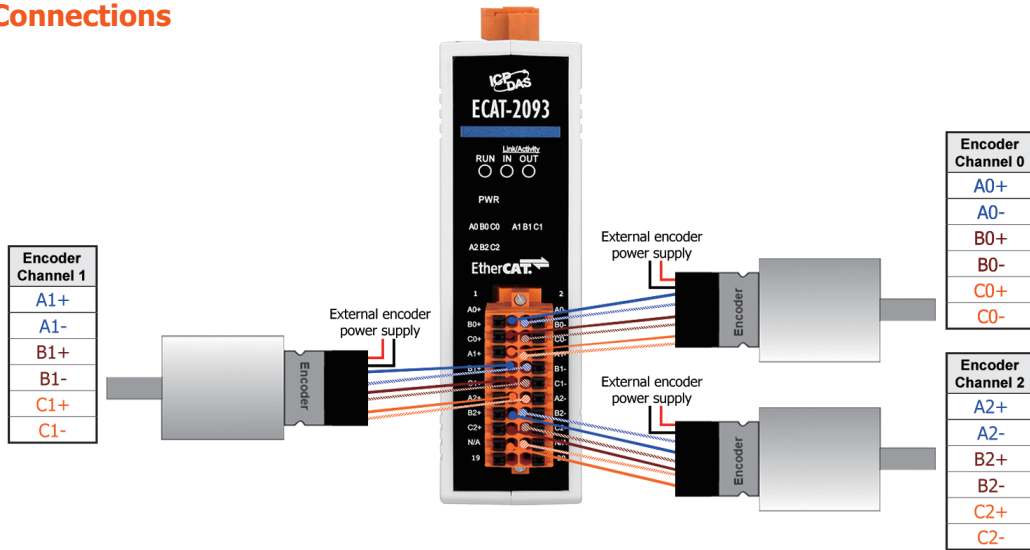

Figure 4 : ECAT-2093 connected to three differential encoder

Digital Input Channel

The ECAT-2093 can accept encoder input from either differential or single-ended signals.

By default it is set to support differential encoder signals as they are preferred due to their excellent noise immunity. For single-ended encoder connection the ECAT-2093 provides an internal 1k Ohm resistor for each signal input. The internal resistor can be selected via jumper setting.

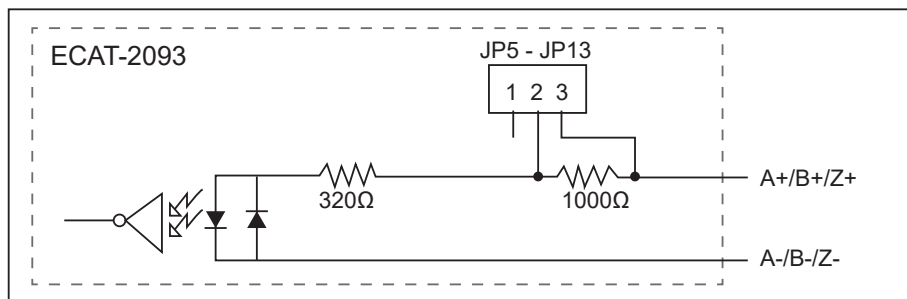
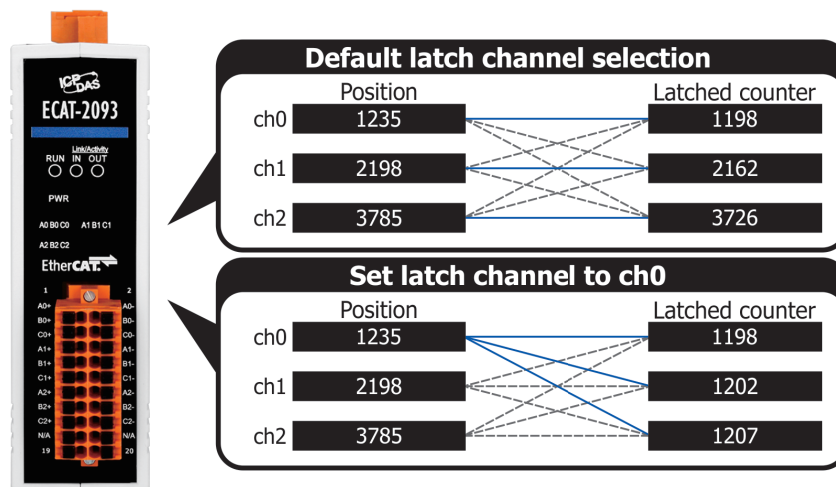

Figure 5 : Encoder input channel circuit

Flexible latch channel selection

ECAT-2093 can flexibly set the latched encoder for each channel. The latch function is preset to latch the encoder position corresponding to each channel when the event condition is triggered after it is enabled.

When there are special applications, such as measuring the warpage or flatness of the chip, the latch counter of the three channels can be assigned to the same encoder, and the latch input (phase C) of the three channels can be connected to the signal source that can trigger the latch event of the specified encoder, so that it can be used to latch three different positions of the same encoder.



Velocity calculation

ECAT-2093 provides the position difference (Vel_dP) value for estimating the velocity for each encoder channel. After setting the delta time (Vel_dT), user can calculate the current velocity based on the read back position difference. The adjustable range of the delta time is 0.5 ~ 32512.5 ms.

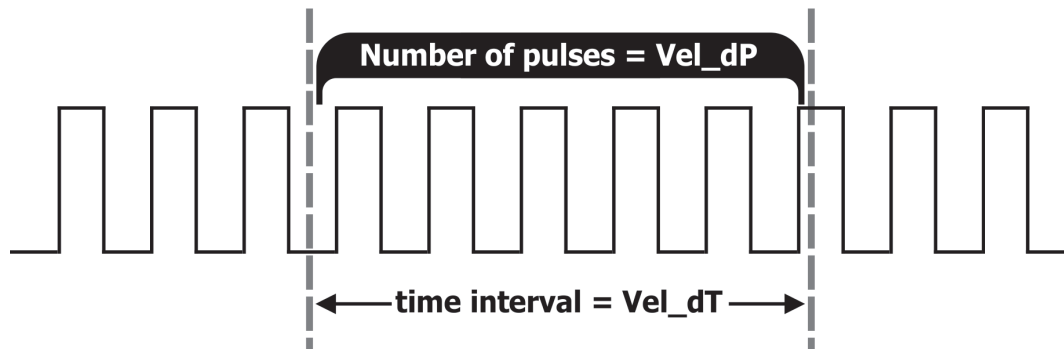

Applications

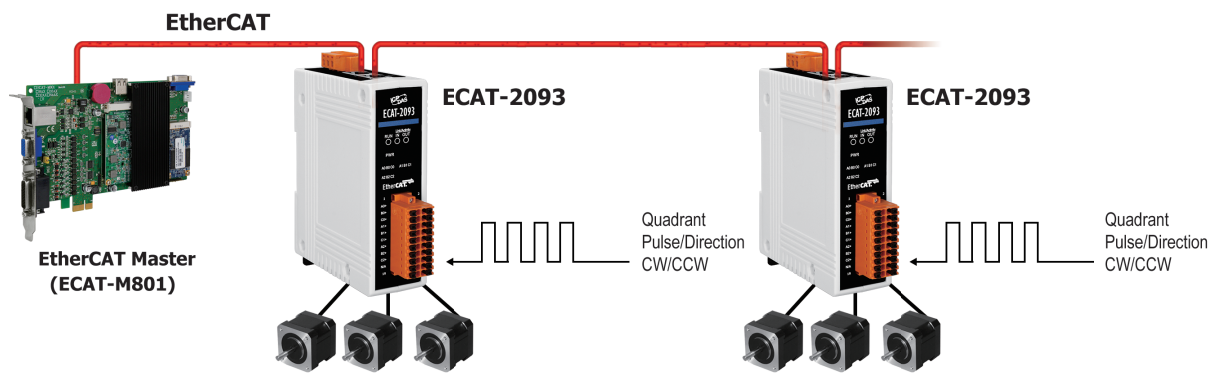

Ordering Information

ECAT-2093 CR	EtherCAT three-channel incremental encoder counter (RoHS)
--------------	---