DeviceNet Slave Device

CAN-2057D

Application User's Manual

Warranty

Without contrived damage, all products manufactured by ICP DAS are warranted in one year from the date of delivery to customers.

Warning

ICP DAS revises the manual at any time without notice. However, no responsibility is taken by ICP DAS unless infringement act imperils to patents of the third parties.

Copyright

Copyright © 2010 is reserved by ICP DAS.

Trademark

The brand name ICP DAS as a trademark is registered, and can be used by other authorized companies.

Contents

1	Introduction.....	3
1.1	Overview.....	3
1.2	Hardware Specifications	4
1.3	Features.....	5
1.4	Application	5
2	Hardware	6
2.1	Structure.....	6
2.2	Node ID & Baud Rate Rotary Switch	7
2.3	LED Description.....	8
2.4	PIN Assignment	10
2.5	Wire Connection	11
3	DeviceNet Profile Area	12
3.1	DeviceNet Statement of Compliance.....	12
3.2	Identity Object (Class ID: 0x01)	13
3.3	Connection Object (Class ID:0x05)	14
3.4	Assembly Object (Class ID: 0x04)	15
3.5	Application Object1 (Class ID: 0x64).....	17
4	Application	19
	Appendix A: Dimension.....	21

1 Introduction

1.1 Overview

DeviceNet is one kind of the network protocols based on the CAN bus and mainly used for the embedded network of the machine control, such as industrial machine control , aircraft engines monitoring, factory automation, medical equipments control, remote data acquisition, environmental monitoring, and packaging machines control, etc.

The CAN-2057D follows DeviceNet specification Volume I/II, Release 2.0. User can access the digital output status and set the configuration via DeviceNet EDS file. The CAN-2057D has 16 Digital output channels with Open Collector output type and can be used to develop powerful and cost effective digital control system. By owing to the DeviceNet masters of ICP DAS, you can quickly build a DeviceNet network to approach your requirements.



1.2 Hardware Specifications

Digital Output:

- Output Channels: 16 (Sink)
- Output Type: Open Collector.
- Max Load Current: 100 mA per channel.
- Load Voltage: +5 V_{DC} ~ +30 V_{DC}.
- Intra-module Isolation, Field to Logic: 3750 Vrms.
- ESD Protection: 4 kV Contact for each channel.

Others:

- DeviceNet Status: 3 LEDs for PWR / NET / MOD.
- Terminal Resister: 1 LED as terminator resister indicators
- DO LED: 16 LEDs as digital output indicators.
- Power Requirement: +10 ~ +30 V_{DC}, 1.0 W.
- Operating Temperature: -25 ~ 75 °C.
- Storage Temperature: -30 ~ 80 °C.
- Humidity: 10 to 90% RH, Non-condensing.
- Dimensions: 32.3 mm x 99 mm x 77.5 mm (W x L x H) [Detail](#).

1.3 Features

- DeviceNet general I/O slave devices.
- Comply with DeviceNet specification Volume I, Release 2.0 & Volume II, Release 2.0, Errata 5
- Group 2 Only Server (non UCMM-capable)
- Support Predefined Master/Slave Connection Set
- Connection supported:
 - 1 connection for Explicit Messaging
 - 1 connection for Polled I/O
 - 1 connection for Bit-Strobe I/O connection
- Support DeviceNet heartbeat and shutdown messages
- Provide EDS file for standard DeviceNet master interface.
- NET, MOD and PWR DeviceNet status LED indicators

1.4 Application

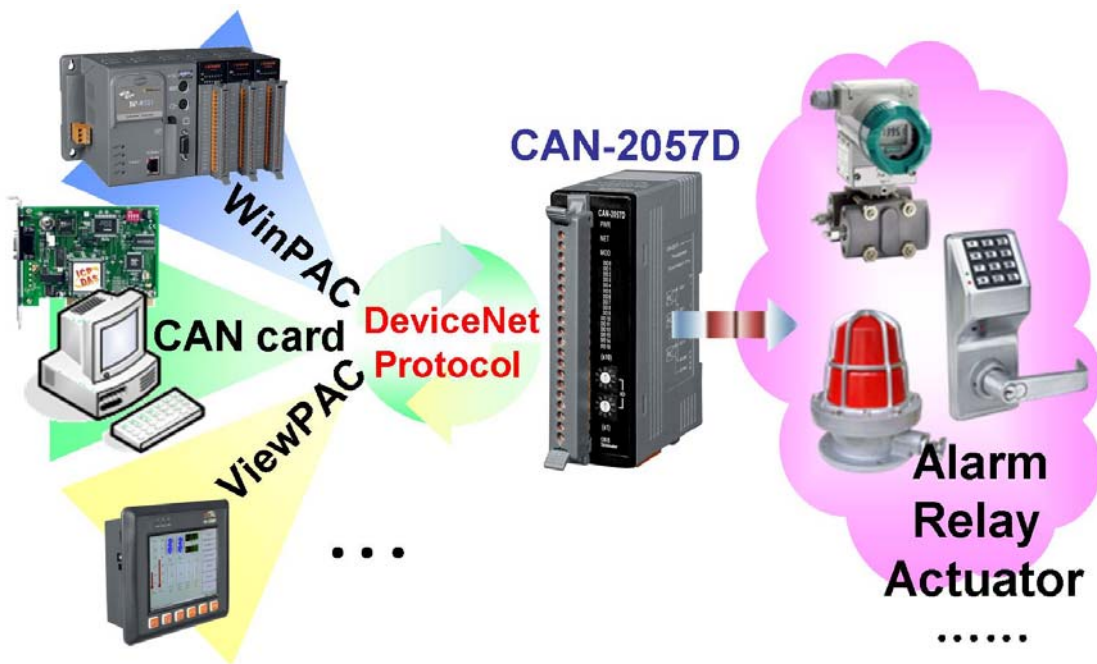

2 Hardware

2.1 Structure

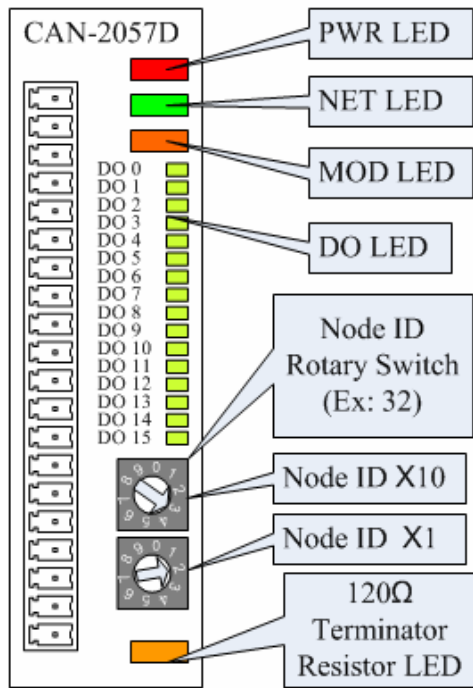

(Top View)

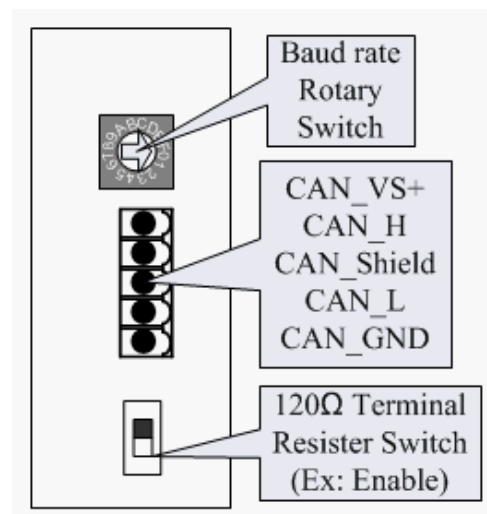

(Bottom View)

2.2 Node ID & Baud Rate Rotary Switch

The rotary switches of node ID configure the node ID of CAN-2057D module. These two switches are for the tens digit and the units digit of the node ID. The node ID value of this demo picture is 32.

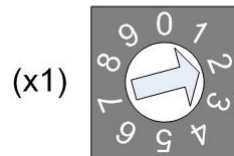
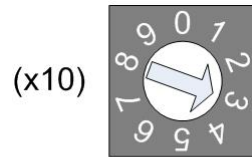

The rotary switch for baud rate handles the CAN baud rate of CAN-2057D module. The relationship between the rotary switch value and the practical baud rate is presented in the following table.



Baud rate rotary switch

Rotary Switch Value	Baud rate (kbps)
0	125
1	250
2	500

2.3 LED Description

PWR LED

The CAN-2057D needs the power of 10 ~ 30 V_{DC}. Under a normal connection, a good power supply and a correct voltage selection, as the unit is turned on, the LED will light up in red.

NET LED

The NET LED indicates the current status of the DeviceNet communication link.

condition	status	indicates
Init Off	Off line	Device is not online
Off	Connection timeout	I/O connection timeout
Flashing	On line	Device is on line, but not communicating
Init solid	Link failed	(Critical) Device has detected an error that has rendered it incapable of communicating on the link; for example, detected a duplicate node address or network configuration error
Solid	On line, communicating	Device is online and communicating

MOD LED

This LED provides the devices status. It indicates whether or not the device is operating properly.

condition	status	indicates
Off	Normal	
Solid	Critical fault	Device has unrecoverable fault.
Flashing	Non_critical fault	Device has recoverable fault to recover. If users want to fix the problem, reconfiguring device's MAC ID or resetting device may work.

Terminal Resistor LED

When enable the 120Ω terminator resistor, the LED will turn on.

DO LED

If the DO LED turns on, it means that the corresponding DO channel sends an ON voltage-level digital signal.

2.4 PIN Assignment

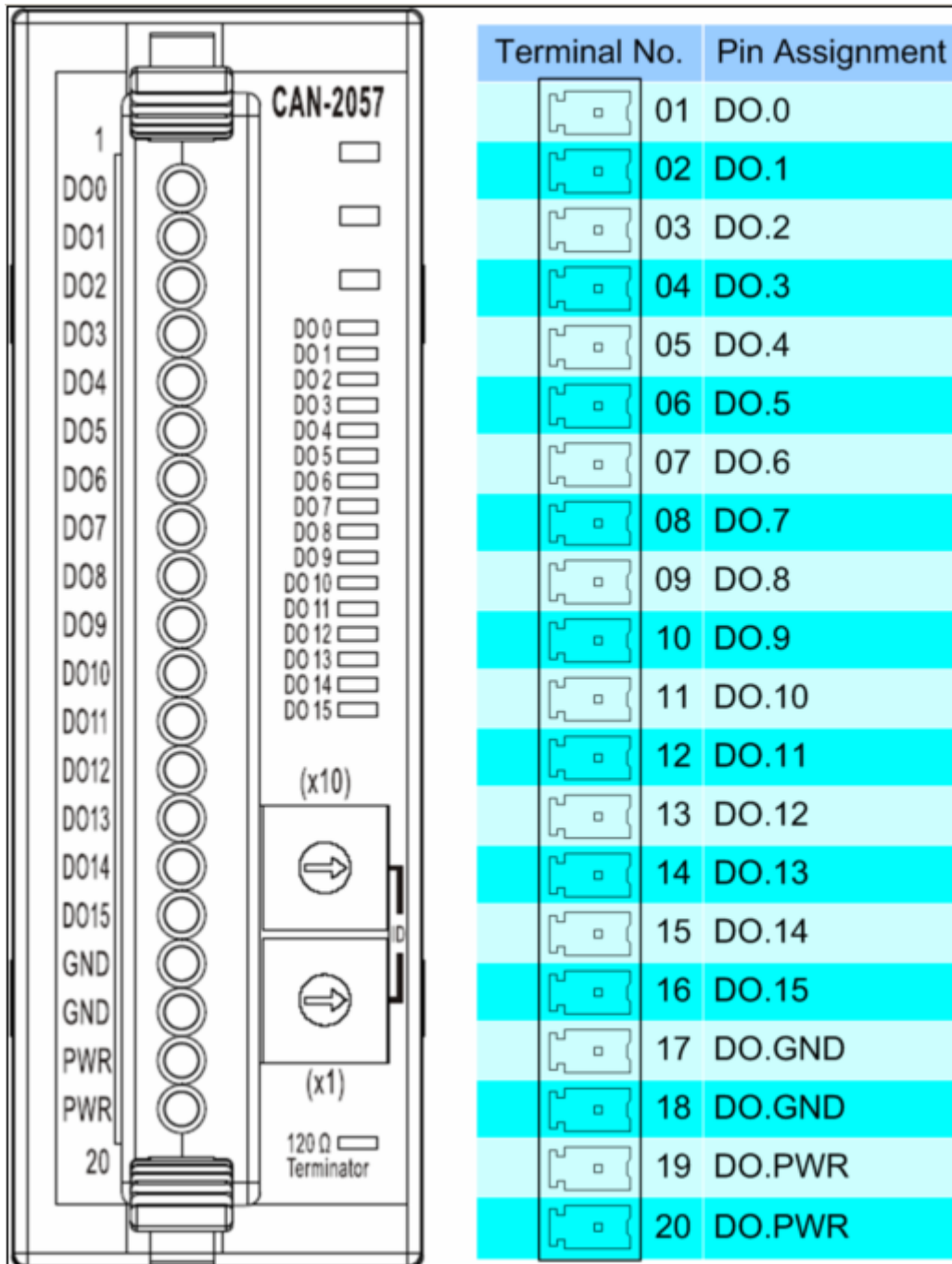

2.5 Wire Connection

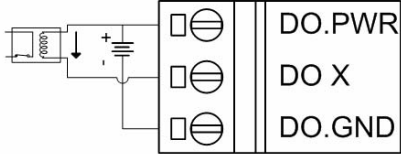
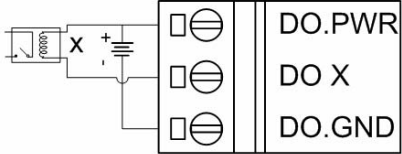
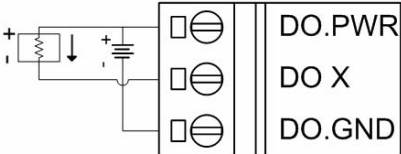
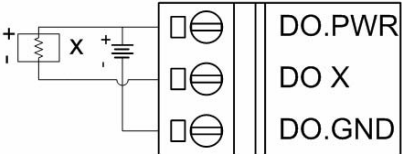
Output Type	ON State LED ON Readback as 1	OFF State LED OFF Readback as 0
Drive Relay	Relay On	Relay Off
		
Resistance Load		
		

3 DeviceNet Profile Area

This section documents the detailed functions for each object class that is implemented in the CAN-2057D DeviceNet network.

3.1 DeviceNet Statement of Compliance

General Device Data

Device Information	Description
Version Description of DeviceNet Specification	Volume I, Release 2.0 & Volume II, Release 2.0
Vendor Name	ICP DAS
Device Profile Name	CAN-2057D
Production Revision	1.1

DeviceNet Physical Conformance Data

Item	Description
LED Support	Yes
MAC ID Setting	Switch (0 ~ 63)
Default MAC ID	1
Communication Baud Rate Setting	Switch (125, 250, 500 kbps)
Default Baud Rate	125 kbps
Predefined Master/Slave Connection Set	Group 2 Only Server

3.2 Identity Object (Class ID: 0x01)

This object provides the identification of and general information about the device.

Class Attribute (Instance ID=0)

Attribute ID	Attribute name	Data Type	Method	Value
0x01	Revision	UINT	Get	0001
0x02	Max Instance	UINT	Get	1

Class Service

Service Code	Service name	Support
0x0E	Get_Attribute_Single	Yes

Instance Attribute (Instance ID=1)

Attribute ID	Description	Method	DeviceNet Data Type	Value
1	Vendor	Get	UINT	803
2	Product type	Get	UINT	0x00
3	Product code	Get	UINT	0x200
4	Major. Minor of firmware version	Get	Struct of USINT USINT	1.1
5	Status	Get	WORD	-
6	Serial number	Get	UDINT	1
7	Product name	Get	Short_String	CAN-2057D
10	Heartbeat Interval	Get/Set	USINT	0(default)

Instance Service

Service Code	Service name	Support
0x0E	Get_Attribute_Single	Yes
0x10	Set_Attribute_Single	Yes
0x05	Reset	Yes

Note: Use the Instance Service 0x05 will reboot the device.

3.3 Connection Object (Class ID:0x05)

This section presents the externally visible characteristics of the Connection Objects associated with the Predefined Master/Slave Connection Set within slave devices.

The default IO connection path is as follow.

Connection Path	Class ID	Instance ID	Attribute ID
Poll Produced	0x04	0x64	0x03
Poll Consumed	0x04	0x64	0x03
Bit Strobe Produced	0x04	0x64	0x03
Bit Strobe Consumed	0x04	0x64	0x03

Connection Instance ID	Description
1	References the Explicit Messaging Connection into the Server
2	References the Poll I/O Connection
3	References the Bit–Strobe I/O Connection

3.4 Assembly Object (Class ID: 0x04)

The Assembly Object binds attributes of multiple objects, which allows data to or from each object to be sent or received over a single connection. Assembly objects can be used to bind input data or output data. The terms of "input" and "output" are defined from the network's point of view. An input will produce data on the network and an output will consume data from the network.

Class attribute (Instance ID=0)

Attribute ID	Attribute name	Data Type	Method	Value
0x01	Revision	UINT	Get	1
0x02	Max Instance	UINT	Get	0x01

Class service

Service Code	Service name	Support
0x0E	Get_Attribute_Single	Yes

Instance ID

Instance ID	OUTPUT	INPUT
0x64	Set DO value	Get DO value

Contents of Each Assembly Object Instance

Instance ID	Description	Type	Method	Default Value
0x64	Channel 0 ~ 15 DO value	UINT	Get/Set	0x0000

Parameter description of Assembly Object Instance

Instance ID	Data Range	Parameter Description
0x64	0x0000 ~ 0xFFFF	Bit 0 => channel 0 DO value Bit 1 => channel 1 DO value ... Bit 15 => channel 15 DO value

Note: x is channel number of module

Instance attribute (Instance ID=0x64)

Attribute ID	Description	Method	DeviceNet Data Type	Value
0x03	Data	Get/Set	OUTPUT/ INPUT	Dependent on instance ID

Instance service

Service Code	Service name	Support
0x0E	Get_Attribute_Single	Yes
0x10	Set_Attribute_Single	Yes

3.5 Application Object1 (Class ID: 0x64)

Application objects are the interfaces between an application and the DeviceNet Layer. The attributes of application Objects contain the data for the application, which are accessed and exchanged via DeviceNet. DeviceNet accesses application data by invoking read and write functions. These functions need to be provided by an Application Object. DeviceNet provides Get_Attribute_Single and Set_Attribute_Single to read and write CAN-2057D module.

Application Object1 defines digital output channels configuration.

Class attribute (Instance ID=0)

Attribute ID	Attribute name	Data Type	Method	Value
0x01	Revision	UINT	Get	1
0x02	Max Instance	UINT	Get	0x05

Class service

Service Code	Service name	Support
0x0E	Get_Attribute_Single	Yes

Instance attribute (Instance ID=0x01)

Attribute ID	Description	Method	Data Type	Default Value
0x01	DO value	Get/Set	UINT	0x0000
0x02	DO power on value	Get/Set	UINT	0x0000
0x03	DO safe value mask	Get/Set	UINT	0x0000
0x04	DO safe value	Get/Set	UINT	0x0000
0x05	Save all Configuration to EEPROM	Set	USINT	-

Parameter description of Application Object1 attributes

Attribute ID	Data Range	Parameter Description
0x01	0x0000 ~ 0xFFFF	Bit 0 => channel 0 DO value Bit 1 => channel 1 DO value ... Bit 15 => channel 15 DO value
0x02	0x0000 ~ 0xFFFF	Bit 0 => channel 0 DO power on value Bit 1 => channel 1 DO power on value ... Bit 15 => channel 15 DO power on value
0x03	0x0000 ~ 0xFFFF	Bit 0 => channel 0 DO safe value mask Bit 1 => channel 1 DO safe value mask ... Bit 15 => channel 15 DO safe value mask Bit value=1 => apply safe value setting Bit value=0 => apply DO output value
0x04	0x0000 ~ 0xFFFF	Bit 0 => channel 0 DO safe value Bit 1 => channel 1 DO safe value ... Bit 15 => channel 15 DO safe value
0x05	0x01: Use default configuration 0x02: Save all Configuration to EEPROM	0x01: After restarting the device, configuration will become factory setting. 0x02: Save all channels configuration into EEPROM

Instance service

Service Code	Service name	Support
0x0E	Get_Attribute_Single	Yes
0x10	Set_Attribute_Single	Yes

4 Application

Application Object1 (Class ID:0x64) lists all the parameters of the module. Each Instance ID is corresponding to the different channels. By using “Set/Get Attribute Single” service, user can read/write the parameters of each channel.

Example1:

Set DO output value.

(Class ID: 0x64, Instance ID: 0x01, Attribute ID 0x01).

If the node ID of the CAN-2057D is 1, and the master (ID: 0x0A) has completed “Explicit” connection with the device. By setting the value of Attribute ID 0x01 to 0x00F0, you can set the DO4, DO5, DO6, and DO7 to turn ON and others to turn OFF.

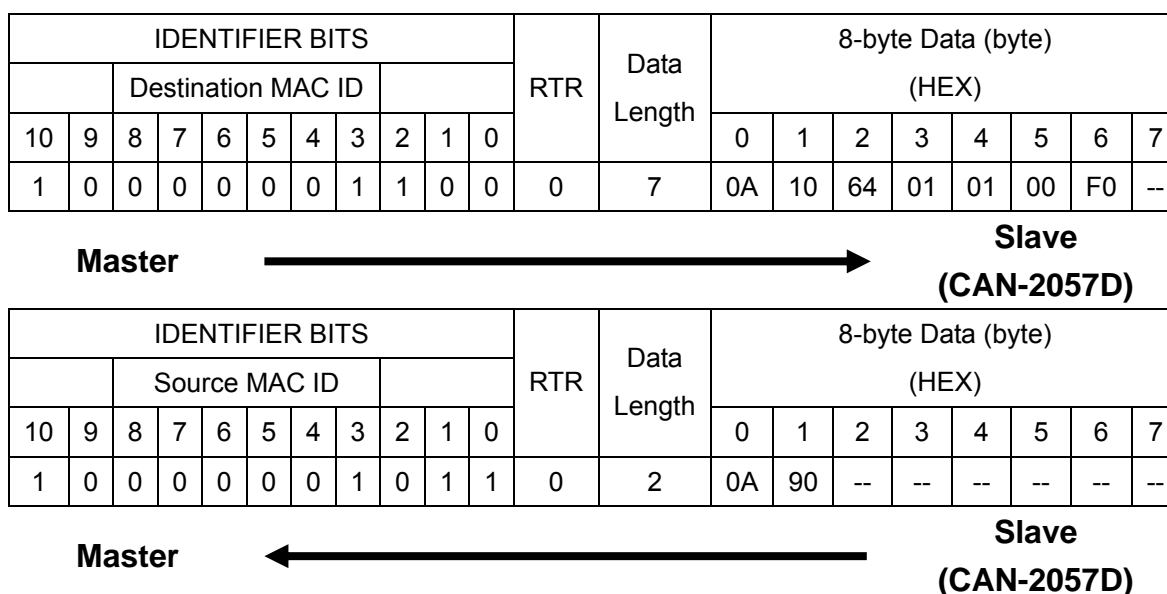

Set the value 0x00F0 to the Application Object1 with Instance ID 0x01 and Attribute ID 0x01. After sending the “Set Attribute Single”, the slave device will response 0x90 to mean that the setting is OK. Then the DO4, DO5, DO6, and DO7 will be turned ON and others are turned OFF.

Via changing the Attribute ID of the Application Object, user can set other parameters of this device.

Example2:

Get DO data (Class ID: 0x64, Instance ID: 0x01, Attribute ID 0x01).

If the node ID of the CAN-2057D is 1, and the master (id: 0x0A) has completed “Explicit” connection with the device. By getting the value of the object with attribute ID 0x01, you can get the channel 0 ~ 15 of the DO data.

IDENTIFIER BITS											RTR	Data Length	8-byte Data (byte) (HEX)							
Destination MAC ID																				
10	9	8	7	6	5	4	3	2	1	0			0	1	2	3	4	5	6	7
1	0	0	0	0	0	0	1	1	0	0	0	5	0A	0E	64	01	01	--	--	--

Master → **Slave (CAN-2057D)**

IDENTIFIER BITS											RTR	Data Length	8-byte Data (byte) (HEX)							
Source MAC ID																				
10	9	8	7	6	5	4	3	2	1	0			0	1	2	3	4	5	6	7
1	0	0	0	0	0	0	1	0	1	1	0	4	0A	8E	00	0F	--	--	--	--

Master ← **Slave (CAN-2057D)**

Get the value of Application Object1 with Instance ID 0x01 and Attribute ID 0x01. After sending the “Get Attribute Single”, the slave device response the DO data (0x000F) at byte 2 and byte 3. The value 0x000F means that the status of DO3, DO2, DO1 and DO0 are turned on and others are turned off.

Via changing the Attribute ID of the Application Object1, user can get other parameters of this device.

The attribute 0x02 of Application Object1 can control the DO power on value of each channel. After setting this attribute, the DO channels will output DO power on value when booting up.

Attribute 0x03 and 0x04 of Application Object1 are used for safe value configuration when “Explicit Message Timeout” error occurs. When setting the channel selection value of the Attribute ID 0x03 to “1”, the safe value of Channel 0 will be active. If the value is set to 0x4, it means that the safe value of the channel 2 is active. Afterwards, you can configure the output safe value of this channel by setting the value of Attribute ID 0x04. When setting the Attribute ID 0x03 to “0x1” and Attribute ID 0x04 to “0x1”, the channel 0 will turn ON while the error occurs.

Appendix A: Dimension

