

PETL/tET/tPET DIO Series User Manual

Ethernet I/O Modules

Ver. 1.8, Jan. 2014

WARRANTY

All products manufactured by ICP DAS are warranted against defective materials for a period of one year from the date of delivery to the original purchaser.

WARNING

ICP DAS assumes no liability for damages consequent to the use of this product. ICP DAS reserves the right to change this manual at any time without notice. The information furnished by ICP DAS is believed to be accurate and reliable. However, no responsibility is assumed by ICP DAS for its use, nor for any infringements of patents or other rights of third parties resulting from its use.

COPYRIGHT

Copyright © 2013 by ICP DAS. All rights are reserved.

TRADEMARK

Names are used for identification only and may be registered trademarks of their respective companies.

CONTACT Us

If you have any questions, please feel free to contact us via email at:

service@icpdas.com, service.icpdas@gmail.com



SUPPORT

This manual relates to the following modules:

PETL-7060

tET-P6, tPET-P6

tET-PD6, tPET-PD6

tET-C4, tPET-C4

tET-A4, tPET-A4

tET-P2C2, tPET-P2C2

tET-P2A2, tPET-P2A2

tET-P2POR2, tPET-P2POR2,

tET-PD2POR2, tPET-PD2POR2

tET-P2R2, tPET-P2R2

tET-PD2R1, tPET-PD2R1

TABLE OF CONTENTS

1. INTRODUCTION	4
1.1 PRODUCT INFORMATION.....	5
1.1.1 <i>Ethernet IO Module Series</i>	5
1.1.2 <i>Selection Guide</i>	7
1.1.3 <i>Comparison of PETL/tET/tPET Module</i>	8
1.2 FEATURES	10
2. HARDWARE INFORMATION	13
2.1 FRONT AND BACK PANEL.....	13
2.2 SPECIFICATIONS.....	18
2.2.1 <i>System Specifications</i>	18
2.2.2 <i>I/O Specifications</i>	19
2.3 PIN ASSIGNMENTS.....	24
2.3.1 <i>tET-P6/tPET-P6/tET-PD6/tPET-PD6</i>	24
2.3.2 <i>tET-C4/tPET-C4/tET-A4/tPET-A4</i>	25
2.3.3 <i>tET-P2POR2/tPET-P2POR2/tET-P2R2/tPET-P2R2</i>	26
2.3.4 <i>tET-PD2POR2/tPET-PD2POR2</i>	27
2.3.5 <i>tET-PD2R1/tPET-PD2R1</i>	28
2.3.6 <i>tET-P2C2/tPET-P2C2/tET-P2A2/tPET-P2A2</i>	29
2.3.7 <i>PETL-7060</i>	30
2.4 WIRING CONNECTIONS.....	31
2.4.1 <i>Input Wiring</i>	31
2.4.2 <i>Output Wiring</i>	32
2.5 DIMENSIONS	34
3. GETTING STARTED	36
3.1 MOUNTING THE MODULE.....	36
3.2 CONFIGURING THE BOOT MODE	38
3.3 CONNECTING TO A NETWORK, A PC AND A POWER SUPPLY	39
3.4 USING THE ESEARCH UTILITY TO ASSIGN A NEW IP	40
4. WEB CONFIGURATION	42
4.1 HOME PAGE	44
4.2 NETWORK SETTINGS	45
4.2.1 <i>Network and Miscellaneous Settings</i>	45
4.2.2 <i>IP Address Configuration</i>	46
4.2.3 <i>General Configuration Settings</i>	49
4.2.4 <i>Restoring Factory Defaults</i>	50
4.3 I/O SETTINGS.....	52
4.3.1 <i>DO Control</i>	52

- 4.3.2 DI/DO Configuration..... 53
- 4.4 PWM..... 55
 - 4.4.1 PWM Configuration..... 55
- 4.5 PAIR CONNECTION..... 56
 - 4.5.1 Settings..... 56
- 4.6 FILTER 58
 - 4.6.1 Filter Settings 58
- 4.7 CHANGE PASSWORD 59
- 4.8 LOGOUT 59
- 5. I/O PAIR CONNECTION APPLICATIONS60**
 - 5.1 ONE MODULE POLLING THE REMOTE DI/DO (1-TO-1, POLLING MODE) 60
 - 5.2 TWO MODULES PUSHING THE LOCAL DI TO EACH OTHER (1-TO-1, PUSH MODE) 64
 - 5.3 SEVERAL MODULES POLLING THE REMOTE DI (M-TO-1, POLLING MODE) 66
 - 5.4 SEVERAL MODULES PUSHING THE LOCAL DI (M-TO-1, PUSH MODE).....70
- 6. MODBUS INFORMATION 74**
 - 6.1 WHAT IS MODBUS TCP/IP?..... 75
 - 6.2 MODBUS MESSAGE STRUCTURE..... 75
 - 6.2.1 01 (0x01) Read the Status of the Coils (Readback DOs) 78
 - 6.2.2 02 (0x02) Read the Status of the Input (Read DIs)..... 80
 - 6.2.3 03 (0x03) Read the Holding Registers (Readback AOs)..... 82
 - 6.2.4 04 (0x04) Read the Input Registers (Read AIs)..... 84
 - 6.2.5 05 (0x05) Force a Single Coil (Write DO)..... 86
 - 6.2.6 06 (0x06) Preset a Single Register (Write AO)..... 88
 - 6.2.7 15 (0x0F) Force Multiple Coils (Write DOs)..... 90
 - 6.2.8 16 (0x10) Preset Multiple Registers (Write AOs)..... 92
 - 6.3 MODBUS REGISTER TABLE..... 95
 - 6.3.1 Common Functions..... 95
 - 6.3.2 Specific Functions 97
- 7. RELATED TOOLS101**
 - 7.1 LABVIEW..... 101
 - 7.2 OPC SERVER..... 101
 - 7.3 SCADA..... 102
- FAQ104**
 - A. HOW DO I PREVENT IE FROM SHOWING A BLANK PAGE WHEN CONFIGURING THE PETL/TET/TPET SERIES MODULE..... 104
 - B. HOW TO UPDATE THE FIRMWARE VIA ETHERNET..... 106
 - C. WHY ISN'T MY HOST COMPUTER ABLE TO PING OR SEARCH FOR THE PETL/TET/TPET SERIES MODULE?.....107

1. Introduction

The tET/tPET and PETL-7060 series of devices are IP-based Ethernet I/O monitoring and control modules that provide networking ability and a variety of digital I/O functions. The modules can be remotely controlled through a 10/100 M Ethernet network using the Modbus TCP/UDP protocol. Modbus has become a de facto standard communications, and is now the most commonly available means of connecting industrial electronic devices. This makes the tET/tPET and PETL-7060 series perfect for integration with HMI, SCADA, PLC and other software systems.

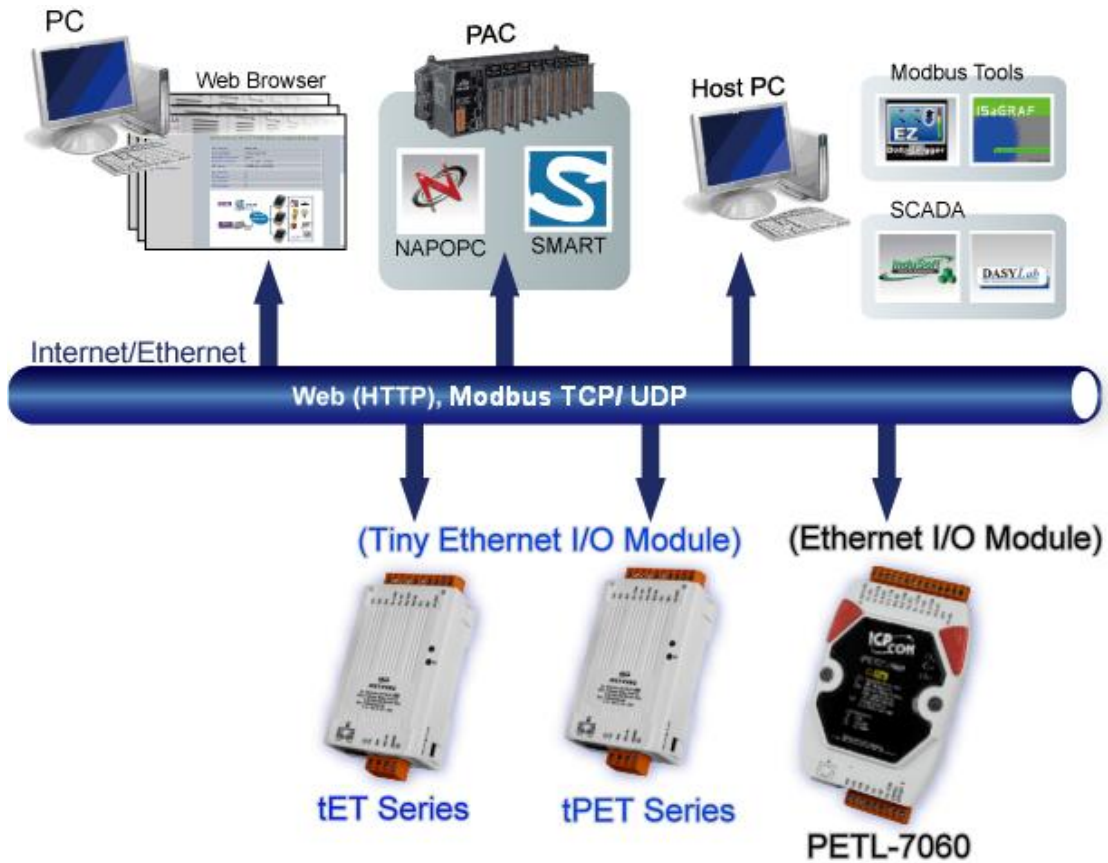

1.1 Product Information

1.1.1 Ethernet IO Module Series

The tET/tPET and PETL-7060 series of Ethernet I/O modules support a range of I/O formats, such as photo-isolated digital input, relay contact, PhotoMOS relay, and open-collector output, etc.

The table below provides a description of each model.

DC Digital Input	
tET-P6	Tiny Ethernet module with 6-channel digital input (Wet Contact)
tET-PD6	Tiny Ethernet module with 6-channel digital input (Dry Contact)
tPET-P6	Tiny Ethernet module with PoE and 6-channel digital input (Wet Contact)
tPET-PD6	Tiny Ethernet module with PoE and 6-channel digital input (Dry Contact)

DC Digital Output	
tET-C4	Tiny Ethernet module with 4-channel digital output (NPN, Sink)
tET-A4	Tiny Ethernet module with 4-channel digital output (PNP, Source)
tPET-C4	Tiny Ethernet module with PoE and 4-channel digital output (NPN, Sink)
tPET-A4	Tiny Ethernet module with PoE and 4-channel digital output (PNP, Source)

DC Digital Input and Output	
tET-P2C2	Tiny Ethernet module with 2-channel digital input and 2-channel digital output (NPN, Sink)
tET-P2A2	Tiny Ethernet module with 2-channel digital input and 2-channel digital output (PNP, Source)
tPET-P2C2	Tiny Ethernet module with PoE, 2-channel digital input and 2-channel digital output (NPN, Sink)
tPET-P2A2	Tiny Ethernet module with PoE, 2-channel digital input and 2-channel digital output (PNP, Source)

Power Relay Output	
tET-P2R2	Tiny Ethernet module with 2-channel digital input (Wet Contact) and 2-channel Form A power relay output
tET-PD2R1	Tiny Ethernet module with 2-channel digital input (Dry Contact) and 1-channel Form A power relay output
tPET-P2R2	Tiny Ethernet module with PoE, 2-channel digital input (Wet Contact) and 2-channel Form A power relay output
tPET-PD2R1	Tiny Ethernet module with PoE, 2-channel digital input (Dry Contact) and 1-channel Form A power relay output
PETL-7060	Ethernet module with 6-channel digital input (Wet Contact) and 6-channel Form A power relay output

PhotoMOS Relay Output	
tET-P2POR2	Tiny Ethernet module with 2-channel digital input (Wet Contact) and 2-channel Form A PhotoMOS relay output
tET-PD2POR2	Tiny Ethernet module with 2-channel digital input (Dry Contact) and 2-channel Form A PhotoMOS relay output
tPET-P2POR2	Tiny Ethernet module with PoE, 2-channel digital input (Wet Contact) and 2-channel Form A PhotoMOS relay output
tPET-PD2POR2	Tiny Ethernet module with PoE, 2-channel digital input (Dry Contact) and 2-channel Form A PhotoMOS relay output

1.1.2 Selection Guide

Model		I/O Specifications			Ethernet 10/100 M	Modbus TCP
Ethernet	PoE	D/I (Type)	D/O (Type)	Isolation		
tET-P6	tPET-P6	6-channel (Wet Contact)	-	Yes	Yes	Yes
tET-PD6	tPET-PD6	6-channel (Dry Contact)	-			
tET-C4	tPET-C4	-	4-channel (Sink)			
tET-A4	tPET-A4	-	4-channel (Source)			
tET-P2C2	tPET-P2C2	2-channel (Wet Contact)	2-channel (Sink)			
tET-P2A2	tPET-P2A2	2-channel (Wet Contact)	2-channel (Source)			
tET-P2POR2	tPET-P2POR2	2-channel (Wet Contact)	2-channel Form A PhotoMos Relay			
tET-PD2POR2	tPET-PD2POR2	2-channel (Dry Contact)	2-channel Form A PhotoMos Relay			
tET-P2R2	tPET-P2R2	2-channel (Wet Contact)	2-channel Form A Relay			
tET-PD2R1	tPET-PD2R1	2-channel (Dry Contact)	1-channel Form A Relay			
-	PETL-7060	6-channel (Wet Contact)	6-channel Form A Relay			

1.1.3 Comparison of PETL/tET/tPET Module

The tPET and PETL-7060 series features true IEEE 802.3af-compliant (classification, Class 1) Power over Ethernet (PoE) functions. Now, not only can data be carried through an Ethernet cable, but power can also be provided. This feature makes installation of tPET series modules a straightforward task. Imagine no more unnecessary wires with only an Ethernet cable required in order to take care of everything in the field.

The tET/tPET and PETL-7060 series also features a built-in web server that allows basic configuration, I/O monitoring and I/O control to be performed by simply using a web browser meaning that remote control of your modules is as easy as surfing the Internet. In addition, tET/tPET and PETL-7060 series modules support the Modbus TCP/UDP protocols, ensuring perfect integration with SCADA software.

Industrial PoE Solutions

When using PoE devices such as the tPET series, you can incorporate the ICP DAS “PoE” switch, the “NS-205PSE”, as the power source. The NS-205PSE automatically detects any connected devices, whether they are PoE devices or not. This mechanism ensures that the NS-205PSE will function simultaneously with both PoE and non-PoE devices.

Note that when acting as a power source for a PoE device, the NS-205PSE requires a power input ranging from +46 V_{DC} to +55 V_{DC}.



More Information

All tET series modules can only be powered using a +12 V_{DC} to +48 V_{DC} power supply connected through a removable terminal block.

In contrast, tPET and PETL-7060 series modules offer two methods of supplying power. The first is through the Ethernet via a PoE switch; the second is through a removable terminal block via an external power source. The external power supply should be in the range of +12 V_{DC} to 48 V_{DC}. The reason for including the second method is to provide a redundant power input feature. tPET and PETL-7060 series modules also indicate an LED that indicates whether the power is being supplied by the PoE switch or not.

	tPET	PETL-7060	PET-7000
CPU	32-bit ARM		80186
Ethernet	10/100 M, PoE		
Modbus TCP/UDP	Yes		
Web Configuration	Yes		
Web HMI	Simplified		Yes
Multi-client	Yes (Max. Connections: 5)		Yes (Max. Connections: 12)
IP Filter	Yes (white list)		
Latched DI	Yes		
DI as Counter	32-bit, 3.5 kHz		32-bit, 500 Hz
Frequency Measurement	Yes (3.5 kHz Max.)		-
I/O Pair-connection	Yes (Poll/Push Mode)		Yes (Poll Mode)
PWM	Yes (100 Hz Max.)		-
Dual-Watchdog	Yes (CPU, Host)		Yes (Module, Host)
ESD Protection	+/- 4 kV		
Surge Protection	-	+/- 0.5 kV	
Form Factor	Tiny Size		Palm Size
Remarks	Cost-effective		-
Note: tET = tPET without PoE functionality.			

1.2 Features

Built-in Web Server

Each tET/tPET/PETL series module contains a built-in web server that allows users to easily configure, monitor and control the module from a remote location using a web browser.

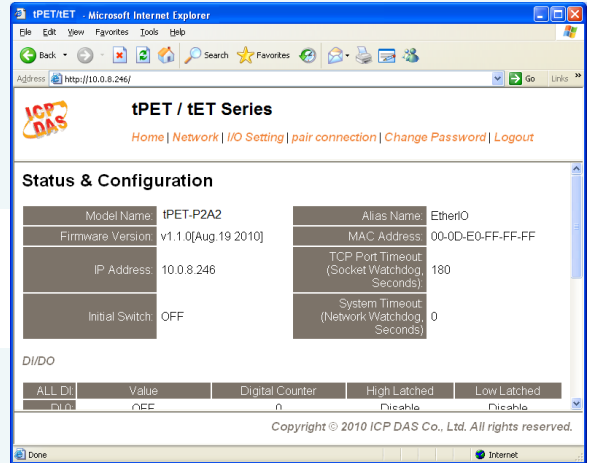

Modbus Protocol

The Modbus TCP/UDP slave function on the Ethernet port can be used to provide data to remote SCADA software.

All-in-one Module

A variety of I/O components are available on multiple channels in a single module, which provides the most cost effective I/O usage and enhances the performance of I/O operations.

Automatic MDI/MDI-X Detection for Plug-and-Play

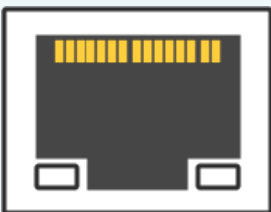

The RJ-45 port supports automatic sensing of MDI/MDI-x switching that can automatically detect the type of connection being used by the Ethernet device without requiring special straight or crossover cables.

Built-in Multi-Function I/O

1. All **Digital Output** modules provide:

- A **Power-on Value** (On boot up, the digital output value is set as the Power-on value)
- A **Safe Value** (If Modbus TCP communication is lost for a certain period, the digital output value will be set as the user-defined safe value)
- A **PWM Function**: The digital output channels on PETL/tET/tPET series include a PWM (pulse generation) function that can be used to set different frequencies (50 or 100 Hz Max.) and duty cycles for each digital output channel. In addition, the two digital output channels can work either independently or simultaneously. The term “High Duty Cycle” describes the duration of 'on' time in proportion to the regular interval or 'period' of time. Similarly, the term “Low Duty Cycle” corresponds to the duration of the 'off' time. Consequently, it is not necessary to keep switching from ON to OFF from remote a controller. In this way, the tET/tPET/PETL series module reduces the complexity required for the control system and enhances timing accuracy.

2. All **Digital Input** modules provide:

- **Digital input channels that can also be used as 32-bit high speed (3.5 kHz) counters.**
- **High/Low Latched Status Commands**: The modules provide commands to read the status of any digital input channels that are latched high or latched low. The following is an example that shows the usefulness of the latched digital input. If we wish to read a key stroke from a key switch connected to the digital input channel of a module, the input signal of the key stroke is a pulse signal as shown in the figure.

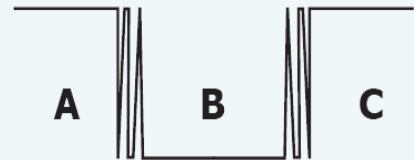

If we just use the read digital input status command to read the signal and we cannot send the command during the B period due to some reasons, then we will lose the key stroke information. However, with the read latched digital input command, we can still get the key stroke information even we are not able to send command in B period.

- **Frequency Measurement**: tET/tPET/PETL series modules also provide a frequency measurement function that retrieves the digital input counter value at specific times and calculates the frequency. Rather than polling via a remote host, the tET/tPET/PETL series modules can determine the frequency directly, reducing the communication delay caused by two ends and also improves the accuracy of the frequency measurement. In order to applying for more applications, this module provides 3 scan modes and 4 moving average methods for user to select the best way in their applications.

Built-in Dual Watchdog

The Dual Watchdog consists of a CPU Watchdog (for hardware functions) and a Host Watchdog (for software functions).

The **CPU Watchdog** will automatically reset it-self if the built-in firmware encounters an abnormal situation.

If there is no communication between the module and the host (PC or PLC) for a specified period of time (i.e., the Watchdog timeout), the **Host Watchdog** will set the digital output based on a predefined safe-value.



I/O Pair-Connection

The I/O Pair-connection function is used to create a digital input to digital output pair through the Ethernet. Once the configuration is complete, the PETL/tET/tPET series modules can continuously poll the status of a remote digital input device using the Modbus TCP protocol, and then write to the local digital output channels in the background.

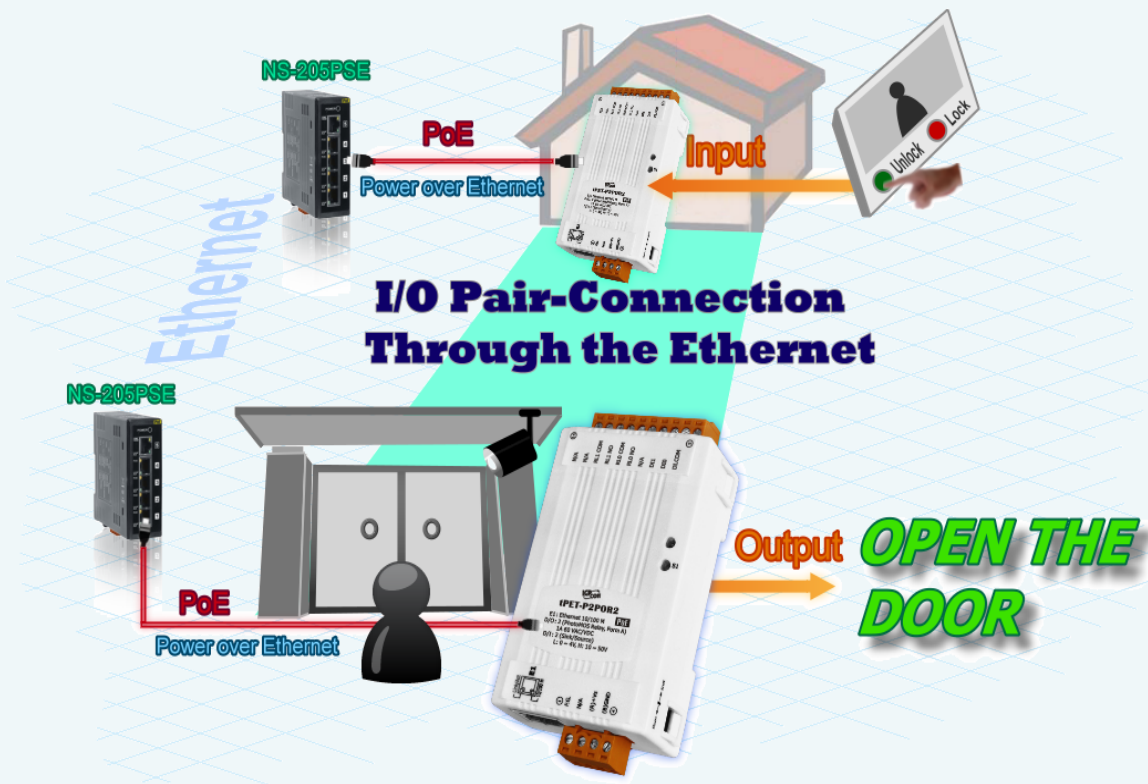

2. Hardware Information

2.1 Front and Back Panel

The following is a brief overview and description of the components included in PETL/tET/tPET series modules.

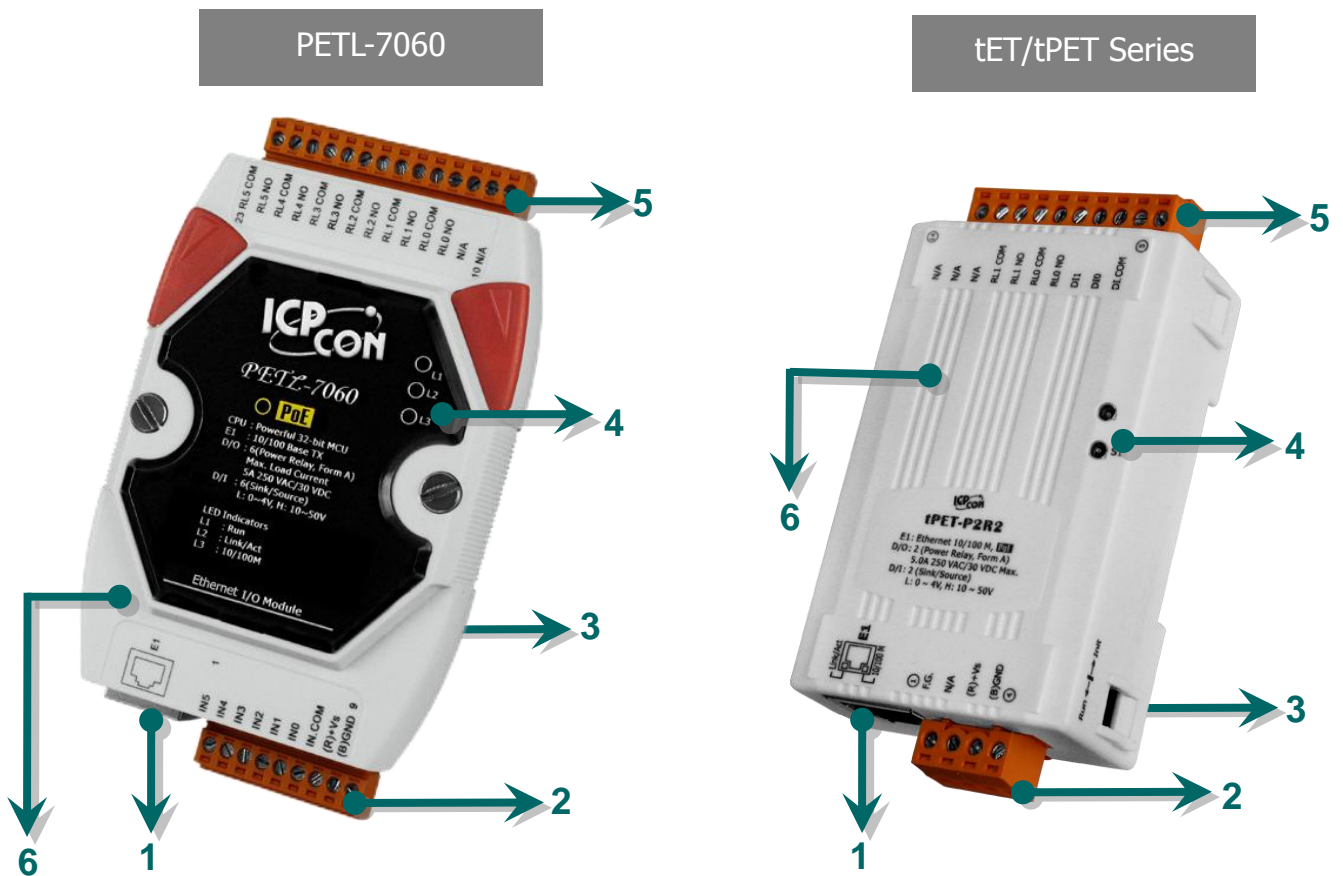

1	Ethernet Port	4	System LED Indicator
2	J1 Connector	5	J2 Connector
3	Operating Mode Switch	6	Robust insulated and fire retardant case

1. Ethernet Port

The PETL/tET/tPET series module are equipped with an RJ-45 jack that is used as the 10/100 Base-TX Ethernet port and features networking capability. When an Ethernet link is detected and an Ethernet packet is received, the **Link/Act LED (Green)** indicator and the **10/100 M LED (Yellow)** indicator will be illuminated.

! The Ethernet port supports PoE (Power-over-Ethernet) functions for PETL/tPET series modules only.

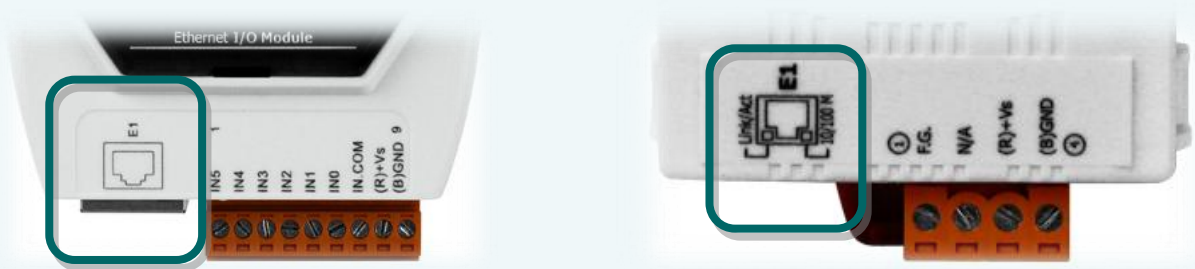

2. J1 Connector

The type of J1 connector used depends on the type of PETL/tET/tPET series module. For more detailed information regarding the pin assignments for the J1 Connector, please refer to [Section 2.3. “Pin Assignments”](#).

■ DC Power Input:

The definition for “(R)+Vs” and “(B)GND” for use as the power supply applies to all types of PETL/tET/tPET series module.

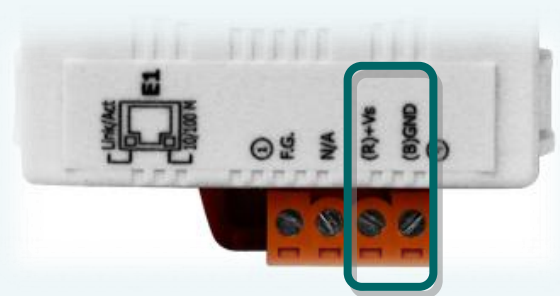

Module	Pin	Name	Function
PETL-7060	8	(R)+Vs	+12 to +48 V _{DC} Power Input
	9	(B)GND	Ground Connection
tET/tPET	3	(R)+Vs	+12 to +48 V _{DC} Power Input
	4	(B)GND	Ground Connection

■ **Frame Ground:**

Electronic circuits are constantly vulnerable to Electrostatic Discharge (ESD), which becomes worse in a continental climate area. PETL/tET/tPET series module feature a new design for the frame ground, which provides a path that bypasses ESD, resulting in an enhanced ESD protection capability and ensuring that the module is more reliable.

✓ **The frame ground (F.G.) of the tET/tPET series, as follows:**

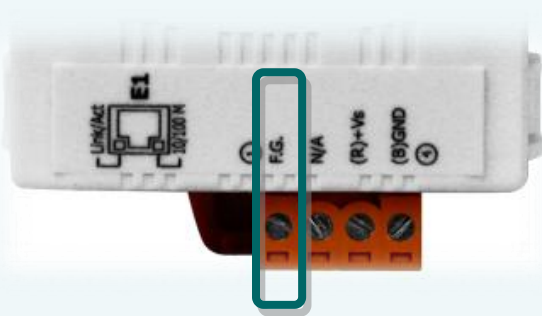

Module	Pin	Name	Function
tET/tPET	1	F.G.	Frame Ground

✓ **The frame ground (F.G.) of the PETL-7060, as follows:**

The PETL-7060 controller has a metallic board attached to the back of the plastic casing as indicated by point 1 in the figure.

When mounted to the DIN-Rail, connect the DIN-Rail to the earth ground because the DIN-Rail is in contact with the upper frame ground as shown in the figure, point 2.

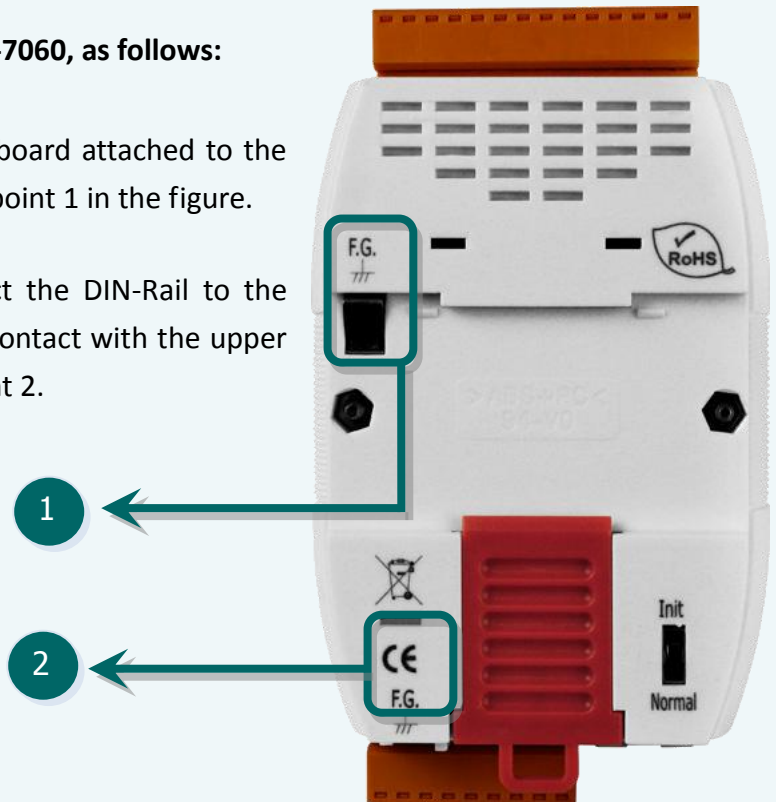

3. Operating Mode Switch

- **Init mode:** Uses factory settings and allows the firmware to be updated.
- **Run/Normal mode:** Uses customer settings.

 **Note: The module must be rebooted after changing operating.**

The operating mode switch for PETL/tET/tPET series modules is set to the **Run/Normal** position by default. When updating the PETL/tET/tPET firmware, the switch should be moved from the **Run/Normal** position to the **Init** position. The switch must then be returned to the **Run/Normal** position once the update is complete.

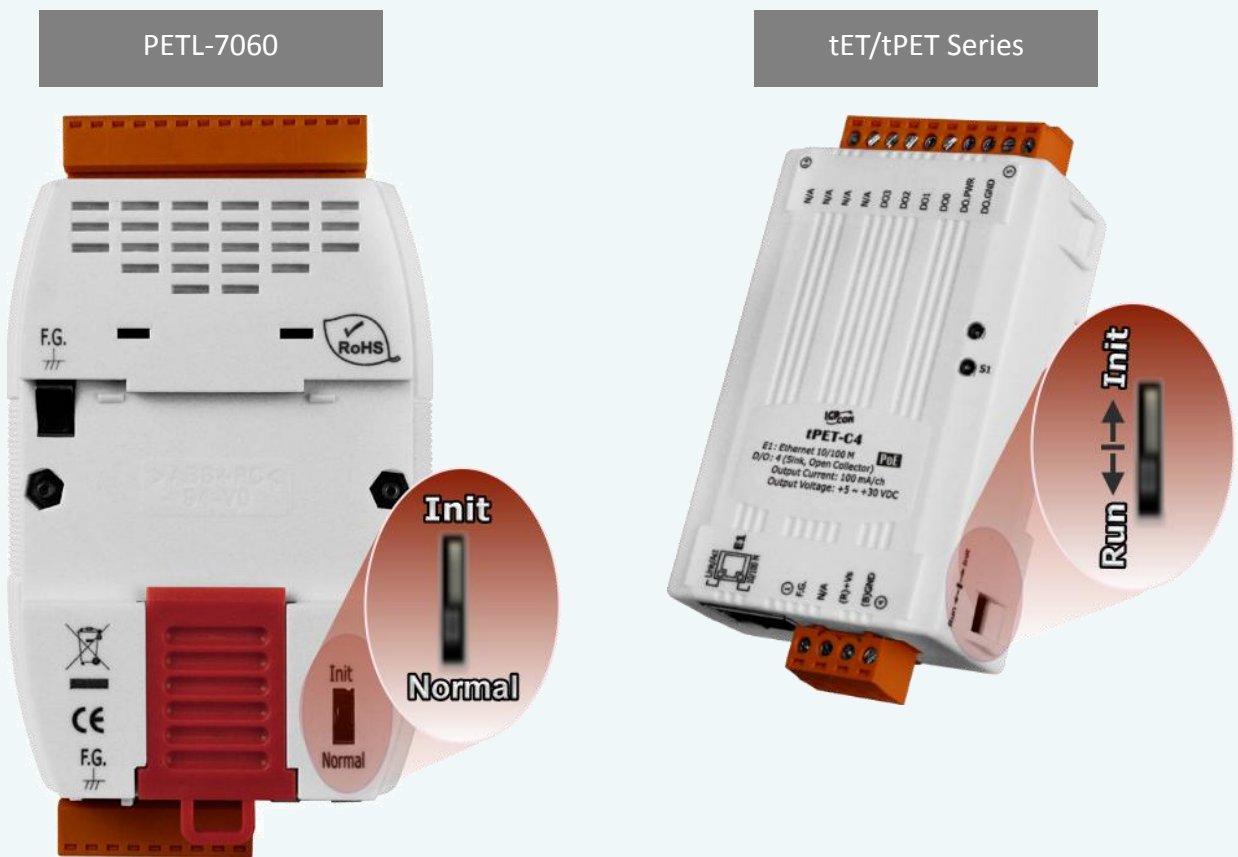

4. System LED Indicator

Once power is supplied to the PETL/tET/tPET series module, the LED indicator will be illuminated as follows:

tET/tPET Series	
Function	System LED Behavior
Running Firmware	ON (Red)
Network Ready	Flashing once every 3 seconds (Red)
PoE (for tPET only)	ON (Green)

PETL-7060		
Name	Function	System LED Behavior
L1	Running Firmware	ON (Red)
L2	Link/ACT (Red)	ON: Ethernet link detected OFF: No Ethernet link detected Flashing: Ethernet packet received
L3	10/100M (Yellow)	OFF: the speed is 10 Mbps ON: the speed is 100 Mbps
PoE	Supply power	ON (Green)



The PoE LED (Green) indicator is only applicable to PETL/tPET series modules.

5. J2 Connector

The J2 connector depends on the type of the PETL/tET/tPET series module. For more detailed information regarding the pin assignments for the J2 Connector, refer to [Section 2.3. “Pin Assignments”](#).

2.2 Specifications

2.2.1 System Specifications

Modules	tET Series	tPET Series	PETL-7060
System			
CPU	32-bit MCU		
Dual Watchdog	Yes		
Communication			
Ethernet Port	10/100 Base-TX, 8-Pin RJ-45 x1, (Auto-negotiating, Auto-MDI/MDIX, LED Indicator)		
	-	PoE (IEEE 802.3af, Class 1)	
LED Display			
PoE Indicator	-	S1 (Green)	PoE (Green)
System Indicator	S1 (Red)		L1 (Red)
Link/Act Indicator	E1(Green)		L2 (Red)
10/100 M Indicator	E1 (Yellow)		L3 (Yellow)
Mechanical			
Dimensions (W x H x D)(mm)	52 x 27 x 98		123 x 72 x 35
Installation	DIN-Rail mounting		DIN-Rail or Wall mounting
Environment			
Operating Temperature	-25 °C ~ +75 °C		
Storage Temperature	-30 °C ~ +80 °C		
Humidity	10 ~ 90 % RH, non-condensing		
Power Requirements			
Power Input	-	PoE: IEEE 802.3af, Class 1	
	Terminal Block: +12 ~ 48 V _{DC} (non-regulated)		
Power Consumption	0.04 A @ 24 V _{DC} for tET-P2R2	0.03 A @ 48 V _{DC} for tPET-P2R2	0.05 A @ 48 V _{DC}

2.2.2 I/O Specifications

2.2.2.1 tET-P6/tPET-P6/tET-PD6/tPET-PD6

Models		tET-P6 tPET-P6	tET-PD6 tPET-PD6
Digital Input			
Input Channels		6	
Input Type (Device)		Wet Contact (Sink, Source)	Dry Contact (Source)
On Voltage Level		+10 V _{DC} ~ +50 V _{DC}	Close to GND
Off Voltage Level		+4 V _{DC} max.	Open
Input Impedance		10 kΩ	-
Counters	Max. Count	4,294,967,285 (32 bits)	
	Min. Pulse Width	0.15 ms	
Frequency Measurement		3.5 kHz (without filter)	
Overvoltage Protection		+70 V _{DC}	-
Isolation		3750 V _{rms}	
Effective Distance		-	500 M Max.

2.2.2.2 tET-C4/tPET-C4/tET-A4/tPET-A4

Models		tET-C4 tPET-C4	tET-A4 tPET-A4
Digital Output			
Output Channels		4	
Output Type (Module)		Sink, Open Collector (NPN)	Source, Open Collector (PNP)
Output Voltage		+5 V _{DC} ~ +30 V _{DC}	+10 V _{DC} ~ +40 V _{DC}
Max. Load Current		100 mA/channel	650 mA/channel
PWM		100 Hz Max. (The High/Low duty cycle range = 5 ~ 65,535 ms)	
Over-Voltage		+60 V _{DC}	+48 V _{DC}
Short Circuit Protection		-	Yes
Output Isolation		3750 V _{rms}	

2.2.2.3 tET-P2C2/tPET-P2C2/tET-P2A2/tPET-P2A2

Models	tET-P2C2 tPET-P2C2	tET-P2A2 tPET-P2A2
Digital Input		
Input Channels	2	
Input Type (Device)	Wet Contact (Sink, Source)	
On Voltage Level	+10 V _{DC} ~ +50 V _{DC}	
Off Voltage Level	+4 V _{DC} Max.	
Input Impedance	10 kΩ	
Counters	Max. Count: 4,294,967,285 (32 bits)	
	Min. Pulse Width: 0.15 ms	
Frequency Measurement	3.5 kHz (without filter)	
Overtoltage Protection	+70 V _{DC}	
Isolation	3750 V _{rms}	
Digital Output		
Output Channels	2	
Output Type (Module)	Sink, Open Collector (NPN)	Source, Open Collector (PNP)
Output Voltage	+5 V _{DC} ~ +30 V _{DC}	+10 V _{DC} ~ +40 V _{DC}
Max. Load Current	100 mA/channel	650 mA/channel
PWM	100 Hz Max. (The High/Low duty cycle Range = 5 ~ 65,535 ms)	
Over-Voltage	+60 V _{DC}	+48 V _{DC}
Short Circuit Protection	-	Yes
Output Isolation	3750 V _{rms}	

2.2.2.4 tET-P2POR2/tPET-P2POR2/tET-PD2POR2/tPET-PD2POR2

Models		tET-P2POR2 tPET-P2POR2	tET-PD2POR2 tPET-PD2POR2
Digital Input			
Input Channels		2	
Input Type (Device)		Wet Contact (Sink, Source)	Dry Contact (Source)
On Voltage Level		+10 V _{DC} ~ +50 V _{DC}	Close to GND
Off Voltage Level		+4 V _{DC} Max.	Open
Input Impedance		10 kΩ	-
Counters	Max. Count	4,294,967,285 (32 bits)	
	Min. Pulse Width	0.15 ms	
Frequency Measurement		3.5 kHz (without filter)	
Overvoltage Protection		+70 V _{DC}	-
Isolation		3750 V _{rms}	
Effective Distance		-	500 M Max.
Relay Output			
Output Channels		2	
Output Type (Module)		PhotoMOS Relay, Form A	
Load Voltage		60 V _{DC} / V _{AC}	
Load Current	60 V/1.0 A (Operating Temperature -25°C ~ -40°C)		
	60 V/0.8 A (Operating Temperature +40°C ~ +60°C)		
	60 V/0.7 A (Operating Temperature +60°C ~ +75°C)		
PWM		100 Hz max. (The High/Low duty cycle range = 5 ~ 65,535 ms)	
Turn ON Time		1.3 ms (Typical)	
Turn Off Time		0.1 ms (Typical)	
Output Isolation		3000 V _{rms}	



Because of the characteristics of the relay functions, it is recommended that the PWM on t(P)ET-P(D)2POR2/ t(P)ET-P2R2/ t(P)ET-PD2R1/ PETL-7060 series modules (i.e., modules with relay functions) is not used for extended periods of time.

2.2.2.5 tET-P2R2/tPET-P2R2/tET-PD2R1/tPET-PD2R1

Models		tET-P2R2 tPET-P2R2	tET-PD2R1 tPET-PD2R1
Digital Input			
Input Channels		2	
Input Type (Device)		Wet Contact (Sink, Source)	Dry Contact (Source)
On Voltage Level		+10 V _{DC} ~ +50 V _{DC}	Close to GND
Off Voltage Level		+4 V _{DC} Max.	Open
Input Impedance		10 kΩ	-
Counters	Max. Count	4,294,967,285 (32 bits)	
	Min. Pulse Width	0.15 ms	
Frequency Measurement		3.5 kHz (without filter)	
Overvoltage Protection		+70 V _{DC}	-
Isolation		3750 V _{rms}	
Effective Distance		-	500 M Max.
Relay Output			
Output Channels		2	1
Output Type (Module)		Power Relay, Form A (SPST N.O.)	
Output Voltage Range		250 V _{AC} /30 V _{DC}	
Max. Load Current		5.0 A/channel	
Operate Time		6 ms	
Release Time		3 ms	
PWM		50 Hz max. (The High/Low duty cycle range = 10 ~ 65,535 ms)	
Electrical Life (Resistive load)	VED	5 A 250 V _{AC} 30,000 ops (10 ops/minute) at 75 °C	
		5 A 30 V _{DC} 70,000 ops (10 ops/minute) at 75 °C	
	UL	5 A 250 V _{AC} /30 V _{DC} 6,000 ops	
		3 A 250 V _{AC} /30 V _{DC} 100,000 ops	
Mechanical Life		20,000,000 ops. At no load (300 ops./ minute)	
Output Isolation		3000 V _{rms}	



Because of the characteristics of the relay functions, it is recommended that the PWM on t(P)ET-P(D)2POR2/ t(P)ET-P2R2/ t(P)ET-PD2R1/ PETL-7060 series modules (i.e., modules with relay functions) is not used for extended periods of time.

2.2.2.6 PETL-7060

Models		PETL-7060
Digital Input		
Input Channels		6
Input Type (Device)		Wet Contact (Sink, Source)
On Voltage Level		+10 V _{DC} ~ +50 V _{DC}
Off Voltage Level		+4 V _{DC} Max.
Input Impedance		10 kΩ
Counters	Max. Count	4,294,967,285 (32 bits)
	Min. Pulse Width	0.15 ms
Frequency Measurement		3.5 kHz (without filter)
Overvoltage Protection		+70 V _{DC}
Isolation		3750 V _{rms}
Relay Output		
Output Channels		6
Output Type (Module)		Power Relay, Form A (SPST N.O.)
Output Voltage Range		250 V _{AC} /30 V _{DC}
Max. Load Current		5.0 A/channel
Operate Time		6 ms
Release Time		3 ms
PWM		50 Hz max. (The High/Low duty cycle range = 10 ~ 65,535 ms)
Electrical Life (Resistive load)	VED	5 A 250 V _{AC} 30,000 ops (10 ops/minute) at 75 °C
		5 A 30 V _{DC} 70,000 ops (10 ops/minute) at 75 °C
	UL	5 A 250 V _{AC} /30 V _{DC} 6,000 ops
		3 A 250 V _{AC} /30 V _{DC} 100,000 ops
Mechanical Life		20,000,000 ops. At no load (300 ops./ minute)
Output Isolation		3000 V _{rms}



Because of the characteristics of the relay functions, it is recommended that the PWM on t(P)ET-P(D)2POR2/ t(P)ET-P2R2/ t(P)ET-PD2R1/ PETL-7060 series modules (i.e., modules with relay functions) is not used for extended periods of time.

2.3 Pin Assignments

2.3.1 tET-P6/tPET-P6/tET-PD6/tPET-PD6

- : I/O Address Mapping
- : Counter Address Mapping

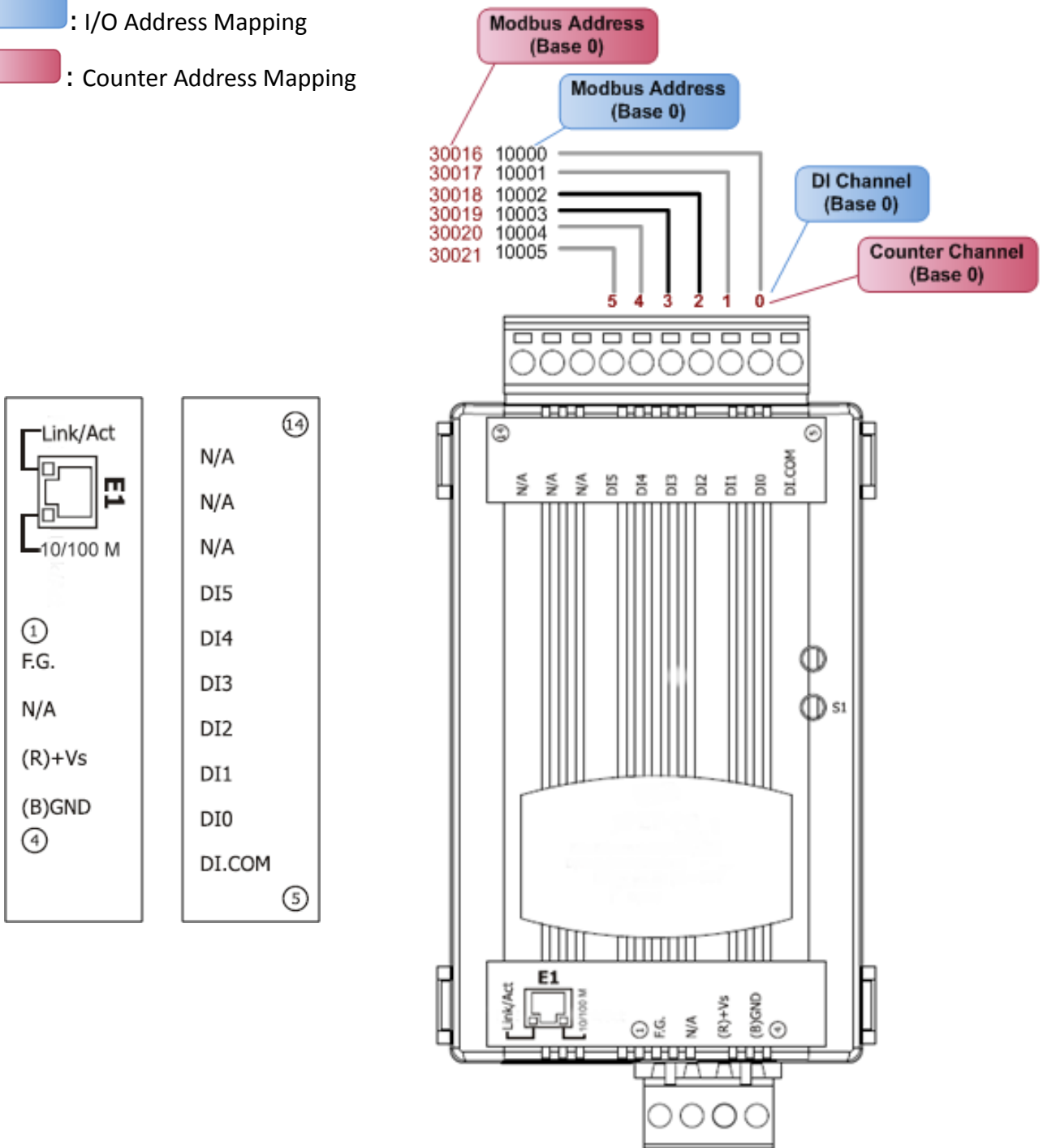

2.3.2 tET-C4/tPET-C4/tET-A4/tPET-A4

: I/O Address Mapping

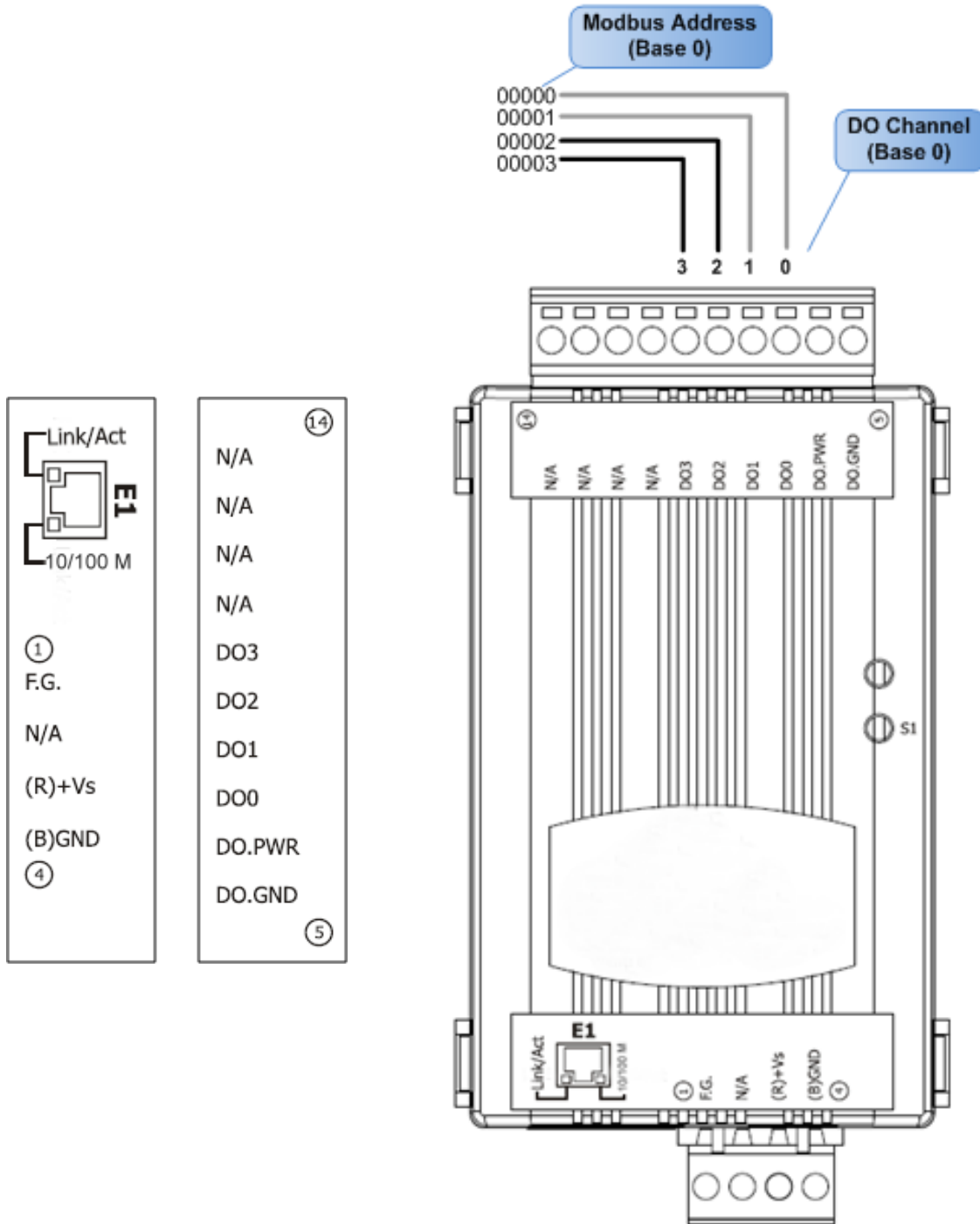

2.3.3 tET-P2POR2/tPET-P2POR2/tET-P2R2/tPET-P2R2

- : I/O Address Mapping
- : Counter Address Mapping

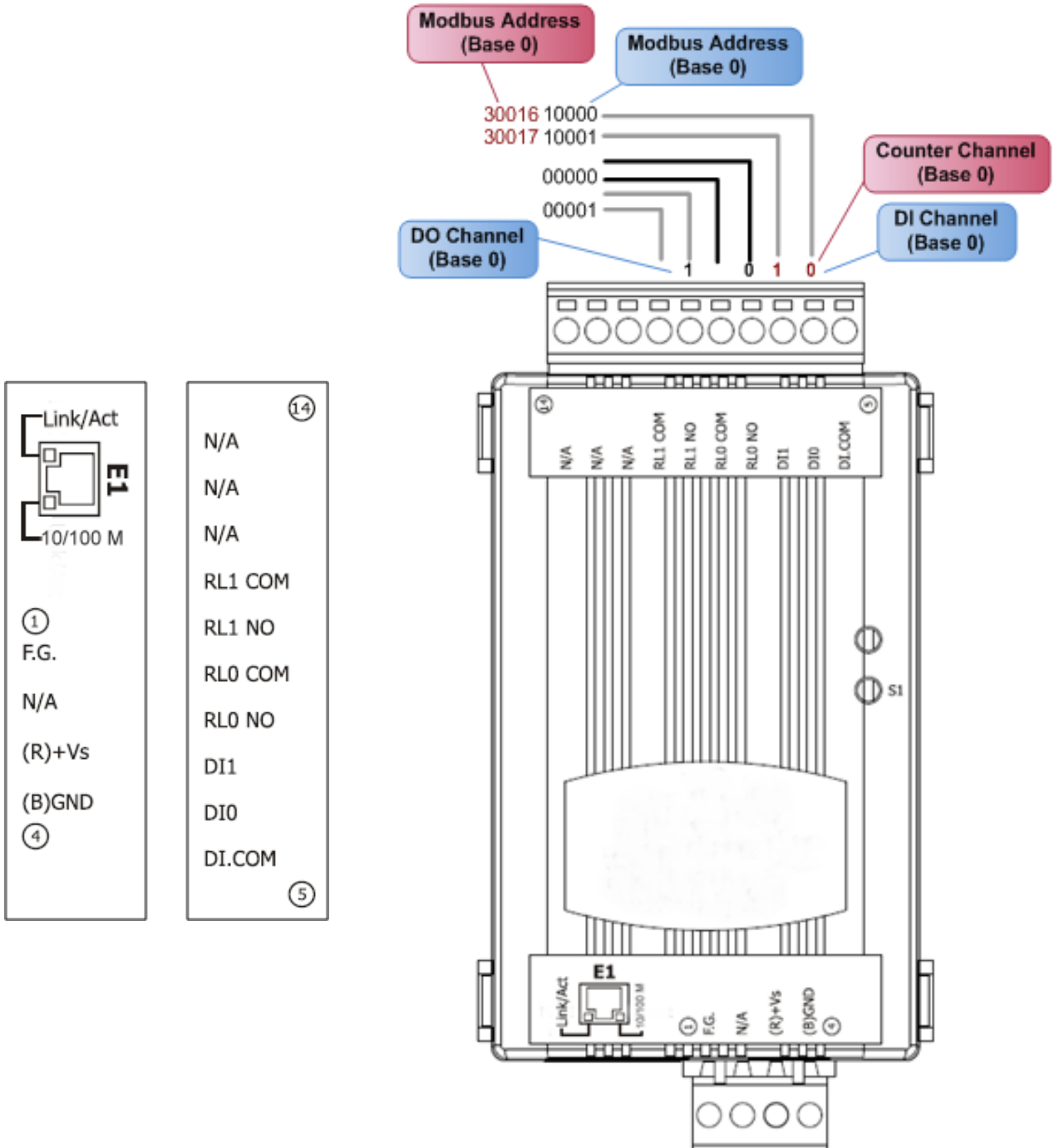

2.3.4 tET-PD2POR2/tPET-PD2POR2

: I/O Address Mapping

: Counter Address Mapping

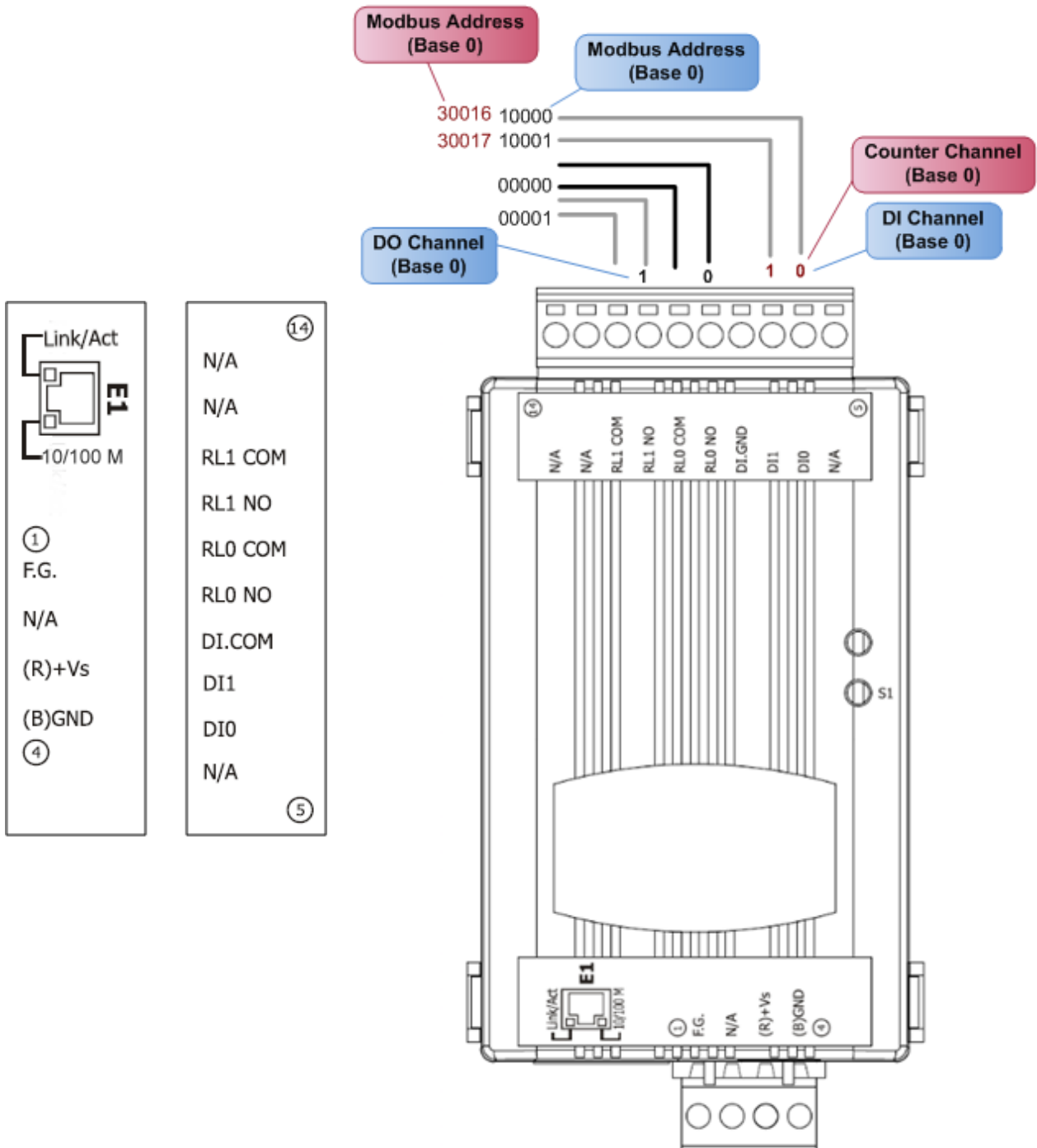

2.3.5 tET-PD2R1/tPET-PD2R1

 : I/O Address Mapping

 : Counter Address Mapping

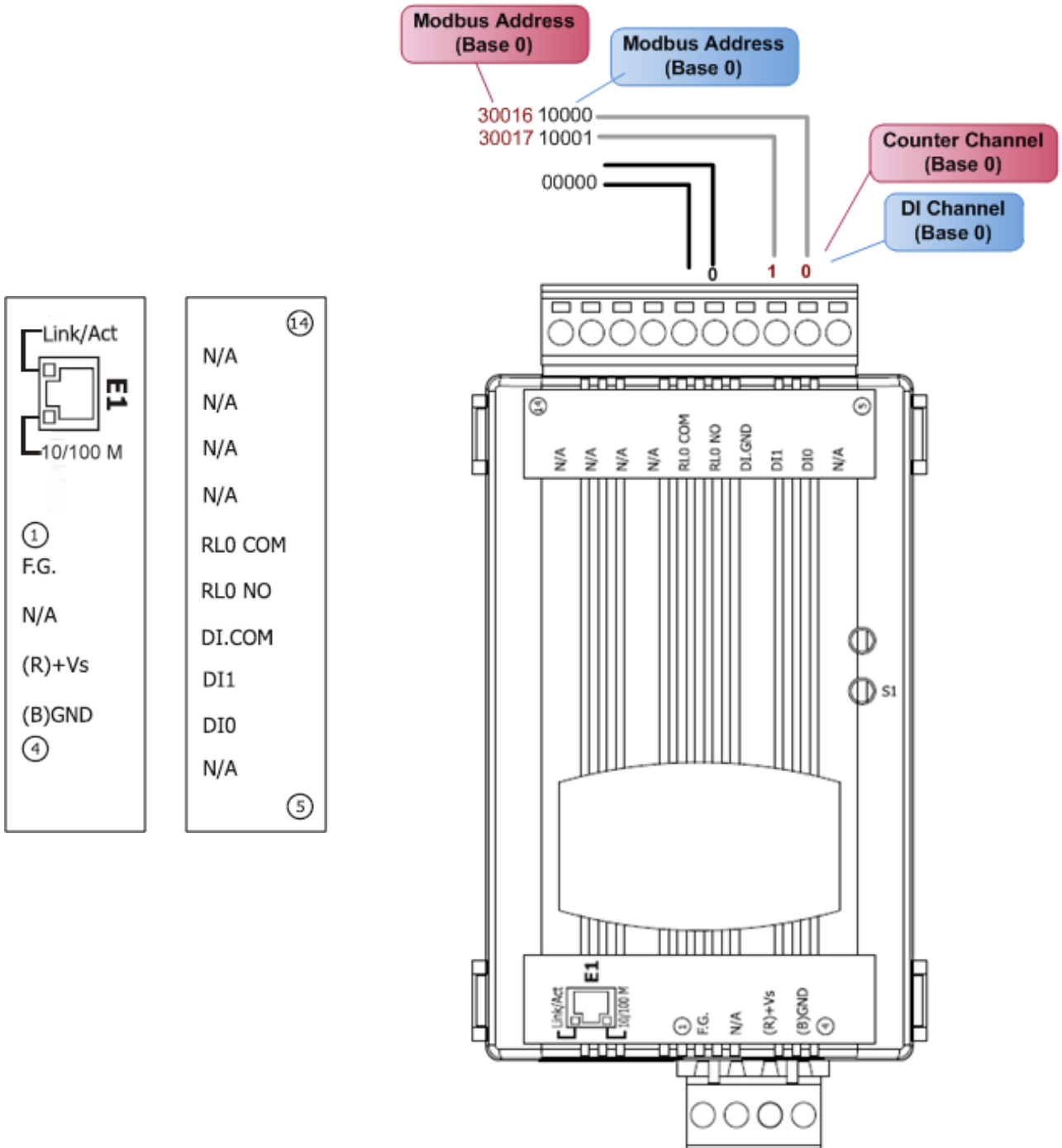

2.3.6 tET-P2C2/tPET-P2C2/tET-P2A2/tPET-P2A2

- : I/O Address Mapping
- : Counter Address Mapping

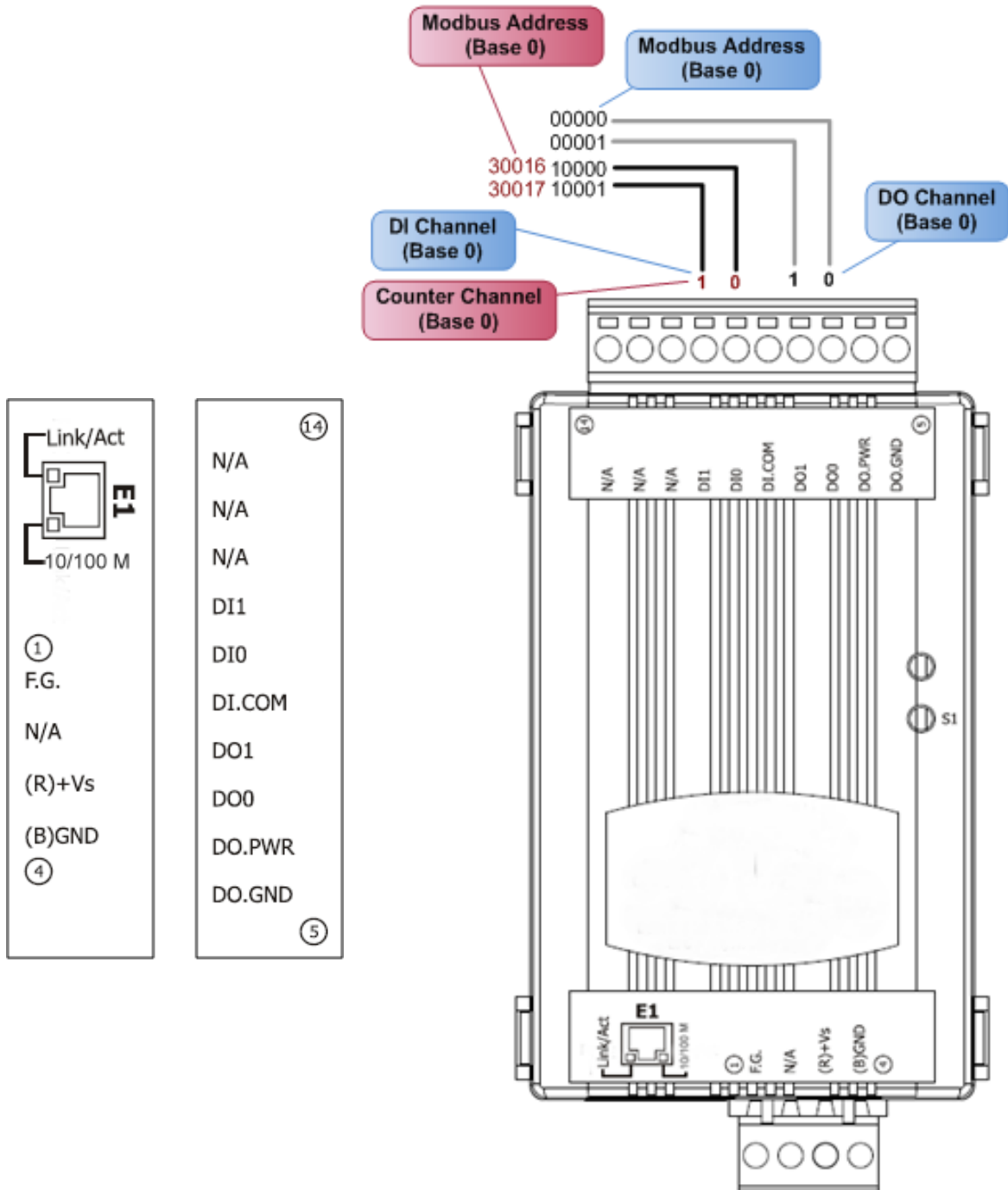

2.3.7 PETL-7060

- : I/O Address Mapping
- : Counter Address Mapping

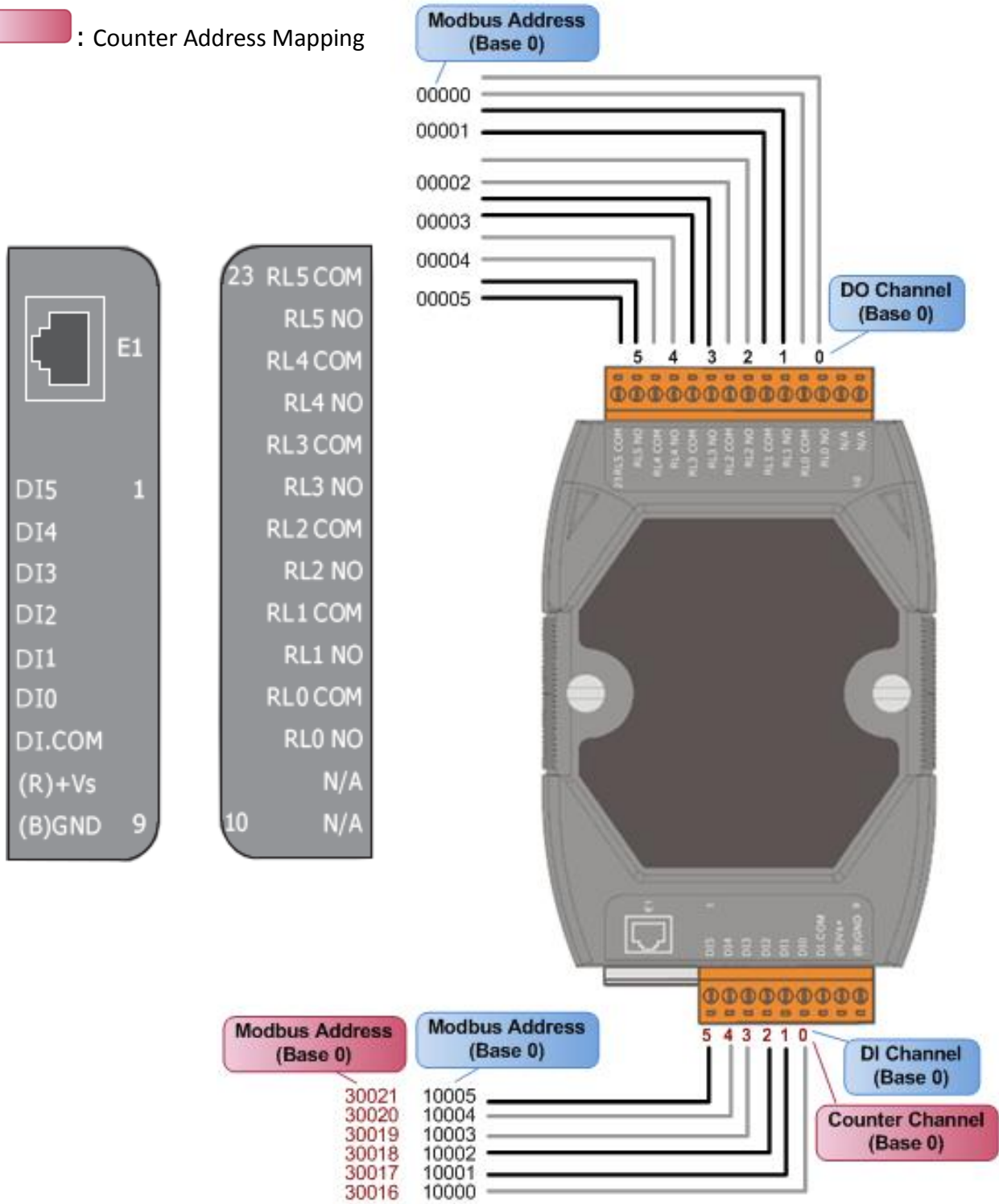

2.4 Wiring Connections

2.4.1 Input Wiring

- tET-P6/ tPET-P6, tET-P2C2/ tPET-P2C2, tET-P2A2/tPET-P2A2, tET-P2POR2/tPET-P2POR2, tET-P2R2 /tPET-P2R2, PETL-7060

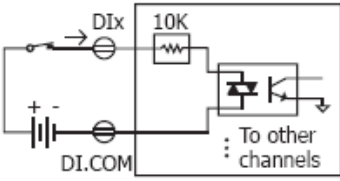
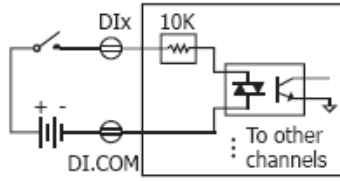
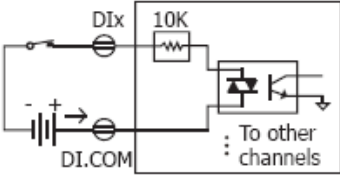
Digital Input	Readback as 1	Readback as 0
Sink	+10 ~ +50 V _{DC} 	OPEN or <4 V _{DC} 
	Source	+10 ~ +50 V _{DC} 

- tET-PD6/tPET-PD6, tET-PD2POR2/tPET-PD2POR2, tET-PD2R1/tPET-PD2R1:

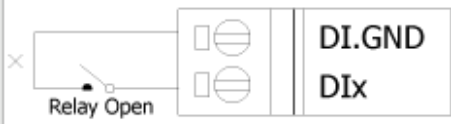
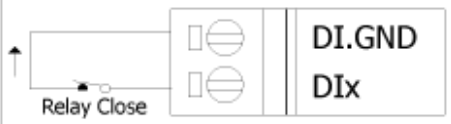
Input Type	Readback as 0	Readback as 1
Dry Contact	Relay Off 	Relay On 

2.4.2 Output Wiring

■ tET-C4/tPET-C4, tET-PC2/tPET-PC2

Output Type	Readback as 1	Readback as 0
	Relay ON	Relay Off
Drive Relay		
Resistance Load		

■ tET-A4/tPET-A4, tET-P2A2/tPET-P2A2

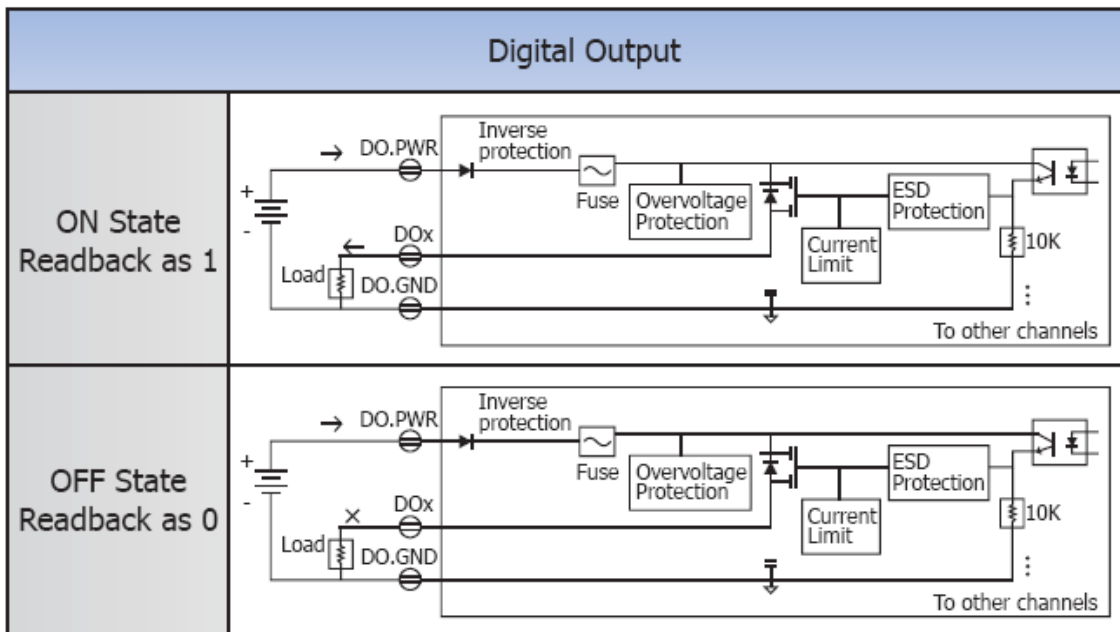

■ tET-P2R2/tPET-P2R2, tET-PD2R1/tPET-PD2R1, PETL-7060

Digital Output	Readback as 1	Readback as 0
	Relay On	Relay Off
Relay Output		

■ tET-P2POR2/tPET-P2POR2, tET-PD2POR2/tPET-PD2POR2

Output Type	Readback as 1	Readback as 0
	Relay On	Relay Off
Form A Relay Contact		

2.5 Dimensions

- The PETL-7060 dimensions are in millimeters.

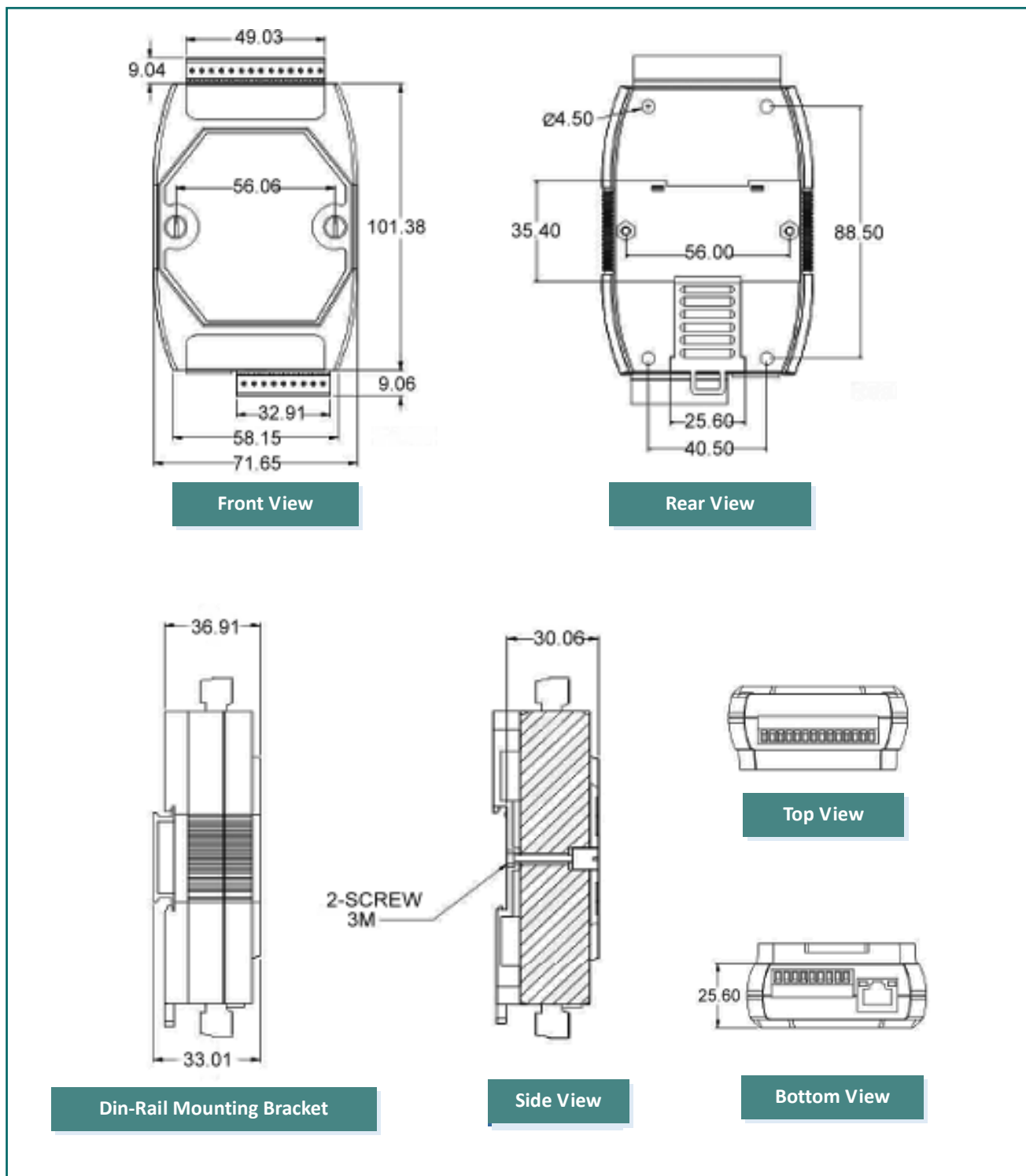

■ The tET/tPET series dimensions are in millimeters.

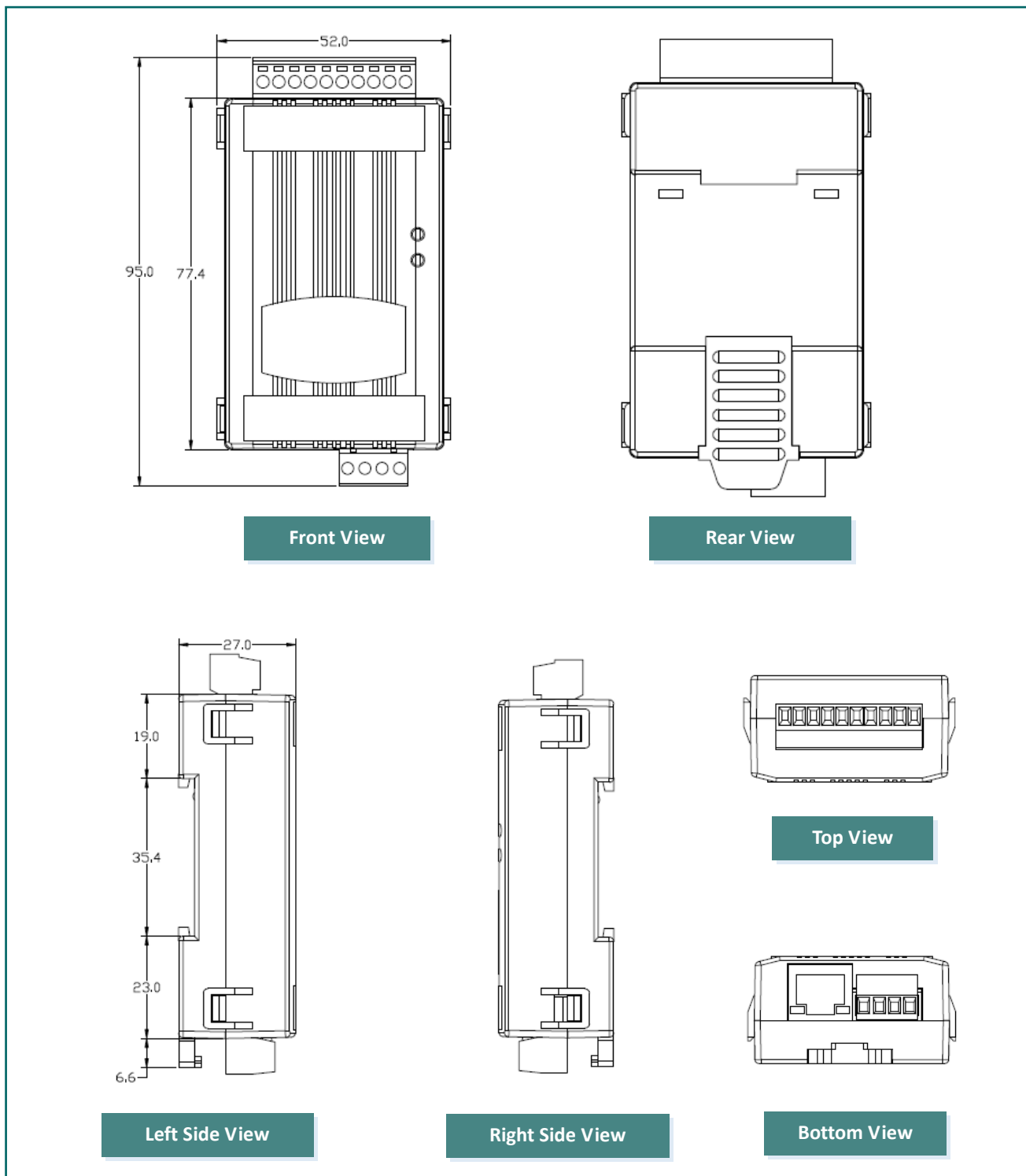

3. Getting Started

This chapter provides a basic overview of how to install, configure and operate your PETL/tET/tPET series module.

3.1 Mounting the Module

The PETL/tET/tPET series module can be mounted by attaching the bottom of the chassis to a DIN-Rail, or the wall or it can be piggybacked to another module.

DIN-Rail Mounting

The PETL/tET/tPET series modules include simple rail clips on the bottom of the chassis that allow them to be reliably mounted on a DIN-Rail or a wall, or they can be piggybacked to another module. For more detailed information regarding DIN-Rail Mountng, refer to the illustration in figure below.

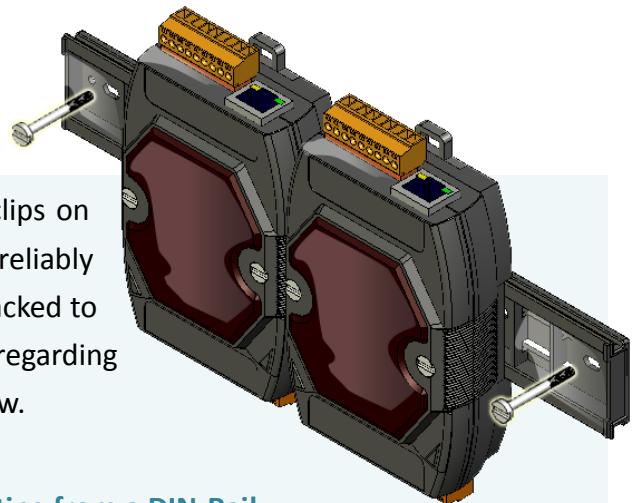

Mounting on a DIN-Rail

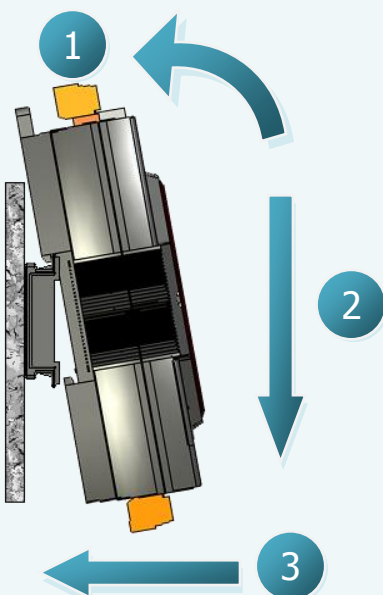

Dismounting from a DIN-Rail

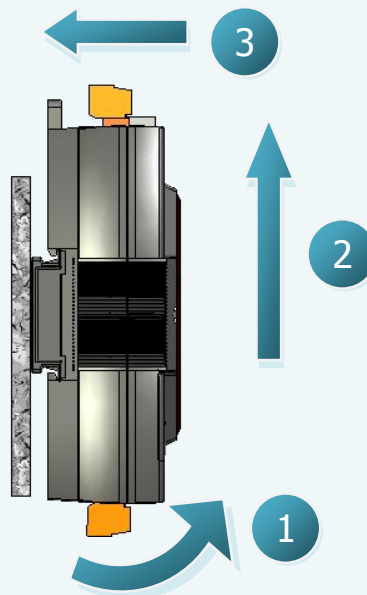

Mountable DIN-Rail Models

Din-Rail mounts are available in three size, and enable a variety of ICP DAS devices to be mounted. Each is made of stainless steel and has a ground wire attached at one end.

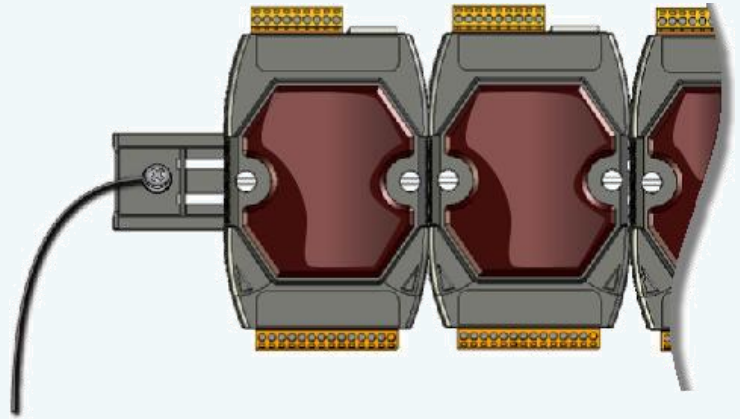

Part Number	Maximum Number of Modules	Dimensions
DRS-125	2	125 mm x 35 mm
DRS-240	3	240 mm x 35 mm
DRS-360	5	360 mm x 35 mm

Piggyback Mounting (for PETL-7060 only)

PETL-7060 module contains holes on each side to enable piggyback mounting.

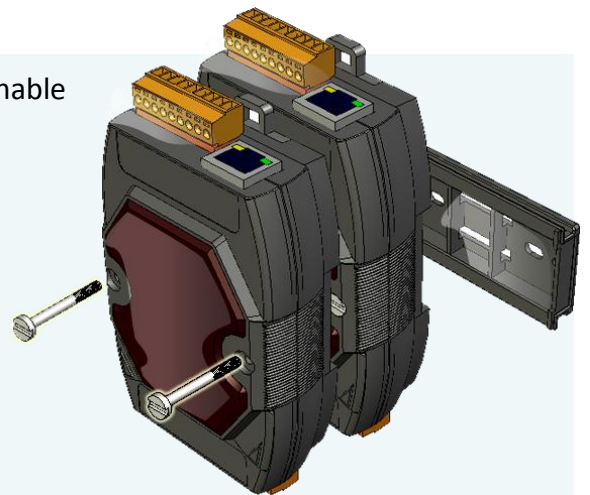

3.2 Configuring the Boot Mode

All PETL/tET/tPET series modules have two operating modes that can be selected by using the switch mechanism incorporated on the chassis. Note that the module must be rebooted after changing the operating mode.

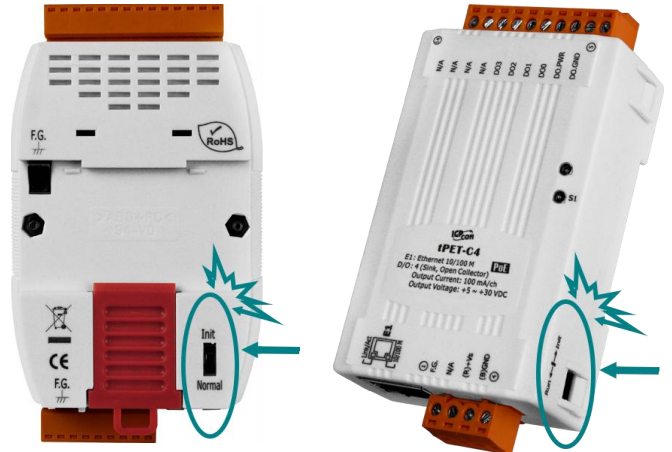

Init Mode

Init Mode should only be selected when updating the firmware or while troubleshooting. This mode forces the module to use the default factory settings.



Run/Normal Mode

Run/Normal Mode is the default operating mode and should be used in most cases.

! Be sure to return the switch to the Run/Normal position once any firmware update is complete.

3.3 Connecting to a Network, a PC and a Power Supply

All PETL/tET/tPET series module are equipped with an RJ-45 Ethernet port to allow connection to an Ethernet hub/switch or a PC.

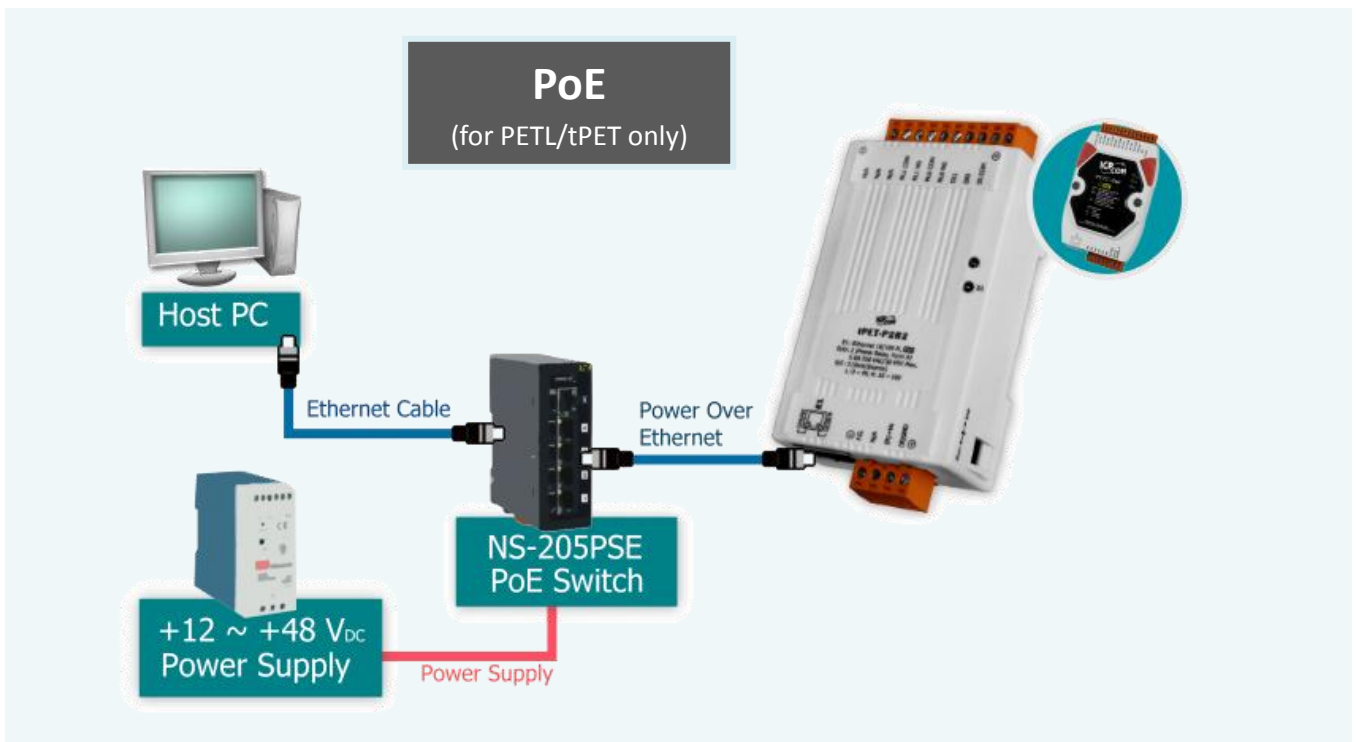
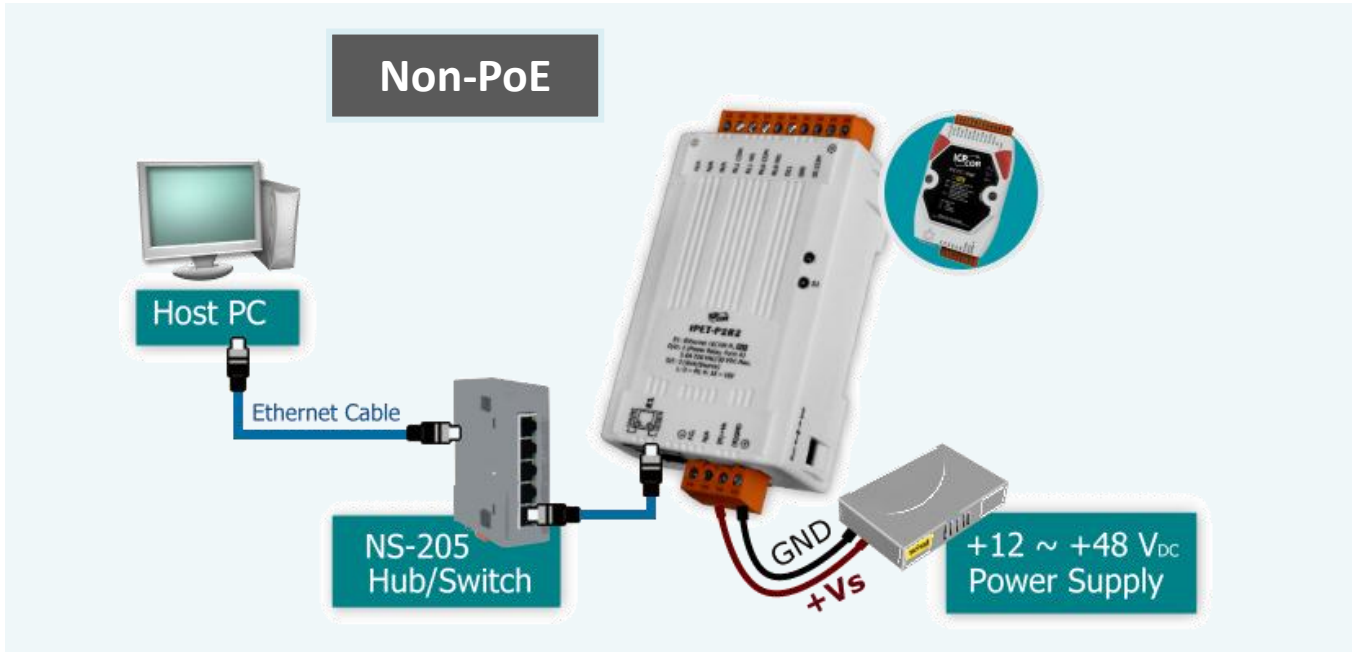

3.4 Using the eSearch Utility to Assign a New IP

The eSearch Utility is a useful tool that provides a quick and easy method of configuring the Ethernet settings for PETL/tET/tPET series module from a PC.

Step 1: Get the eSearch Utility tool

The eSearch Utility can be obtained either from the companion CD at:
CD:\Napdos\Software\eSearch\

Or from the ICP DAS web site at:
<http://ftp.icpdas.com/pub/cd/tinymodules/napdos/software/esearch/>

Step 2: Run the eSearch Utility

Double-click the eSearch Utility icon.



Step 3: Click the “Search Servers” button to search for your module

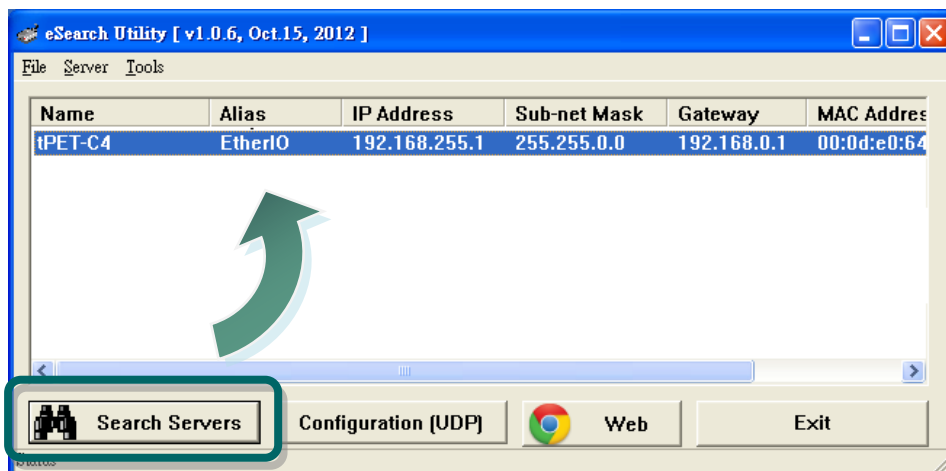

Step 4: Double-click the name of the module to open the server configuration dialog.

All PETL/tET/tPET series modules are IP-based devices that may not be suitable for your network using the default IP address. Therefore, you must first assign a new IP address to the PETL/tET/tPET series module depending on your network settings.

The factory default IP settings are:

IP Address: 192.168.255.1; Subnet Mask: 255.255.0.0; Gateway: 192.168.0.1.

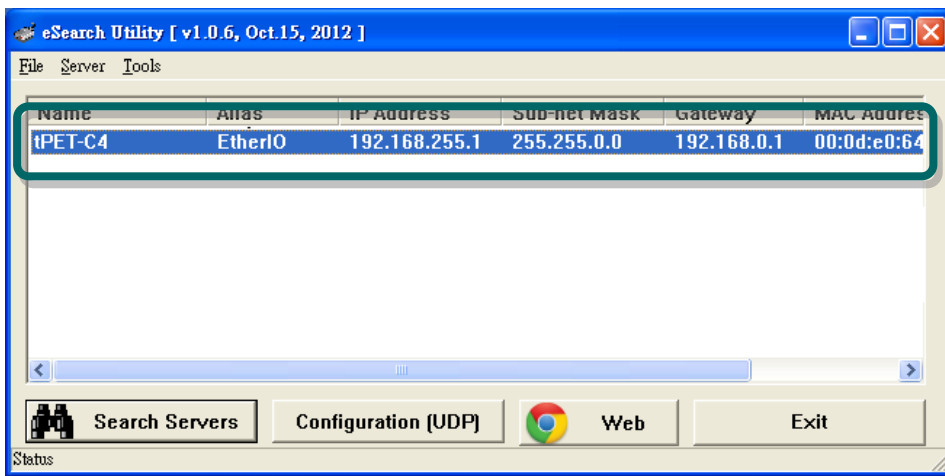

Step 5: Assign a new IP address and then click the “OK” button.

Contact your Network Administrator to obtain the correct network configuration information. Modify the network settings as necessary and then click the “OK” button. The PETL/tET/tPET series module will use the new settings immediately.

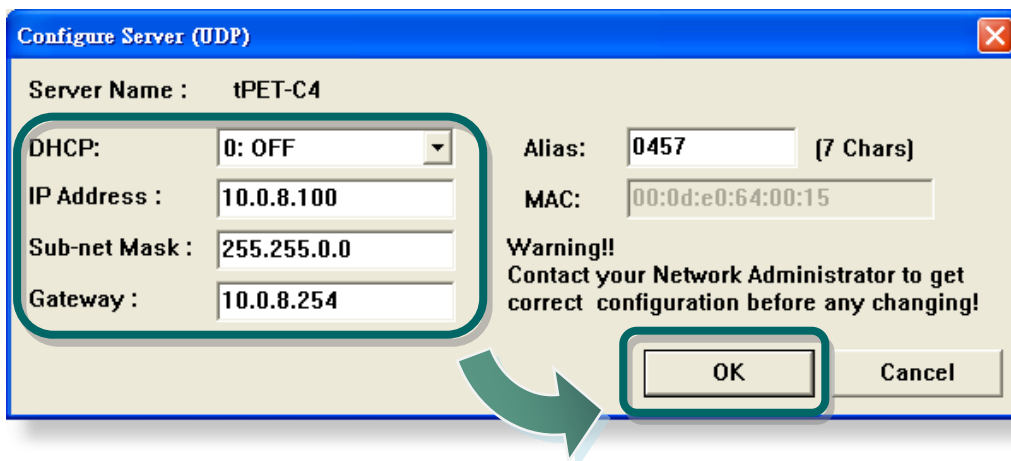

4. Web Configuration

All PETL/tET/tPET series module contain an advanced embedded web configuration system that provides I/O accessibility to the PETL/tET/tPET series module via a web browser.

Logging in to the PETL/tET/tPET Web Server

You can access the embedded PETL/t(P)ET series web server from any computer that has an Internet connection.

Step 1: Open a new browser window.

Open a standard web browser. For example, Mozilla Firefox, Google Chrome and Internet Explorer are reliable and popular internet browsers that can be used to configure PETL/tET/tPET series module.



Note that if you intend to use Internet Explorer, ensure that the cache to functions is disabled in order to avoid browser access errors. Detailed information how to do this can be found in “Appendix: A”.

Step 2: Enter the URL address of the PETL/tET/tPET web server.

Ensure that you have correctly configured the network settings for the PETL/tET/tPET series module, or refer to [Section 3.4 “Using the eSearch Utility to Assign a New IP”](#).

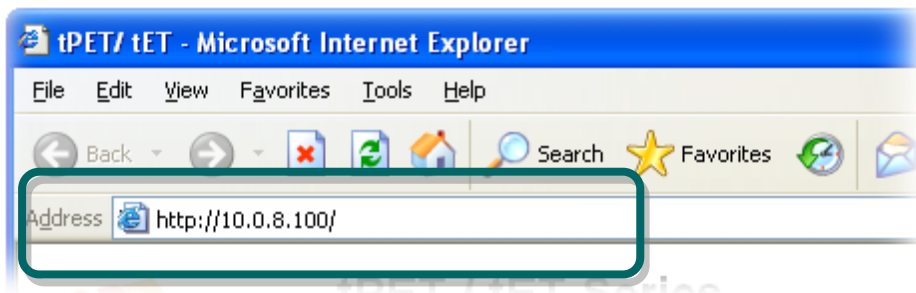

Step 3: Enter the password

After entering the IP address, the main login dialog page will be displayed prompting you to enter a password. The factory default password is “Admin”. Click the “Submit” button to continue.

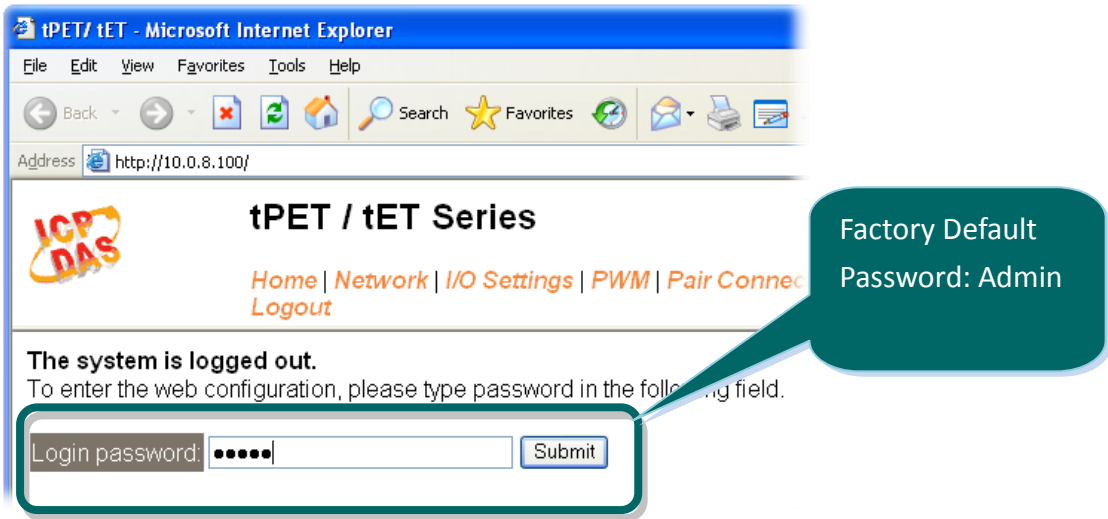

Step 4: Log in to the PETL/tET/tPET web server

After logging into the PETL/tET/tPET web server, the main page will be displayed.

tPET / tET Series

[Home](#) | [Network](#) | [I/O Settings](#) | [PWM](#) | [Pair Connection](#) | [Filter](#) | [Change Password](#) | [Logout](#)

Status & Configuration

Model Name:	tPET-P2R2	Alias Name:	EtherIO
Firmware Version:	v1.1.6 [Feb.16 2011]	MAC Address:	00-0D-E0-6F-FF-FF
IP Address:	10.1.0.67	TCP Port Timeout: (Socket Watchdog, Seconds):	180
Initial Switch:	OFF	System Timeout: (Network Watchdog, Seconds)	0

D/I/O

ALL DI:	Value	Counter / Frequency	High Latched	Low Latched
DI 0:	OFF	0	X	X
DI 1:	OFF	0	X	X
DI 2:	-	-	-	-
DI 3:	-	-	-	-
DI 4:	-	-	-	-
DI 5:	-	-	-	-

4.1 Home Page

Clicking the **Home** tab will display to the main **status & Configuration** page, which is divided into three sections.

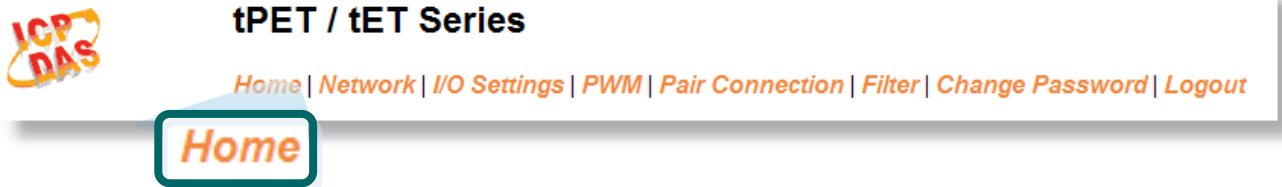

The first section provides basic information related to the PETL/tET/tPET series module hardware and software including the Firmware version and IP Address, etc.

Status & Configuration

Model Name:	tPET-P6	Alias Name:	0457
Firmware Version:	v1.2.8 [Jul.19, 2013]	MAC Address:	00-0d-e0-64-4c-d3
IP Address:	10.0.8.11	TCP Port Timeout: (Socket Watchdog, Seconds):	180
Initial Switch:	OFF	System Timeout: (Network Watchdog, Seconds)	0

The second section provides information related to the current status of the I/O.

DII/DO

ALL DI:	Value	Counter / Frequency	High Latched	Low Latched
DI 0:	ON	-	-	-
DI 1:	OFF	-	-	-
DI 2:	OFF	-	-	-
DI 3:	OFF	-	-	-
DI 4:	OFF	-	-	-
DI 5:	OFF	-	-	-
DI 6:	-	-	-	-
DI 7:	-	-	-	-
DI 8:	-	-	-	-
DI 9:	-	-	-	-
DI 10:	-	-	-	-
DI 11:	-	-	-	-

DO7	-	DO6	-	DO5	-	DO4	-	DO3	-	DO2	-	DO1	-	DO0	-
-----	---	-----	---	-----	---	-----	---	-----	---	-----	---	-----	---	-----	---

The third section provides details related to the status of the I/O pair-connections.

Current port settings:

Pair-Connection Settings	Port 1
Server Mode:	Server
Remote Server IP:	Disabled
Remote TCP Port:	Disabled

4.2 Network Settings



tPET / tET Series

[Home](#) | [Network](#) | [I/O Settings](#) | [PWM](#) | [Pair Connection](#) | [Filter](#) | [Change Password](#) | [Logout](#)

Network

Clicking the **Network** tab will display the **Network and Miscellaneous Settings** page allowing you verify the current settings and configure the IP Address parameters, configure the general parameters and restore the default settings for the PETL/tET/tPET device, each of which will be described in more detail below.

4.2.1 Network and Miscellaneous Settings

The **Network and Miscellaneous Settings** page allows you to check the Model name and other information related to the hardware and software.

Network and Miscellaneous Settings

Model Name:	tPET-P6	Alias Name:	0457
Firmware Version:	v1.2.8 [Jul.19, 2013]	MAC Address:	00-0d-e0-64-4c-d3
IP Address:	10.0.8.11	TCP Port Timeout: (Socket Watchdog, Seconds):	180
Initial Switch:	OFF	System Timeout: (Network Watchdog, Seconds)	0

The software and hardware information section includes the following items:

The Model Name, Firmware version, IP Address, Initial Switch position, Alias Name, MAC Address, and the TCP Port and System Timeout values. If the firmware for the PETL/tET/tPET device is updated, you can use this page to check the version information for the PETL/tET/tPET software.

4.2.2 IP Address Configuration

IP Address Configuration

Address Type:	DHCP <input type="button" value="v"/>		
Static IP Address:	<input type="text" value="0"/>	<input type="text" value="0"/>	<input type="text" value="0"/>
Subnet Mask:	<input type="text" value="0"/>	<input type="text" value="0"/>	<input type="text" value="0"/>
Default Gateway:	<input type="text" value="0"/>	<input type="text" value="0"/>	<input type="text" value="0"/>
MAC Address:	<input type="text" value="00-0d-e0-64-4c-d3"/> (Format: FF-FF-FF-FF-FF-FF)		
	Modbus TCP Slave		
Local Modbus TCP port	<input type="text" value="502"/> (Default= 502)		
Local Modbus NetID	<input type="text" value="1"/> (Default= 1)	<input type="button" value="Enable"/> <input type="button" value="v"/>	(Default= Enable)
<input type="button" value="Update Settings"/>			

The following table provides an overview of the parameters contained in the IP Address configuration section:

Item	Description
Address Type	Static IP: If there is no DHCP server installed in your network, you can configure the network settings manually. Refer to Section “4.2.2.2 Manual Configuration” for more details.
	DHCP: Dynamic Host Configuration Protocol (DHCP) is a network application protocol that automatically assigns an IP address to each device. Refer to Section “4.2.2.1 Dynamic Configuration” for more details.
Static IP Address	Each PETL/tET/tPET device connected to the network must have its own unique IP address. This parameter is used to assign a specific IP address.
Subnet Mask	This parameter is used to assign the subnet mask for the PETL/tET/tPET device. The subnet mask indicates which portion of the IP address is used to identify the local network or subnet.
Default Gateway	This parameter is used to assign the IP Address of the Gateway to be used by the PETL/tET/tPET device. A Gateway (or router) is a device that is used to connect an individual network to one or more additional networks.
MAC Address	This parameter is used to set the User-defined MAC address, which must be in the format FF-FF-FF-FF-FF-FF.

Modbus TCP Slave	
Local Modbus TCP port	This parameter is used to set the local port to be used by the Modbus slave device. The default value is 502.
Local Modbus Net ID	This parameter is used to set the Network ID to be used by the Modbus slave device. The default value is 1.
Update Settings	Click this button to save the revised settings to the PETL/tET/tPET device.

4.2.2.1 Dynamic Configuration

Dynamic configuration is very easy to perform. If a DHCP server is connected to you network, a network address can be dynamically configured by using the following procedure:

Step 1: Select “DHCP” from the **Address Type** drop-down menu.

Step 2: Click the “Update Settings” button to complete the configuration.

IP Address Configuration

Address Type:	DHCP	1
Static IP Address:	0 . 0 . 0 . 0	
Subnet Mask:	0 . 0 . 0 . 0	
Default Gateway:	0 . 0 . 0 . 0	
MAC Address:	00-08-e0-64-4c-d3	(Format: FF-FF-FF-FF-FF-FF)
Modbus TCP Slave		
Local Modbus TCP port	502	(Default= 502)
Local Modbus NetID	1	(Default= 1) Enable (Default= Enable)
Update Settings 2		

4.2.2.2 Manual Configuration

When using manual configuration, the network settings should be assigned in the following manner:

Step 1: Select “**Static IP**” from the **Address Type** drop-down menu.

Step 2: Enter the relevant details in the respective **network settings** fields.

Step 3: Click the “**Update Settings**” button to complete the configuration.

The screenshot shows a network configuration form with the following fields and values:

Address Type:	Static IP	1
Static IP Address:	10 . 0 . 8 . 100	2
Subnet Mask:	255 . 255 . 255 . 0	
Default Gateway:	10 . 0 . 8 . 254	
MAC Address:	00-0d-e0-64-4c-d3	(Format: FF-FF-FF-FF-FF-FF)
		Modbus TCP Slave
Local Modbus TCP port	502	(Default= 502)
Local Modbus NetID	1	(Default= 1) Enable (Default= Enable)
	<input type="button" value="Update Settings"/>	3

4.2.3 General Configuration Settings

General Settings

Ethernet Speed:	Auto <input type="button" value="v"/> (Auto=10/100 Mbps Auto-negotiation)
System Timeout: (Network Watchdog)	0 (30 ~ 65535 s, Default= 0, Disable= 0) Action:Reboot
TCP Timeout:	180 (5 ~ 65535 s, Default= 180, Disable= 0) Action:Cut-off
Web Auto-logout:	10 (1 ~ 65535 minutes, Default= 10, Disable= 0)
Alias Name:	0457 (Max. 18 chars)
<input type="button" value="Update Settings"/>	

The following table provides an overview of the parameters contained in the General Settings section:

Item	Description
Ethernet Speed	This parameter is used to set the Ethernet speed. The default value is Auto (Auto = 10/100 Mbps Auto-negotiation).
System Timeout (Network Watchdog)	This parameter is used to configure the system timeout value. If there is no activity on the network for a certain period of time, the system will be rebooted based on the configured system timeout value.
TCP Timeout (Seconds)	This parameter is used to configure the TCP timeout value. If Modbus TCP communication is idle for a certain period of time, the system will cut off the connection.
Web Auto-logout	This parameter is used to configure the automatic logout value. If there is no activity on the web server for a certain period of time, the current user account will automatically logged out.
Alias Name	This parameter is used to assign an alias name for each PETL/tET/tPET device to assist with easy identification.
Update Settings	Click this button to save the revised settings to the PETL/tET/tPET device.

4.2.4 Restoring Factory Defaults

Restore Factory Defaults

Restore all options to their factory default states:	<input type="button" value="Restore Defaults"/>
Forced Reboot	<input type="button" value="Reboot"/>

■ To reset all parameters to their original factory default settings, use the following procedure:

Step 1: Click the “Restore Defaults” button to reset the configuration.

Step 2: Click the “OK” button in the message dialog box.

Step 3: Check whether the module has been reset to the original factory default settings for use with the eSearch Utility. Refer to [Section 3.4 Using the eSearch Utility to assign a new IP](#)”.

Restore Factory Defaults

The diagram illustrates the three-step process for restoring factory defaults. Step 1 shows the 'Restore Defaults' button in the configuration interface. Step 2 shows a warning dialog box from Microsoft Internet Explorer stating: 'This will erase all existing configuration changes and restore factory default settings. Click OK if you want to do this or Cancel to retain existing settings.' Step 3 shows the eSearch Utility window with the 'Configuration (UDP)' tab selected, displaying a table of server information.

Name	Alias	IP Address
tPET-C4	EtherIO	192.168.255.1

The following table provides an overview of the factory default settings:

Factory Default Settings	
Network Settings	
IP Address	192.168.255.1
Gateway Address	192.168.0.1
Subnet Mask	255.255.0.0
DHCP	Disabled
Basic Settings	
Alias Name	EtherIO

- The Forced Reboot function: can be used to force the PETL/tET/tPET device to reboot or to remotely reboot for the device. After the tET/tPET module has rebooted, the original login screen will be displayed requesting that you enter your Login Password before continuing.

The image shows a sequence of two screenshots. The top screenshot shows a 'Forced Reboot' button in red text on the left and a 'Reboot' button in a blue box on the right. A green arrow points from the 'Reboot' button down to the second screenshot. The second screenshot shows the login page for 'tPET / tET Series'. It features the ICP DAS logo, a navigation menu with links like Home, Network, I/O Settings, PWM, Pair Connection, Filter, and Char. Below the menu, it says 'The system is logged out.' and 'To enter the web configuration, please type password in the following field.' There is a 'Login password:' label, an input field, and a 'Submit' button. A red note at the bottom states: 'Note: This web configuration requires JavaScript enabled in your browser (Firefox, IE...). If the web configuration does not work, please check the JavaScript settings first. When using IE, please disable its cache as follows. Menu items: Tools / Internet Options... / General / Temporary Internet Files / Settings... / Every v'.

4.3 I/O Settings



tPET / tET Series

[Home](#) | [Network](#) | [I/O Settings](#) | [PWM](#) | [Pair Connection](#) | [Filter](#) | [Change Password](#) | [Logout](#)

I/O Settings

Clicking the **I/O Settings** tab will display the **I/O Settings** page allowing you configure the Digital Input and Digital Output parameters for the PETL/tET/tPET device. This page including Digital Output control, DI/DO Configuration, etc., each of which will be described in more detail below.

4.3.1 DO Control

DO Control

Set DO Value <i>[Advanced Setting]</i>	<input type="text" value="0x0"/> bit 7~4(<input type="checkbox"/> <input type="checkbox"/> <input type="checkbox"/> <input type="checkbox"/>) bit 3~0(<input type="checkbox"/> <input type="checkbox"/> <input type="checkbox"/> <input type="checkbox"/>)
<input type="button" value="Update Settings"/>	

The following table provides an overview of the parameters contained in the Digital Output Control section:

Item	Description
Set DO value	This parameter is used to manually assign a specific a value for the DO.
Update Settings	Click this button to save the revised settings to the PETL/tET/tPET device.

4.3.2 DI/DO Configuration

DI/DO Configuration:

		Digital Output
Host Watchdog Timeout (seconds):	<input type="text" value="0"/>	(5 ~ 65535 Seconds, Default= 0, Disable= 0)
Safe Value	<input type="text" value="0x0"/>	bit 7~4(<input type="checkbox"/> <input type="checkbox"/> <input type="checkbox"/> <input type="checkbox"/>) bit 3~0(<input type="checkbox"/> <input type="checkbox"/> <input type="checkbox"/> <input type="checkbox"/>)
Power-On Value	<input type="text" value="0x0"/>	bit 7~4(<input type="checkbox"/> <input type="checkbox"/> <input type="checkbox"/> <input type="checkbox"/>) bit 3~0(<input type="checkbox"/> <input type="checkbox"/> <input type="checkbox"/> <input type="checkbox"/>)
		Digital Counter
Enable Digital Counter	<input type="text" value="0x0"/>	Ch 7~4(<input type="checkbox"/> <input type="checkbox"/> <input type="checkbox"/> <input type="checkbox"/>) Ch 3~0(<input type="checkbox"/> <input type="checkbox"/> <input type="checkbox"/> <input type="checkbox"/>)
Clear Digital Counter	<input type="text" value="0x0"/>	Ch 7~4(<input type="checkbox"/> <input type="checkbox"/> <input type="checkbox"/> <input type="checkbox"/>) Ch 3~0(<input type="checkbox"/> <input type="checkbox"/> <input type="checkbox"/> <input type="checkbox"/>)
Preset Counter Value	<input type="text" value="0"/>	Ch7 <input type="text" value="0"/> Ch6 <input type="text" value="0"/> Ch5 <input type="text" value="0"/> Ch4 <input type="text" value="0"/> Ch3 <input type="text" value="0"/> Ch2 <input type="text" value="0"/> Ch1 <input type="text" value="0"/> Ch0 <input type="text" value="0"/>
		Frequency Measurement by DI
Enable Frequency Measurement	<input type="text" value="0x1"/>	Ch 7~4(<input type="checkbox"/> <input type="checkbox"/> <input type="checkbox"/> <input type="checkbox"/>) Ch 3~0(<input type="checkbox"/> <input type="checkbox"/> <input type="checkbox"/> <input type="checkbox"/>)
Scan Mode	<input type="text" value="1000 ms"/>	1000 ms: 1 Hz ~ 3.5 kHz (+/- 1 Hz error). 100 ms: 100 Hz to 3.5 kHz (+/- 10 Hz error). Single-pulse: 0.01 Hz ~ 3.5 kHz (+/- 0.01 Hz error), for stable signal only.
Moving Average	<input type="text" value="1"/>	
		Digital Input
Enable Latched DI	<input type="text" value="0"/>	(Disable All= 0, Enable All= 1)
Clear Latched Status (High)	<input type="text" value="0"/>	(No Operation= 0, Clear All= 1)
Clear Latched Status (Low)	<input type="text" value="0"/>	(No Operation= 0, Clear All= 1)
		<input type="button" value="Update Settings"/>

The following table provides an overview of the parameters contained in the DI/DO Configuration section:

Item	Description
Digital Output	
Host Watchdog Timeout (Seconds)	This parameter is used to configure the Host Watchdog timeout value. If there is no Modbus TCP communication activity for the specified period (the timeout), then the Host Watchdog will activate an alarm.
Safe Value	This parameter is used to define the DO safe value for the PETL/tET/tPET module. If the Host Watchdog alarm is activated, the DO will be set to the user-defined safe value.
Power-On Value	This parameter is used to define the DO Power-on value. On boot up, the DO is set to the user-defined Power-on value.

Digital Counter	
Enable Digital Counter	This parameter is used to enable the digital counter function on all DI channels.
Clear Digital Counter	This parameter is used to clear the values of all DI counters.
Preset Counter Value	This parameter is used to set the default value for all DI counters.
Frequency Measurement by DI	
Enable Frequency Measurement	This parameter is used to enable the frequency measurement function on all DI channels.
Scan Mode	<p>This parameter is used to define the scan mode to be used for the frequency measurement.</p> <p>1000 ms: This mode provides a normal update rate and normal accuracy. The acceptable frequency range for the input signal is 1 Hz to 3.5 kHz (± 1 Hz error). This mode can be used when the pulse width (signal source) contains small errors, since the measurement is based on the pulse count.</p> <p>100 ms: This mode provides fast update rate, but the accuracy is low. The acceptable frequency range for the input signal is 100 Hz to 3.5 kHz (± 10 Hz error). This mode can be used when the pulse width (signal source) contains small errors, since the measurement is based on the pulse count.</p> <p>Single-pulse: This mode provides the highest accuracy but can only be used for stable signal. The data update rate depends on the signal frequency and the acceptable signal frequency range for the input signal is 0.01 Hz to 3.5 kHz (± 0.01 Hz error). This mode can only be used when the pulse width (signal source) is stable, since the measurement is based on the width of a single pulse.</p>
Moving Average	<p>1 ==> No Average is used</p> <p>2 ==> Uses the average of 2 continuous sample values</p> <p>4 ==> Uses the average of 4 continuous sample values</p> <p>8 ==> Uses the average of 8 continuous sample values</p>
Digital Input	
Enable Latched DI	This parameter is used to enable the latch function on all DI channels. The status of the DI will be recorded if it has been flagged as either high or low. 0 = Disable All; 1 = Enable All
Clear Latched Status (High)	This parameter is used to clear the status of all high latched counters. 0 = No Operation; 1 = Clear All
Clear Latched Status (Low)	This parameter is used to clear the status of all low latched counters. 0 = No Operation; 1 = Clear All = 1
Update Settings	Click this button to save the revised settings of DI/DO configuration to the PETL/tET/tPET device.

4.4 PWM



tPET / tET Series

[Home](#) | [Network](#) | [I/O Settings](#) | **PWM** | [Pair Connection](#) | [Filter](#) | [Change Password](#) | [Logout](#)



Clicking the **PWM** tab will display the **PWM Configuration** page allowing you enable and configure the PWM parameters for the PETL/tET/tPET device, including the PWM Alarm and duty cycle, etc., each of which will be described in more detail below.

4.4.1 PWM Configuration

PWM Configuration:

Enable PWM	<input type="text" value="0x0"/> Ch 7~4(<input type="checkbox"/> <input type="checkbox"/> <input type="checkbox"/> <input type="checkbox"/>) Ch 3~0(<input type="checkbox"/> <input type="checkbox"/> <input type="checkbox"/> <input type="checkbox"/>)
Enable PWM Alarm	<input type="text" value="0x0"/> Ch 7~4(<input type="checkbox"/> <input type="checkbox"/> <input type="checkbox"/> <input type="checkbox"/>) Ch 3~0(<input type="checkbox"/> <input type="checkbox"/> <input type="checkbox"/> <input type="checkbox"/>) (When Host/Slave Watchdog Timeout)
Duty Cycle	<input type="text" value="0"/> <input type="text" value="0"/>)DO0 <input type="text" value="0"/> <input type="text" value="0"/>)DO1 <input type="text" value="0"/> <input type="text" value="0"/>)DO2 <input type="text" value="0"/> <input type="text" value="0"/>)DO3 <input type="text" value="0"/> <input type="text" value="0"/>)DO4 <input type="text" value="0"/> <input type="text" value="0"/>)DO5 <input type="text" value="0"/> <input type="text" value="0"/>)DO6 <input type="text" value="0"/> <input type="text" value="0"/>)DO7 (High, Low: 10 ~ 65535 ms, 0= Disable)
<input type="button" value="Update Settings"/>	

The following table provides an overview of the parameters contained in the PWM Configuration section:

Item	Description	Default Value
Enable PWM	This parameter is used to enable the PWM output function.	0
Enable PWM Alarm	This parameter is used to enable the PWM output alarm function.	0
Duty Cycle	This parameter is used to set the duty cycle for the DO channels. Two values are required for each DO channel. The first value is the high pulse width, while the second is the low pulse width. The duty cycle is in 1 ms units, and the resolution is approximately 5 ms. (5 to 65535 ms). A value of 0 will disable the duty cycle functions for that channel.	1000 (ms)
Update Settings	Click this button to save the revised settings to the PETL/tET/tPET device.	



Because of the characteristics of the relay functions, it is recommended that the PWM on t(P)ET-P(D)2POR2/ t(P)ET-P2R2/ t(P)ET-PD2R1/PETL-7060 series modules(i.e., modules with relay functions) is not used for extended periods of time.

4.5 Pair Connection



tPET / tET Series

[Home](#) | [Network](#) | [I/O Settings](#) | [PWM](#) | [Pair Connection](#) | [Filter](#) | [Change Password](#) | [Logout](#)

Pair Connection

Clicking the **Pair Connection** tab will display the pair connections **Settings** page allowing you enable and configure the DI-to-DO pair connections for the PETL/tET/tPET device, which will be described in more detail below.

4.5.1 Settings

The I/O pair connection function is a specific feature of the PETL/tET/tPET series modules that can be used to enable a pair of DI-to-DO connections via the Modbus TCP (Ethernet) protocol.

Settings:

The following options are used on client-mode, ignored on server-mode.

I/O Pair-Connection	Current	Updated
Server Mode:	Server	Server <input type="button" value="v"/> (Server=Slave, Client=Master)
Remote Server IP:	Disabled	10 . 1 . 120 . 53
Remote TCP Port:	Disabled	502 (Default: 502)
Connection Timeout:	5	5 (Default: 5 s)
Remote Net ID:	1	1 (Default: 1)
Scan Time:	1000	1000 (Default: 1000 ms)
Remote DI to Local DO	Current	Updated (Polling in Client Mode)
Remote DI Count:	0	0 (Disable: 0)
Remote DI Address:	0	0 (Default: 0)
Local DO Address:	0	0 (Default: 0)
Local DI to Remote DO	Current	Updated (Push in Client Mode)
Modbus Protocol:	TCP	TCP <input type="button" value="v"/>
Local DI Count:	0	0 (Disable: 0)
Local DI Address:	0	0 (Default: 0)
Remote DO Address:	0	0 (Default: 0)
Force Update Time:	30	30 (Default: 30 s)

The following table provides an overview of the parameters contained in the I/O Pair Connection section:

Item	Description	Default Value
I/O Pair-Connection		
Server Mode	This parameter is used to set the Server mode. The Remote or Local DI Count field must also be configured to enable client mode. Server = Slave; Client = Master	Server
Remote Server IP	This parameter is used to set the IP address for the remote device.	0
Remote TCP Port	This parameter is used to set the Port number for the remote device. Range: 0 to 65535.	502
Connection Timeout	This parameter is used to set the maximum period of time that should elapse before abandoning an attempt to establish a connection.	5 seconds
Remote Net ID	This parameter is used to set Modbus Net ID for the remote device. Range: 1 to 247.	1
Scan Time	This parameter is used to set the time period required to update the status of the DI/DO channels. Range: 1000 to 42949672965 ms.	1000 ms
Remote DI to Local DO (Polling in Client Mode)		
Remote DI count	This parameter is used to set the DI count that is mapped from the base address. Range: 1 to 255; 0= Disable.	0
Remote DI Address	This parameter is used to set the base address of the Remote DI device that will be mapped to the Local DO register. The range: depends on the type of remote device being used.	0
Local DO Address	This parameter is used to set the base address of the Local DO register that will be mapped to the Remote DI device. The range depends on the type of PETL/tET/tPET module being used.	0
Local DI to Remote DO (Push in Client Mode)		
Modbus Protocol	This parameter is used to set the type of Modbus protocol to be used and can be either TCP or UDP.	TCP
Local DI Count	This parameter is used to set the DI count that is mapped from the base address. Range: 1 to 255; 0= Disable.	0
Local DI Address	This parameter is used to set the base address of Local DI register that will be mapped to the Remote DO device. The range depends on the type of PETL/tET/tPET module being used.	0
Remote DO Address	This parameter is used to set the base address of the Remote DO device that will be mapped to the Local DI register. The range depends on the type of remote device being used.	0
Force Update Time	This parameter is used to set the period of time that should elapse before an update is forced.	30 seconds
Submit	Click this button to save the revised settings to PETL/tET/tPET device.	

4.6 Filter



tPET / tET Series

[Home](#) | [Network](#) | [I/O Settings](#) | [PWM](#) | [Pair Connection](#) | [Filter](#) | [Change Password](#) | [Logout](#)

Filter

Clicking the **Filter** tab will display the **Filter Settings** page allowing you configure the IP Filter list for the PETL/tET/tPET device, which will be described in more detail below.

4.6.1 Filter Settings

The **Filter Settings** page is used to query or edit the IP Filter List for the PETL/tET/tPET series module. The IP filter list restricts the access of incoming packets based on the IP header. If one or more IP addresses are saved to the IP Filter table, only Clients whose IP address is specified in the IP Filter List will be able to access the PETL/tET/tPET series module.

Filter Settings:

IP Filter List	IP Address
IP1:	0.0.0.0
IP2:	0.0.0.0
IP3:	0.0.0.0
IP4:	0.0.0.0
IP5:	0.0.0.0

Add . . . To The List
 Delete IP#
 Delete ALL
 Save to Flash

The following table provides an overview of the parameters contained in the IP Address Configuration section:

Item	Description
Add "IP" to the List	This parameter is used to add an IP address to the IP Filter List.
Delete IP # "number"	This parameter is used to delete IP# address from the IP Filter List.
Delete All	This parameter is used to delete all IP address current contained in the IP Filter List.
Save to Flash	This parameter is used to save the updated IP Filter List to the Flash memory. Check the checkbox before clicking the Submit button of you wish to stor the most recent list.
Submit	Click this button to save the revised settings to PETL/tET/tPET device.

4.7 Change Password

Clicking the **Change Password** tab will display the **Change Password** page. To change a password, first enter the old password in the **“Current password”** field (default is **Admin**) and then enter a new password in the **“New password”** field. Re-enter the new password in the **“Confirm new password”** field, and then click the **“Submit”** button to update the password.

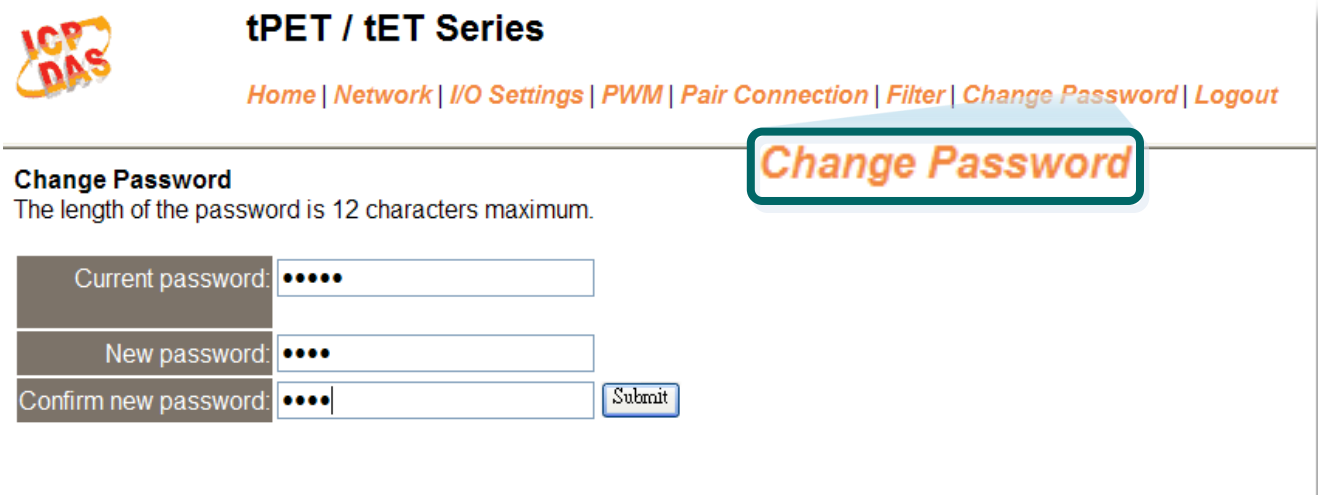

The screenshot shows the web interface for the tPET / tET Series. At the top left is the ICP DAS logo. The page title is "tPET / tET Series". A navigation menu includes: Home | Network | I/O Settings | PWM | Pair Connection | Filter | Change Password | Logout. The "Change Password" tab is highlighted with a green box. Below the navigation is the "Change Password" section. It states: "The length of the password is 12 characters maximum." There are three input fields: "Current password:" with five dots, "New password:" with four dots, and "Confirm new password:" with three dots. A "Submit" button is to the right of the third field. A large green box highlights the "Change Password" tab in the navigation menu.

4.8 Logout

Clicking the **Logout** tab will immediately log you out from the system and return you to the login page.



The screenshot shows the web interface for the tPET / tET Series. At the top left is the ICP DAS logo. The page title is "tPET / tET Series". A navigation menu includes: Home | Network | I/O Settings | PWM | Pair Connection | Filter | Change Password | Logout. The "Logout" tab is highlighted with a green box. Below the navigation is the "Logout" section. It states: "The system is logged out." and "To enter the web configuration, please type password in the following field." There is one input field labeled "Login password:" and a "Submit" button. Below the input field is a red note: "Note: This web configuration requires JavaScript enabled in your browser (Firefox, IE...). If the web configuration does not work, please check the JavaScript settings first." Below the note is another red note: "When using IE, please disable its cache as follows. Menu items: Tools / Internet Options... / General / Temporary Internet Files / Settings... / Every visit to the page". A large green box highlights the "Logout" tab in the navigation menu.

5. I/O Pair Connection Applications

The PETL/tET/tPET series of modules can be used to create DI-to-DO pair connections via the Ethernet. Once the configuration is complete, the modules can then poll the status of the local DI channels and then use the Modbus/TCP protocol to continuously write to a remote DO device in the background. This is useful when connecting digital I/O devices that do not themselves have Ethernet capability. The following will describe how to correctly configure the I/O pair connection function.

5.1 One Module Polling the Remote DI/DO (1-to-1, Polling Mode)

Step 1: Connect the device to a Network, a PC and a Power supply.

Confirm that the PETL/tET/tPET series modules are functioning correctly. Refer to [Section 3. Getting Started](#) for more details. An example configuration shown below:

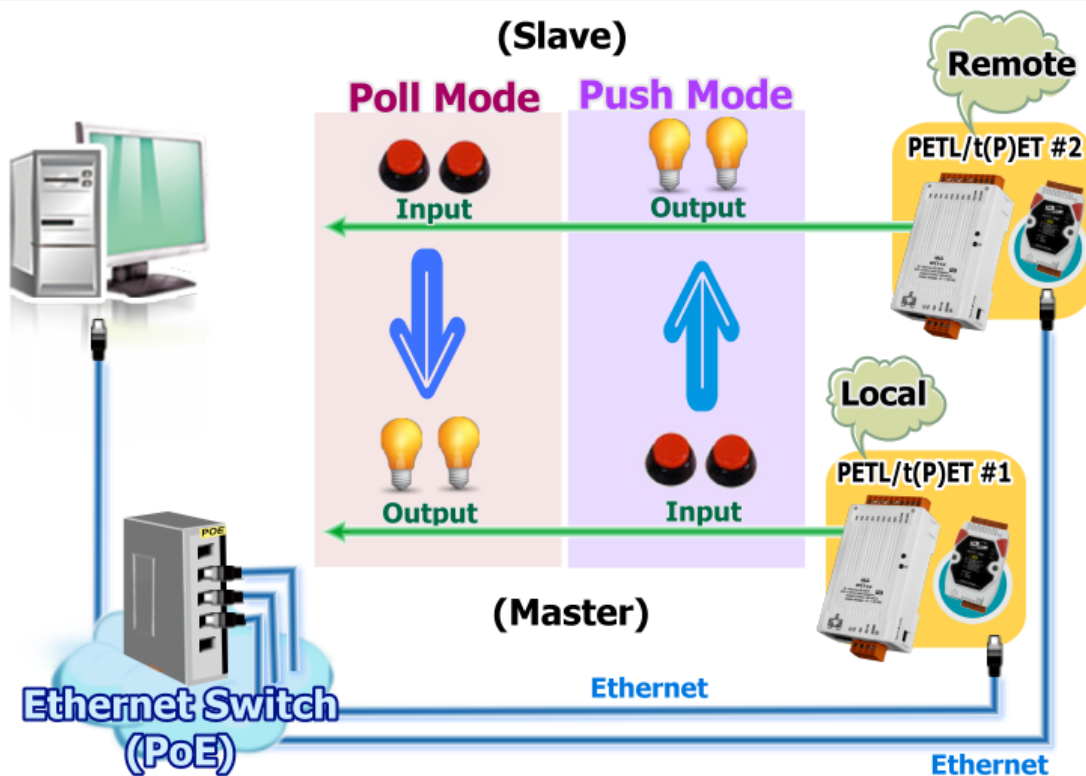

Step 2: Configure the Ethernet Settings

Contact your Network Administrator to obtain a the correct network configuration information for the PETL/tET/tPET series modules, such as the IP Address, Subnet Mask, and Gateway details. Refer to [Section 3.4 Using the eSearch Utility to assign a new IP.](#) for more details.

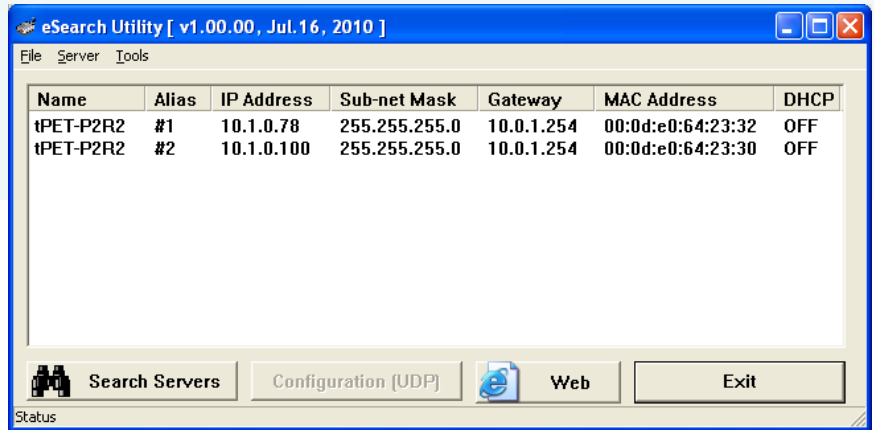

Figure 5-1

Step 3: Configure the I/O Pair connection on the Web Server

1. In the eSearch Utility, select **PETL/tET/tPET module #1** and then click the “**Web**” button to launch the browser program and connect to the web server.
2. Enter the password in the Login password field (**the default password is “Admin”**), and then click the “**Submit**” button to display the configuration page.

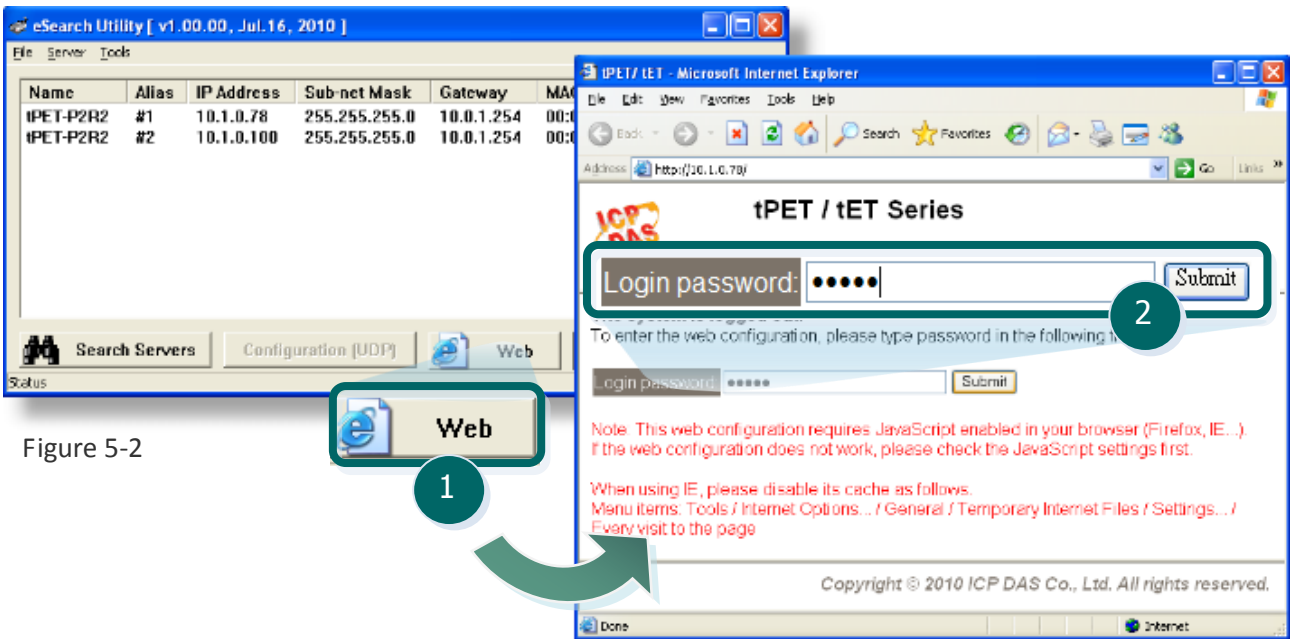

Figure 5-2

- Click the **“Pair Connection”** tab to display the Pair Connection settings page.

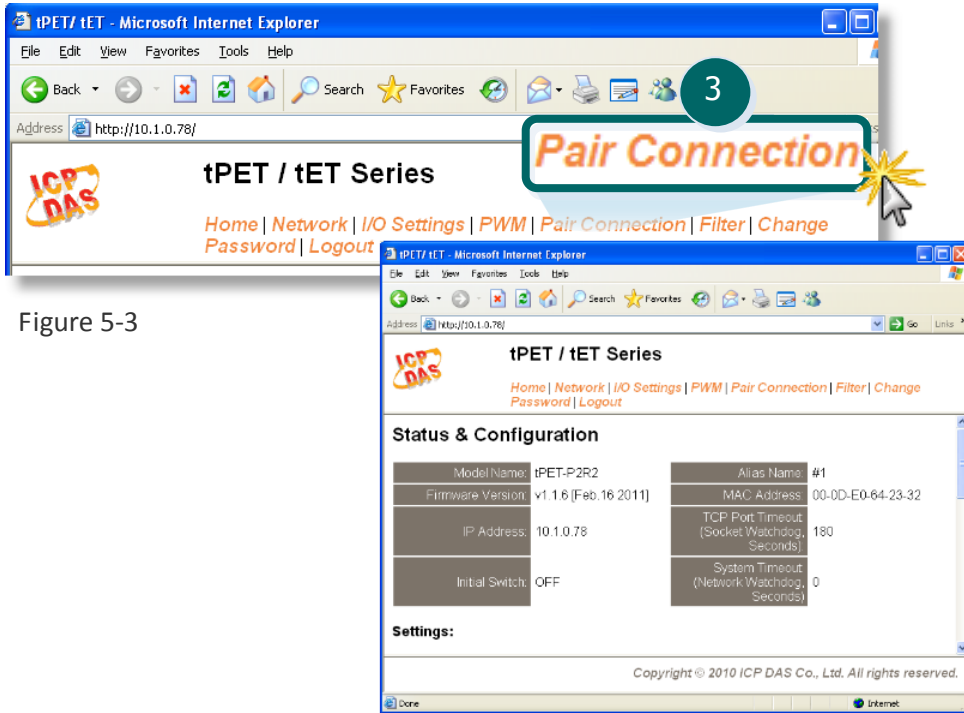

Figure 5-3

- In the I/O Pair connection section, select **“Client”** from the **“Server Mode”** drop-down options.
- Enter the **IP address for PETL/tET/tPET module #2** in the **“Remote Server IP”** field.
- Enter the **TCP Port for PETL/tET/tPET module #2** in the **“Remote TCP Port”** field.

Settings:

The following options are used on client-mode, ignored on server-mode.

I/O Pair-Connection	Current	Updated
Server Mode:	Server	Client (Server=Slave, Client=Master)
Remote Server IP:	Disabled	10 . 1 . 0 . 100
Remote TCP Port:	Disabled	502 (Default: 502)
Connection Timeout:	5	5 (Default: 5 s)
Remote Net ID:	1	1 (Default: 1)
Scan Time:	1000	1000 (Default: 1000 ms)

Figure 5-4

7. Enter a **DI Count Value for PETL/tET/tPET module #2** in the “**Remote DI Count**” field of the “Remote DI to Local DO” section.

The following is an example of a **Polling mode** configuration:

Enter “2” in the “Remote DI Count” field. This means **DI x2 of PETL/tET/tPET module #2** is mapped to **DO x2 of PETL/tET/tPET module #1**.

8. Enter a **DI Count value for PETL/tET/tPET module #1** in the “**Local DI Count**” field of the “Local DI to Remote DO section”.

The following is an example of a **Push mode** configuration:

Enter “2” in the “Local DI Count” field. This means **DI x2 of PETL/tET/tPET module #1** is mapped to **DO x2 of PETL/tET/tPET module #2**.

9. Click the “**Submit**” button to complete the configuration.

Remote DI to Local DO		Current	Updated (Polling in Client Mode)
Remote DI Count:	0	2 (Disable: 0)	7 Polling Mode Configuration
Remote DI Address:	0	0 (Default: 0)	
Local DO Address:	0	0 (Default: 0)	
Local DI to Remote DO		Current	Updated (Push in Client Mode)
Modbus Protocol:	TCP	TCP	8 Push Mode Configuration
Local DI Count:	0	2 (Disable: 0)	
Local DI Address:	0	0 (Default: 0)	
Remote DO Address:	0	0 (Default: 0)	
Force Update Time:	30	30 (Default: 30 s)	

9 Submit

Figure 5-5

5.2 Two Modules Pushing the Local DI to each other (1-to-1, Push mode)

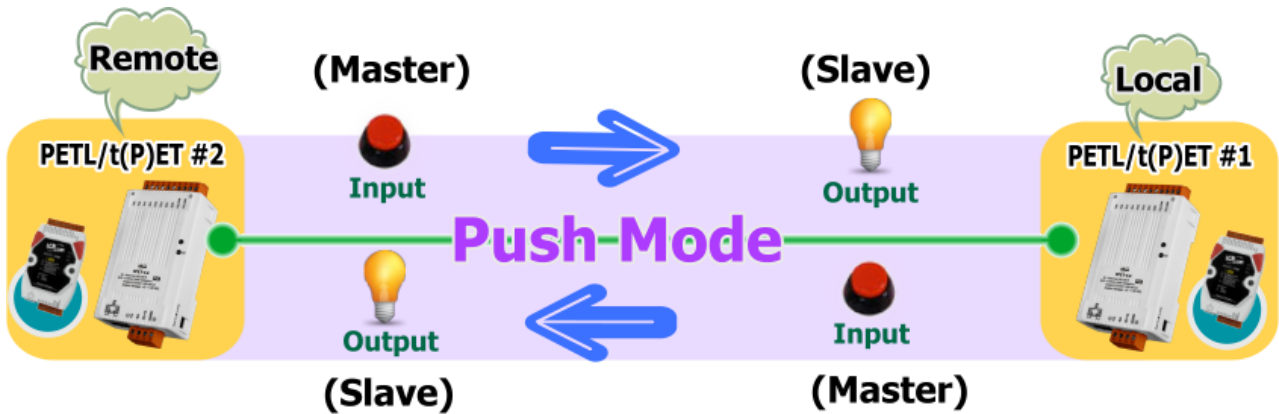

Step 1: Configure the I/O Pair Connection on PETL/tET/tPET module #1

1. In the eSearch Utility, select **PETL/tET/tPET module #1**, and then click the “**Web**” button to launch the browser program and connect to the web server.
2. Enter the password in the Login password field (**the default password is “Admin”**), and then click the “**Submit**” button to display the configuration page.
3. Click the “**Pair Connection**” tab to display the Pair Connection settings page.
4. In the I/O Pair Connection section, select “**Client**” from the “**Server Mode**” drop-down options.
5. Enter the **IP address for PETL/tET/tPET module #2** in the “**Remote Server IP**” field.
6. Enter the **TCP Port for PETL/tET/tPET module #2** in the “**Remote TCP Port**” field.

Refer to [Figures 5-2 to 5-4](#) for illustrations of how to perform the above procedure.

7. Enter a **DI Count value for PETL/tET/tPET module #1** in the “**Local DI Count**” field of the “Local DI to Remote DO” section.

For example, enter “**1**” in the “**Local DI Count**” field. This means **DI x1 of PETL/tET/tPET module #1** is mapped to **DO x1 of PETL/tET/tPET module #2**.

8. Click the “**Submit**” button to complete the configuration.

Remote DI to Local DO	Current	Updated (Polling in Client Mode)
Remote DI Count:	0	<input type="text" value="0"/> (Disable: 0)
Remote DI Address:	0	<input type="text" value="0"/> (Default: 0)
Local DO Address:	0	<input type="text" value="0"/> (Default: 0)
Local DI to Remote DO	Current	Updated (Push in Client Mode)
Modbus Protocol:	TCP	TCP <input type="button" value="v"/>
Local DI Count:	0	<input type="text" value="1"/> (Disable: 0)
Local DI Address:	0	<input type="text" value="0"/> (Default: 0)
Remote DO Address:	0	<input type="text" value="0"/> (Default: 0)
Force Update Time:	30	<input type="text" value="30"/> (Default: 30 s)

7
8

Figure 5-6

Step 2: Configuring I/O Pair-Connection on PETL/t(P)ET#2

1. Select your **PETL/t(P)ET #2** and click **“Web”** button on the eSearch Utility to launch the browser program for connecting to the web server.
2. Enter the password (**default: Admin**) in the Login password field, and then click the **“Submit”** button to enter the configuration page.
3. Click the **“Pair Connection”** link to enter the settings page.
4. Select the **“Client”** option from the **“Server Mode”** drop down options.
5. Type the **IP address of the PETL/t(P)ET #1** in **“Remote Server IP”** field.
6. Type the **TCP Port of the PETL/t(P)ET #1** in **“Remote TCP Port”** field.

Refer to [Figures 5-2 to 5-4](#) for illustrations of how to perform the above steps.

7. Type a **DI Count number for the PETL/t(P)ET #2** in the **“Local DI Count”** field.
 For example, we set **“1”** in the **“Local DI Count”** field. This means the **DI x1 of PETL/t(P)ET #2** are mapped to **DO x1 of PETL/t(P)ET #1**, refer to [Figure 5-8](#) for illustrations.
8. Click the **“Submit”** button to complete the configuration.

5.3 Several Modules Polling the Remote DI (M-to-1, Polling Mode)

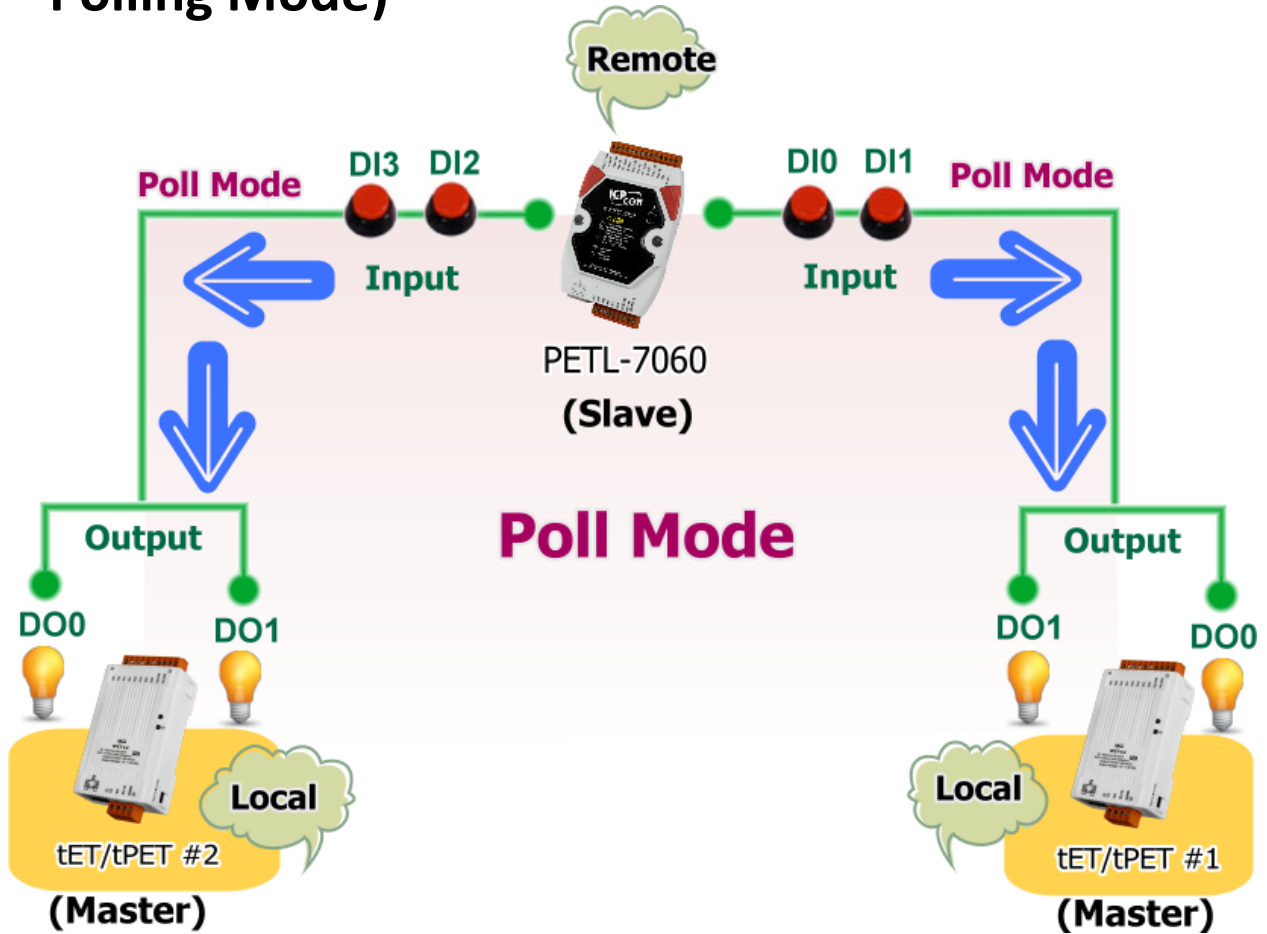

Step 1: Configure the I/O Pair connection on tET/tPET module #1

1. Configure the Ethernet settings for tET/tPET module #1, tET/tPET module #2 and the PETL-7060 slave device. Refer to [Section 3.4 Using the eSearch Utility to assign a new IP](#) for more details.

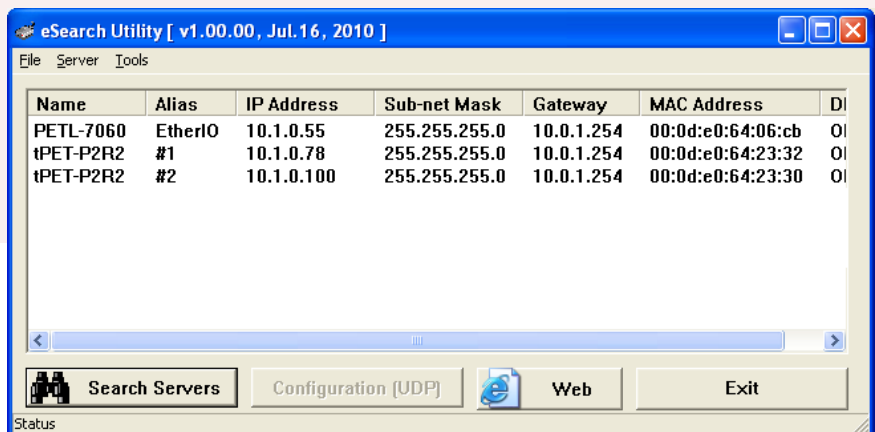

Figure 5-7

2. In the eSearch Utility, select **tET/tPET module #1**, and then click the **“Web”** button to launch the browser program and connect to the web server.
3. Enter the password in the Login password field (**the default password is “Admin”**), and then click the **“Submit”** button to access the configuration page.
4. Click the **“Pair Connection”** tab to display the Pair Connection settings page.

Refer to [Figures 5-2 to 5-3](#) for illustrations of how to perform the above procedure.

Settings:

The following options are used on client-mode, ignored on server-mode.

I/O Pair-Connection	Current	Updated
Server Mode:	Server	Client <input type="button" value="v"/> (Server=Slave, Client=Master)
Remote Server IP:	Disabled	10 . 1 . 0 . 55
Remote TCP Port:	Disabled	502 (Default: 502)
Connection Timeout:	5	5 (Default: 5 s)
Remote Net ID:	1	1 (Default: 1)
Scan Time:	1000	1000 (Default: 1000 ms)

Remote DI to Local DO	Current	Updated (Polling in Client Mode)
Remote DI Count:	1	2 (Disable: 0)
Remote DI Address:	0	0 (Default: 0)
Local DO Address:	0	0 (Default: 0)

Local DI to Remote DO	Current	Updated (Push in Client Mode)
Modbus Protocol:	TCP	TCP <input type="button" value="v"/>
Local DI Count:	0	0 (Disable: 0)
Local DI Address:	0	0 (Default: 0)
Remote DO Address:	0	0 (Default: 0)
Force Update Time:	30	30 (Default: 30 s)

10

Figure 5-8

5. In the I/O Pair Connection section, select “**Client**” from the “**Server Mode**” drop-down options.
6. Enter the **IP address for the PETL-7060 module** in the “**Remote Server IP**” field.
7. Enter the **TCP Port for the PETL-7060 module** in the “**Remote TCP Port**” field.
8. Enter a **DI Count value for the PETL-7060 module** in the “**Remote DI Count**” field of the “Remote DI to Local DO” section.

For example, enter “**2**” in the “**Remote DI Count**” field. This means **DI x2 of the PETL-7060 module** is mapped to **DO x2 of tET/tPET module #1**.

9. Enter the **IP Address for the PETL-7060** in the “**Remote DI Address**” field of the “Remote DI to Local DO” section.

For example, enter “**0**” in the “**Remote DI Address**” field. This means **DI addresses DI0 and DI1 of the PETL-7060 module** are mapped to **DO x2 of tET/tPET module #1**.

Refer to [Figure 5-8](#) for an illustration of how to perform the above procedure.

10. Click the “**Submit**” button to complete the configuration.

Step 2: Configure the I/O Pair Connection on tET/tPET module #2

1. In the eSearch Utility, select **tET/tPET module #2**, and then click “**Web**” button to launch the browser program and connect to the web server.
2. Enter the password in the Login password field (**the default password is “Admin”**), and then click the “**Submit**” button to access the configuration page.
3. Click the “**Pair Connection**” tab to display the Pair connection settings page.

Refer to [Figures 5-2 to 5-3](#) for illustrations of how to perform the above procedure.

Settings:

The following options are used on client-mode, ignored on server-mode.

I/O Pair-Connection	Current	Updated
Server Mode:	Server	Client (Server=Slave, Client=Master)
Remote Server IP:	Disabled	10 . 1 . 0 . 55
Remote TCP Port:	Disabled	502 (Default: 502)
Connection Timeout:	5	5 (Default: 5 s)
Remote Net ID:	1	1 (Default: 1)
Scan Time:	1000	1000 (Default: 1000 ms)

Remote DI to Local DO	Current	Updated (Polling in Client Mode)
Remote DI Count:	1	2 (Disable: 0)
Remote DI Address:	0	2 (Default: 0)
Local DO Address:	0	0 (Default: 0)

Local DI to Remote DO	Current	Updated (Push in Client Mode)
Modbus Protocol:	TCP	TCP
Local DI Count:	0	0 (Disable: 0)
Local DI Address:	0	0 (Default: 0)
Remote DO Address:	0	0 (Default: 0)
Force Update Time:	30	30 (Default: 30 s)

9

Figure 5-9

4. In the I/O Pair connection section, select “**Client**” from the “**Server Mode**” drop-down options.
 5. Enter the **IP address for the PETL-7060 module** in the “**Remote Server IP**” field.
 6. Enter the **TCP Port for the PETL-7060 module** in the “**Remote TCP Port**” field.
 7. Enter a **DI Count value for the PETL-7060 module** in the “**Remote DI Count**” field of the “Remote DI to Local DO section”.
- For example, enter “2” in the “**Remote DI Count**” field. This means **DI x2 of the PETL-7060 module** is mapped to **DO x2 of tET/tPET module #2**.
8. Enter the **DI Address for the PETL-7060 module** in the “**Remote DI Address**” field of the “Remote DI to Local DO section”.
- For example, enter “2” in the “**Remote DI Address**” field. This means **DI addresses DI2 and DI3 of the PETL-7060 module** are mapped to **DO x2 of tET/tPET module #2**.
- Refer to [Figure 5-9](#) for an illustration of how to perform the above procedure.
9. Click the “**Submit**” button to complete the configuration.

5.4 Several Modules Pushing the Local DI (M-to-1, Push Mode)

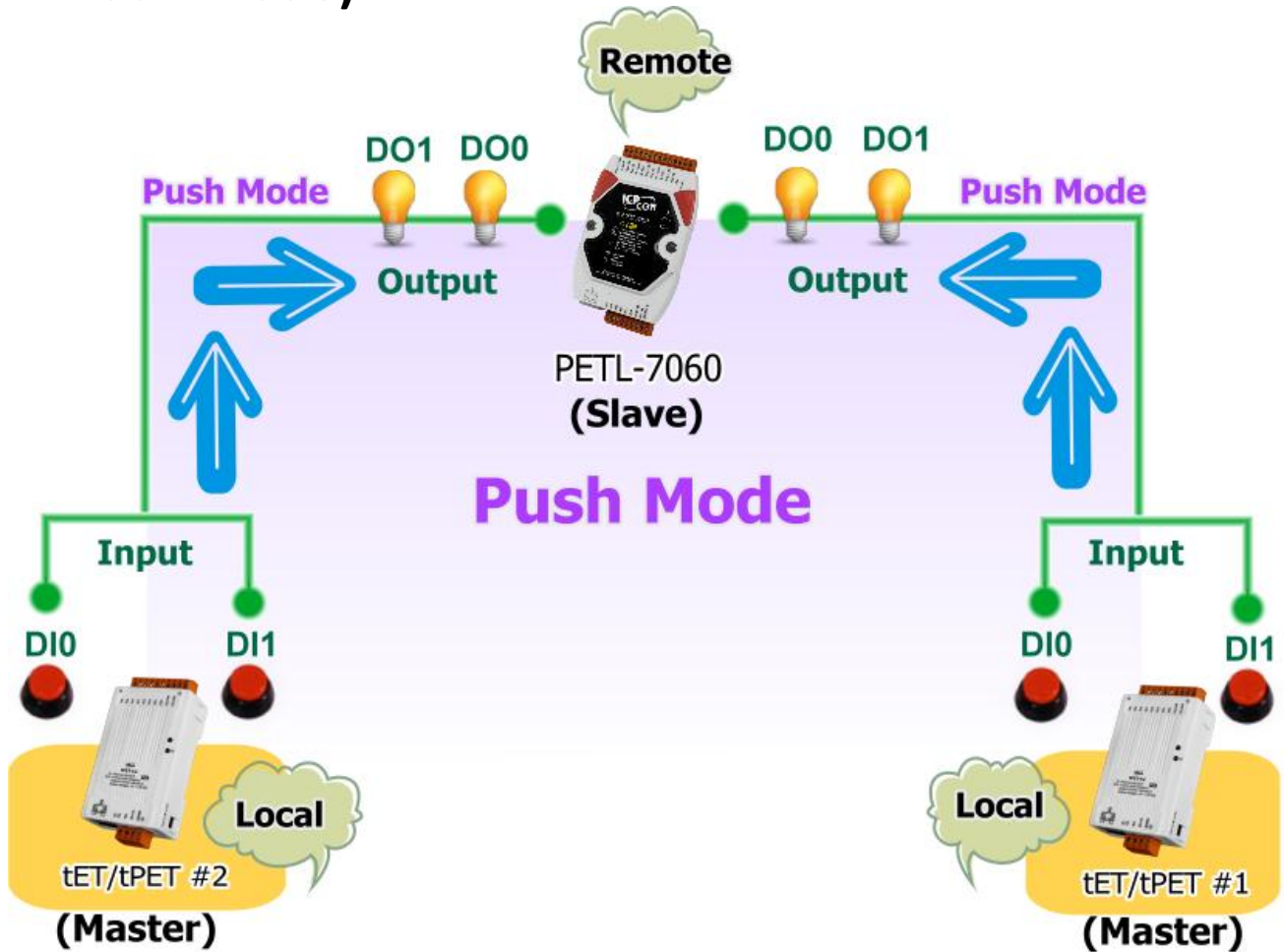

Step 1: Configure the I/O Pair Connection on tET/tPET module #1

1. Configure the Ethernet settings for tET/tPET module #1, tET/tPET module #2 and the PETL-7060 slave device. Refer to [Section 3.4 Using the eSearch Utility to assign a new IP](#) for more details.

eSearch Utility [v1.00.00, Jul.16, 2010]

Name	Alias	IP Address	Sub-net Mask	Gateway	MAC Address	DI
PETL-7060	EtherIO	10.1.0.55	255.255.255.0	10.0.1.254	00:0d:e0:64:06:cb	OI
tPET-P2R2	#1	10.1.0.78	255.255.255.0	10.0.1.254	00:0d:e0:64:23:32	OI
tPET-P2R2	#2	10.1.0.100	255.255.255.0	10.0.1.254	00:0d:e0:64:23:30	OI

Buttons: Search Servers, Configuration [UDP], Web, Exit

Figure 5-10

2. In the eSearch Utility, select **tET/tPET module #1**, and then click the **“Web”** button to launch the browser program and connecting to the web server.
3. Enter the password in the Login password field (**the default password is “Admin”**), and then click the **“Submit”** button to access the configuration page.
4. Click the **“Pair Connection”** tab to display the Pair Connection settings page.

Refer to [Figures 5-2 to 5-3](#) for illustrations of how to perform the above procedure.

Settings:

The following options are used on client-mode, ignored on server-mode.

I/O Pair-Connection	Current	Updated
Server Mode:	Server	Client <input type="button" value="v"/> (Server=Slave, Client=Master)
Remote Server IP:	Disabled	10 . 1 . 0 . 55
Remote TCP Port:	Disabled	502 (Default: 502)
Connection Timeout:	5	5 (Default: 5 s)
Remote Net ID:	1	1 (Default: 1)
Scan Time:	1000	1000 (Default: 1000 ms)

Remote DI to Local DO	Current	Updated (Polling in Client Mode)
Remote DI Count:	0	0 (Disable: 0)
Remote DI Address:	0	0 (Default: 0)
Local DO Address:	0	0 (Default: 0)

Local DI to Remote DO	Current	Updated (Push in Client Mode)
Modbus Protocol:	TCP	TCP <input type="button" value="v"/>
Local DI Count:	0	2 (Disable: 0)
Local DI Address:	0	0 (Default: 0)
Remote DO Address:	0	0 (Default: 0)
Force Update Time:	30	30 (Default: 30 s)

Figure 5-11

5. In the I/O Pair Connection section, select “**Client**” from the “**Server Mode**” drop-down options.
6. Enter the **IP address for the PETL-7060 module** in the “**Remote Server IP**” field.
7. Enter the **TCP Port for the PETL-7060 module** in “**Remote TCP Port**” field.
8. Enter a **DI Count value for tET/tPET module #1** in the “**Local DI Count**” field of the “Local DI to Remote DO section”.

For example, enter “**2**” in the “**Local DI Count**” field. This means **DI x2 of tET/tPET module #1** is mapped to **DO x2 of the PETL-7060 module**.

9. Enter the **DO Address for the PETL-7060 module** in the “**Remote DO Address**” field of the “Local DI to Remote DO” section.

For example, enter “**0**” in the “**Remote DO Address**” field. This means **DO addresses DO0 and DO1 of the PETL-7060 module** are mapped to **DI x2 of tET/tPET module #1**.

Refer to [Figure 5-11](#) for an illustration of how to perform the above procedure.

10. Click the “**Submit**” button to complete the configuration.

Step 2: Configure the I/O Pair Connection on tET/tPET module #2

1. In the eSearch Utility, select **tET/tPET module #2**, and then click the “**Web**” button to launch the browser program and connect to the web server.
2. Enter the password in the Login password field (**the default password is “Admin”**), and then click the “**Submit**” button to access the configuration page.
3. Click the “**Pair Connection**” tab to display the Pair Connection settings page.

Refer to [Figures 5-2 to 5-3](#) for illustrations of how to perform the above procedure.

Settings:

The following options are used on client-mode, ignored on server-mode.

I/O Pair-Connection	Current	Updated
Server Mode:	Server	Client (Server=Slave, Client=Master)
Remote Server IP:	Disabled	10 . 1 . 0 . 55
Remote TCP Port:	Disabled	502 (Default: 502)
Connection Timeout:	5	5 (Default: 5 s)
Remote Net ID:	1	1 (Default: 1)
Scan Time:	1000	1000 (Default: 1000 ms)

Remote DI to Local DO	Current	Updated (Polling in Client Mode)
Remote DI Count:	0	0 (Disable: 0)
Remote DI Address:	0	0 (Default: 0)
Local DO Address:	0	0 (Default: 0)

Local DI to Remote DO	Current	Updated (Push in Client Mode)
Modbus Protocol:	TCP	TCP
Local DI Count:	2	2 (Disable: 0)
Local DI Address:	0	0 (Default: 0)
Remote DO Address:	0	2 (Default: 0)
Force Update Time:	30	30 (Default: 30 s)

Figure 5-12

4. In the I/O Pair Connection section, select “**Client**” from the “**Server Mode**” drop-down options.
 5. Enter the **IP address for the PETL-7060 module** in the “**Remote Server IP**” field.
 6. Enter the **TCP Port for the PETL-7060 module** in the “**Remote TCP Port**” field.
 7. Enter a **DI Count value for tET/tPET module #2** in the “**Local DI Count**” field of the “Local DI to Remoter DO” section.

 For example, enter “**2**” in the “**Local DI Count**” field. This means **DI x2 of tET/tPET module #2** is mapped to **DO x2 of the PETL-7060 module**.
 8. Enter a **DO Address for the PETL-7060 module** in the “**Remote DO Address**” field of the “Local DI to Remote DO” section.

 For example, enter “**2**” in the “**Remote DO Address**” field. This means **DO addresses DO2 and DO3 of the PETL-7060 module** are mapped to **DI x2 of tET/tPET module #2**.
- Refer to Figure 5-12 for an illustration of how to perform the above procedure.**
9. Click the “**Submit**” button to complete the configuration.

6. Modbus Information

The PETL/tET/tPET series is a family of IP-based Modbus I/O devices that allow you to remotely control DI/DO terminals via an Ethernet connection and uses a master-slave communication technique in which only one device (the master) can initiate a transaction (called queries), while other devices (slaves) respond by either supplying the requested data to the master, or by taking the action requested in the query.

Most SCADA (Supervisory Control and Data Acquisition) and HMI software, such as Citect (Schneider Electric), ICONICS, iFIX, InduSoft, Intouch, Entivity Studio, Entivity Live, Entivity VLC, Trace Mode, Wizcon (EIUTIONS), and Wonderware, etc. can be used to easily integrate serial devices via the Modbus protocol.

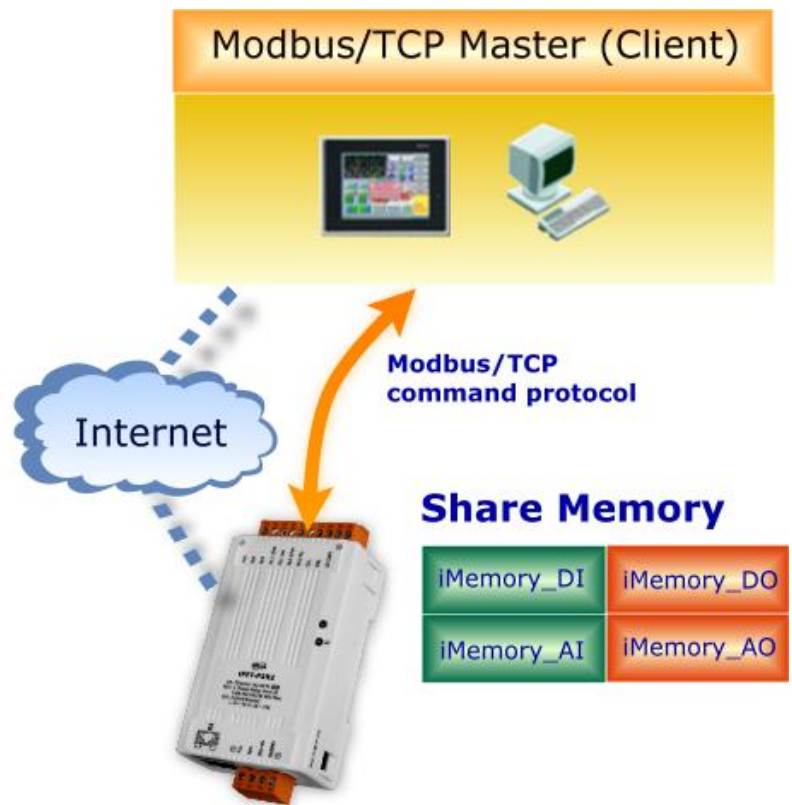

Modbus/TCP master applications can also be developed using any programming language, such as VB, C# and so on.

ICP DAS provides the Modbus SDK that allows development of Modbus applications on a PC.

The relevant demo programs and SDK can be obtained from the following locations:

VB Demo : http://ftp.icpdas.com/pub/cd/6000cd/napdos/et7000/demo/pc_client/

.Net demo and SDK : <http://ftp.icpdas.com/pub/cd/8000cd/napdos/modbus/nmodbus/>

6.1 What is Modbus TCP/IP?

Modbus is a communication protocol that was developed by Modicon Inc. in 1979, and was originally designed for use with Modicon controllers. Detailed information regarding the Modbus protocol can be found at: <http://www.modbus.org>.

The different versions of the Modbus protocol used today include Modbus RTU, which is based on serial communication interfaces such as RS-485 and RS-232, Modbus ASCII and Modbus TCP, which uses the Modbus RTU protocol embedded into TCP packets.

Modbus TCP is an internet protocol. The protocol embeds a Modbus frame into a TCP frame so that a connection oriented approach is obtained, thereby making it more reliable. The master queries the slave and the slave responds with a reply. The protocol is open and, hence, highly scalable.

6.2 Modbus Message Structure

Modbus devices communicate using a master-slave (client-server) technique in which only one device (the master/client) can initiate transactions (called queries). The other devices (slaves/servers) respond by either supplying the requested data to the master, or by taking the action requested in the query.

A query from a master will consist of a slave address (or broadcast address), a function code defining the requested action, any required data, and an error checking field. A response from a slave consists of fields confirming the action taken, any data to be returned, and an error checking field.

■ The Modbus/TCP Message Structure

Bytes 00 - 05	Bytes 06 - 11
6-byte header	RTU Data

■ The Leading 6 bytes of a Modbus/TCP Protocol Query

Byte 00	Byte 01	Byte 02	Byte 03	Byte 04	Byte 05
Transaction identifier		Protocol identifier		Length Field (upper byte)	Length Field (lower byte)

Transaction identifier = Assigned by the Modbus/TCP master (client)

Protocol identifier = 0

Length field (upper byte) = 0 (since all messages are smaller than 256)

Length field (lower byte) = The number of following RTU data bytes

■ RTU Data Structure

Byte 06	Byte 07	Bytes 08 - 09	Bytes 10 - 11
Net ID (Station Number)	Function Code	Data Field	
		Reference Number (Address Mapping)	Number of Points

Net ID specifies the address of the receiver (Modbus/TCP slave).

Function Code specifies the message type.

Data Field is the data block.

Net ID (Station Number)

The first byte in the frame structure of a Modbus RTU query is the receiver's address. A valid address is in the range of 0 to 247. Address 0 is used for general broadcast, while addresses 1 to 247 are given to individual Modbus devices.

Function Code

The second byte in the frame structure of a Modbus RTU query is the function code, which describes what the slave device is required to do. Valid function codes are between 1 and 255. To answer the query, the slave device uses the same function code as contained in the request. The highest bit of the function code will only be set to '1' if an error occurs in the system. In this way, the master will know whether the message has been transmitted correctly or not.

Section	Code	Function	Reference (Address)
6.2.1	01 (0x01)	Read the Status of the Coils (Readback DOs)	0xxxx
6.2.2	02 (0x02)	Read the Status of the Input (Reads DIs)	1xxxx
6.2.3	03 (0x03)	Read the Holding Registers (Readback AOs)	4xxxx
6.2.4	04 (0x04)	Read the Input Registers (Reads AIs)	3xxxx
6.2.5	05 (0x05)	Force a Single Coil (Writes DO)	0xxxx
6.2.6	06 (0x06)	Preset a Single Register (Writes AO)	4xxxx
6.2.7	15 (0x0F)	Force Multiple Coils (Writes DOs)	0xxxx
6.2.8	16 (0x10)	Preset Multiple Registers (Writes AOs)	4xxxx

Data

Data is transmitted in 8-, 16- and 32-bit format. The data for 16-bit registers is transmitted in high-byte first format. For example: 0x0A0B ==> 0x0A, 0x0B. The data for 32-bit registers is transmitted as two 16-bit registers, and is low-word first. For example: 0x0A0B0C0D ==> 0x0C, 0x0D, 0x0A, 0x0B.

6.2.1 01 (0x01) Read the Status of the Coils (Readback DOs)

This function code is used to read either the current status of the coils or the current digital output readback value from the PETL/tET/tPET module.

[Request]

Byte	Description	Size	Value
00	Net ID (Station Number)	1 Byte	1 to 247
01	Function Code	1 Byte	0x01
02-03	Starting DO Address	2 Bytes	Refer to the Modbus Address Table for the PETL/tET/tPET series. (Section 6.3 Modbus Register Table) Byte 02 = high byte Byte 03 = low byte
04-05	Number of Points (Channels)	2 Bytes	Byte 04 = high byte Byte 05 = low byte

[Response]

Byte	Description	Size	Value
00	Net ID (Station Number)	1 Byte	1 to 247
01	Function Code	1 Byte	0x01
02	Byte Count	1 Byte	Byte Count of the Response ($n = (\text{Points}+7)/8$)
03	Data	n Bytes	n= 1; Byte 03 = data bit 7 to 0 n= 2; Byte 04 = data bit 15 to 8 n= m; Byte m+2 = data bit (8m-1) to 8(m-1)

[Error Response]

Byte	Description	Size	Value
00	Net ID (Station Number)	1 Byte	1 to 247
01	Function Code	1 Byte	0x81
02	Exception Code	1 Byte	Refer to the Modbus Standard Specifications for more details

Example: Function 01 (0x01), Readback DOs

	[Leading 6 bytes]	[Request]
Command:	<u>01 02 00 00 00 06</u>	<u>01 01 00 00 00 02</u>
	[Leading 6 bytes]	[Response]
Response:	<u>01 02 00 00 00 04</u>	<u>01 01 01 03</u>
Reads the digital output value		

A description of the command and response is as follows:

Command:	[Leading 6 bytes]	
	Bytes 00-03	01 02 00 00 (Message Number)
	Bytes 04-05	00 06 (Number of bytes remaining in this frame)
	[Request]	
	Byte 00	01 (Net ID)
	Byte 01	01 (Function Code)
	Byte 02-03	00 00 (Starting DO Address)
	Byte 04-05	00 02 (Number of Points)

Response:	[Leading 6 bytes]	
	Bytes 00-03	01 02 00 00 (Message Number)
	Bytes 04-05	00 04 (Number of bytes remaining in this frame)
	[Response]	
	Byte 00	01 (Net ID)
	Byte 01	01 (Function Code)
	Byte 02	01 (Byte Count of the Response)
	Byte 03	03 (Value for DO1 to DO0)

6.2.2 02 (0x02) Read the Status of the Input (Read DIs)

This function code is used to read the current digital input value from the PETL/tET/tPETL module.

[Request]

Byte	Description	Size	Value
00	Net ID (Station Number)	1 Byte	1 to 247
01	Function Code	1 Byte	0x02
02-03	Starting DI Address	2 Bytes	Refer to the Modbus Address Table for the PETL/tET/tPET series. (Section 6.3 Modbus Register Table) Byte 02 = high byte Byte 03 = low byte
04-05	Number of Points (Channels)	2 Bytes	Byte 04 = high byte Byte 05 = low byte

[Response]

Byte	Description	Size	Value
00	Net ID (Station Number)	1 Byte	1 to 247
01	Function Code	1 Byte	0x02
02	Byte Count	1 Byte	Byte Count of Response ($n = (\text{Points} + 7) / 8$)
03	Data	n Bytes	n= 1; Byte 03 = data bit 7 to 0 n= 2; Byte 04 = data bit 15 to 8 n= m; Byte m+2 = data bit (8m-1) to 8(m-1)

[Error Response]

Byte	Description	Size	Value
00	Net ID (Station Number)	1 Byte	1 to 247
01	Function Code	1 Byte	0x82
02	Exception Code	1 Byte	Refer to the Modbus Standard Specifications for more details

Example: Function 02 (0x02), Read DIs

	[Leading 6 bytes]	[Request]
Command:	<u>01 02 00 00 00 06</u>	<u>01 02 00 00 00 02</u>
	[Leading 6 bytes]	[Response]
Response:	<u>01 02 00 00 00 04</u>	<u>01 02 01 03</u>
Reads the digital input value		

A description of the command and response is as follows:

Command:	[Leading 6 bytes]	
	Bytes 00-03	01 02 00 00 (Message Number)
	Bytes 04-05	00 06 (Number of bytes remaining in this frame)
	[Request]	
	Byte 00	01 (Net ID)
	Byte 01	02 (Function Code)
	Bytes 02-03	00 00 (Starting DI Address)
	Bytes 04-05	00 02 (Number of Points)

Response:	[Leading 6 bytes]	
	Bytes 00-03	01 02 00 00 (Message Number)
	Bytes 04-05	00 04 (Number of bytes remaining in this frame)
	[Response]	
	Byte 00	01 (Net ID)
	Byte 01	02 (Function Code)
	Byte 02	01 (Byte Count of the Response)
	Byte 03	03 (Value for DI1 to DI0)

6.2.3 03 (0x03) Read the Holding Registers (Readback AOs)

This function code is used to readback either the current values in the holding registers or the analog output value from the PETL/tET/tPET module. These registers are also used to store the preset values for the digital counter, the host watchdog timer, the module name and the TCP timeout, etc.

[Request]

Byte	Description	Size	Value
00	Net ID (Station Number)	1 Byte	1 to 247
01	Function Code	1 Byte	0x03
02-03	Starting AO Address	2 Bytes	Refer to the Modbus Address Table for the PETL/tET/tPET series . (Section 6.3 Modbus Register Table) Byte 02 = high byte Byte 03 = low byte
04-05	Number of 16-bit Registers (Channels)	2 Bytes	Word Count Byte 04 = high byte Byte 05 = low byte

[Response]

Byte	Description	Size	Value
00	Net ID (Station Number)	1 Byte	1 to 247
01	Function Code	1 Byte	0x03
02	Byte Count	1 Byte	Byte Count of the Response (n=Points x 2 Bytes)
03~	Register Values	n Bytes	Register Values n= 2; Byte 03 = high byte Byte 04 = low byte n= m; Byte 03 = high byte Byte 04 = low byte Byte m+1 = high byte Byte m+2 = low byte

[Error Response]

Byte	Description	Size	Value
00	Net ID (Station Number)	1 Byte	1 to 247
01	Function Code	1 Byte	0x83
02	Exception Code	1 Byte	Refer to the Modbus Standard Specifications for more details

Example: Function 03 (0x03), Read AOs

	[Leading 6 bytes]	[Request]
Command:	<u>01 02 00 00 00 06</u>	<u>01 03 01 03 00 02</u>
	[Leading 6 bytes]	[Response]
Response:	<u>01 02 00 00 00 07</u>	<u>01 03 04 50 32 41 32</u>

Reads the name of the module for the tPET-P2A2

A description of the command and response is as follows:

Command:	[Leading 6 bytes]	
Bytes 00-03		01 02 00 00 (Message Number)
Bytes 04-05		00 06 (Number of bytes remaining in this frame)
	[Request]	
Byte 00		01 (Net ID)
Byte 01		03 (Function Code)
Bytes 02-03		01 03 (Starting AO Address)
Bytes 04-05		00 02 (Number of Points)

Response:	[Leading 6 bytes]	
Bytes 00-03		01 02 00 00 (Message Number)
Bytes 04-05		00 07 (Number of bytes remaining in this frame)
	[Response]	
Byte 00		01 (Net ID)
Byte 01		03 (Function Code)
Byte 02		04 (Byte Count of the Response)
Bytes 03-04		50 32 (The low word for the module name: The ASCII code "0x50, 0x32" represents the characters "P" and "2")
Byte 05-06		41 32 (The high word for the module name: The ASCII code "0x41, 0x32" represents the characters "A" and "2")

6.2.4 04 (0x04) Read the Input Registers (Read AIs)

This function code is used to read either the input registers or the current analog input value from the PETL/tET/tPET module.

These registers are also used to store the current value for the digital counter, the number of DI channels and the number of DO channels, etc.

[Request]

Byte	Description	Size	Value
00	Net ID (Station Number)	1 Byte	1 to 247
01	Function Code	1 Byte	0x04
02-03	Starting AI Address	2 Bytes	Refer to the Modbus Address Table for the PETL/tET/tPET series. (Section 6.3 Modbus Register Table) Byte 02 = high byte Byte 03 = low byte
04-05	Number of 16-bit Registers (Channels)	2 Bytes	Word Count Byte 04 = high byte Byte 05 = low byte

[Response]

Byte	Description	Size	Value
00	Net ID (Station Number)	1 Byte	1 to 247
01	Function Code	1 Byte	0x04
02	Byte Count	1 Byte	Byte Count of the Response (n=Points x 2 Bytes)
03~	Register Values	n Bytes	Register Values n= 2; Byte 03 = high byte Byte 04 = low byte n= m; Byte 03 = high byte Byte 04 = low byte Byte m+1 = high byte Byte m+2 = low byte

[Error Response]

Byte	Description	Size	Value
00	Net ID (Station Number)	1 Byte	1 to 247
01	Function Code	1 Byte	0x84
02	Exception Code	1 Byte	Refer to the Modbus Standard Specifications for more details.

Example: Function 04 (0x04), Read AIs

	[Leading 6 bytes]	[Request]
Command:	<u>01 02 00 00 00 06</u>	<u>01 04 00 64 00 01</u>
	[Leading 6 bytes]	[Response]
Response:	<u>01 02 00 00 00 05</u>	<u>01 04 02 00 02</u>

Reads the number of the DI channels on the tPET-P2A2

A description of the command and response is as follows:

Command:	[Leading 6 bytes]	
	Bytes 00-03	01 02 00 00 (Message Number)
	Bytes 04-05	00 06 (Number of bytes remaining in this frame)
	[Request]	
	Byte 00	01 (Net ID)
	Byte 01	04 (Function Code)
	Bytes 02-03	00 64 (Starting AI Address)
	Bytes 04-05	00 01 (Number of 16-bit Registers)

Response:	[Leading 6 bytes]	
	Bytes 00-03	01 02 00 00 (Message Number)
	Bytes 04-05	00 05 (Number of bytes remaining in this frame)
	[Response]	
	Byte 00	01 (Net ID)
	Byte 01	04 (Function Code)
	Byte 02	02 (Byte Count of the Response)
	Bytes 03-04	00 02 (Number of DI Channels on the tPET-P2A2)

6.2.5 05 (0x05) Force a Single Coil (Write DO)

This function code is used to set the status of a single coil or a single digital output value for the PETL/tET/tPET module.

[Request]

Byte	Description	Size	Value
00	Net ID (Station Number)	1 Byte	1 to 247
01	Function Code	1 Byte	0x05
02-03	DO Address	2 Bytes	Refer to the Modbus Address Table for the PETL/tET/tPET series. (Section 6.3 Modbus Register Table) Byte 02 = high byte Byte 03 = low byte
04-05	Output Value	2 Bytes	0xFF 00 sets the output to ON. 0x00 00 sets the output to OFF. All other values are invalid and will not affect the coil. Byte 04 = high byte Byte 05 = low byte

[Response]

Byte	Description	Size	Value
00	Net ID (Station Number)	1 Byte	1 to 247
01	Function Code	1 Byte	0x05
02-03	DO Address	2 Bytes	The value is the same as Bytes 02-03 of the Request
04-05	Output Value	2 Bytes	The value is the same as Bytes 04-05 of the Request

[Error Response]

Byte	Description	Size	Value
00	Net ID (Station Number)	1 Byte	1 to 247
01	Function Code	1 Byte	0x85
02	Exception Code	1 Byte	Refer to the Modbus Standard Specifications for more details.

Example: Function 05 (0x05), Write DO

	[Leading 6 bytes]	[Request]
Command:	<u>01 02 00 00 00 06</u>	<u>01 05 00 01 FF 00</u>
	[Leading 6 bytes]	[Response]
Response:	<u>01 02 00 00 00 06</u>	<u>01 05 00 01 FF 00</u>

Sets Channel DO1 to ON

A description of the command and response is as follows:

Command:	[Leading 6 bytes]	
	Bytes 00-03	01 02 00 00 (Message Number)
	Bytes 04-05	00 06 (Number of bytes remaining in this frame)
	[Request]	
	Byte 00	01 (Net ID)
	Byte 01	05 (Function Code)
	Bytes 02-03	00 01 (DO Address)
	Bytes 04-05	FF 00 (Sets the output to ON)

Response:	[Leading 6 bytes]	
	Bytes 00-03	01 02 00 00 (Message number)
	Bytes 04-05	00 06 (Number of bytes remaining in this frame)
	[Response]	
	Byte 00	01 (Net ID)
	Byte 01	05 (Function Code)
	Bytes 02-03	00 01 (DO Address)
	Bytes 04-05	FF 00 (Indicates that the DO has been set to ON)

6.2.6 06 (0x06) Preset a Single Register (Write AO)

This function code is used to set a specific holding register to store the configuration values for the PETL/tET/tPET module.

[Request]

Byte	Description	Size	Value
00	Net ID (Station Number)	1 Byte	1 to 247
01	Function Code	1 Byte	0x06
02-03	AO Address	2 Bytes	Refer to the Modbus Address Table for the PETL/tET/tPET series. (Section 6.3 Modbus Register Table) Byte 02 = high byte Byte 03 = low byte
04-05	Register Value	2 Bytes	Register Value Byte 04 = high byte Byte 05 = low byte

[Response]

Byte	Description	Size	Value
00	Net ID (Station Number)	1 Byte	1 to 247
01	Function Code	1 Byte	0x06
02-03	AO Address	2 Bytes	The value is the same as Bytes 02-03 of the Request
04-05	Register Value	2 Bytes	The value is the same as Bytes 04-05 of the Request

[Error Response]

Byte	Description	Size	Value
00	Net ID (Station Number)	1 Byte	1 to 247
01	Function Code	1 Byte	0x86
02	Exception Code	1 Byte	Refer to the Modbus Standard Specifications for more details.

Example: Function 06 (0x06), Write AO

	[Leading 6 bytes]	[Request]
Command:	<u>01 02 00 00 00 06</u>	<u>01 06 01 08 00 3C</u>
	[Leading 6 bytes]	[Response]
Response:	<u>01 02 00 00 00 06</u>	<u>01 06 01 08 00 3C</u>

Sets the system timeout to 60 seconds

A description of the command and response is as follows:

Command:	[Leading 6 bytes]	
Bytes 00-03		01 02 00 00 (Message Number)
Bytes 04-05		00 06 (Number of bytes remaining in this frame)
	[Request]	
Byte 00		01 (Net ID)
Byte 01		06 (Function Code)
Bytes 02-03		01 08 (AO Address)
Bytes 04-05		00 3C (Sets the system timeout to 60 seconds)

Response:	[Leading 6 bytes]	
Bytes 00-03		01 02 00 00 (Message Number)
Bytes 04-05		00 06 (Number of bytes remaining in this frame)
	[Response]	
Byte 00		01 (Net ID)
Byte 01		06 (Function Code)
Bytes 02-03		01 08 (AO Address)
Bytes 04-05		00 3C (Indicates that the system timeout has been set to 60 seconds)

6.2.7 15 (0x0F) Force Multiple Coils (Write DOs)

This function code is used to set multiple coils status or write multiple digital output values for the PETL/tET/tPET module.

[Request]

Byte	Description	Size	Value
00	Net ID (Station Number)	1 Byte	1 to 247
01	Function Code	1 Byte	0x0F
02-03	Starting DO Address	2 Bytes	Refer to the Modbus Address Table for PETL/tET/tPET series. (Section 6.3 Modbus Register Table) Byte 02 = high byte Byte 03 = low byte
04-05	Number of Output Channels (Points)	2 Bytes	Byte 04 = high byte Byte 05 = low byte
06	Byte count	1 Byte	$n = (\text{Points} + 7) / 8$
07	Output value	n Bytes	A bit corresponds to a channel. A value of 1 for a bit denotes that the channel is ON, while a value of 0 denotes that the channel is OFF. n= 1; Byte 07 = data bit 7 to 0 n= 2; Byte 08 = data bit 15 to 8 n= m; Byte m+6 = data bit (8m-1) to 8 (m-1)

[Response]

Byte	Description	Size	Value
00	Net ID (Station Number)	1 Byte	1 to 247
01	Function Code	1 Byte	0x0F
02-03	Starting DO Address	2 Bytes	The value is the same as Bytes 02-03 of the Request
04-05	Number of Output Channels (Points)	2 Bytes	The value is the same as Bytes 04-05 of the Request

[Error Response]

Byte	Description	Size	Value
00	Net ID (Station Number)	1 Byte	1 to 247
01	Function Code	1 Byte	0x8F
02	Exception Code	1 Byte	Refer to the Modbus Standard Specifications for more details.

Example: Function 15 (0x0F), Write DOs

	[Leading 6 bytes]	[Request]
Command:	<u>01 02 00 00 00 08</u>	<u>01 0F 01 0B 00 02 01 03</u>
	[Leading 6 bytes]	[Response]
Response:	<u>01 02 00 00 00 06</u>	<u>01 0F 01 0B 00 02</u>

Sets the safe value (DO0 – DO1)

A description of the command and response is as follows:

Command:	[Leading 6 bytes]	
	Bytes 00-03	01 02 00 00 (Message Number)
	Bytes 04-05	00 08 (Number of bytes remaining in this frame)
	[Request]	
	Byte 00	01 (Net ID)
	Byte 01	0F (Function Code)
	Bytes 02-03	01 0B (Starting DO Address)
	Bytes 04-05	00 02 (Number of Output Channels)
	Byte 06	01 (Byte Count)
	Byte 07	03 (Output Value)

Response:	[Leading 6 bytes]	
	Bytes 00-03	01 02 00 00 (Message Number)
	Bytes 04-05	00 06 (Number of bytes remaining in this frame)
	[Response]	
	Byte 00	01 (Net ID)
	Byte 01	0F (Function Code)
	Bytes 02-03	01 0B (Starting DO Address)
	Bytes 04-05	00 02 (Number of Input Channels)

6.2.8 16 (0x10) Preset Multiple Registers (Write AOs)

This function code is used to set multiple holding registers that are used to store the configuration values for the PETL/tET/tPET module.

[Request]

Byte	Description	Size	Value
00	Net ID (Station Number)	1 Byte	1 to 247
01	Function Code	1 Byte	0x10
02-03	Starting AO Address	2 Bytes	Refer to the Modbus Address Table for the PETL/tET/tPET series.. (Section 6.3 Modbus Register Table) Byte 02 = high byte Byte 03 = low byte
04-05	Number of 16-bit Registers (Channels)	2 Bytes	Word Count. Byte 04 = high byte Byte 05 = low byte
06	Byte Count	1 Byte	n =Points x 2 Bytes
07	Register Values	n Bytes	Register Values. n= 2; Byte 03 = high byte Byte 04 = low byte n= m; Byte 03 = high byte Byte 04 = low byte Byte m+1 = high byte Byte m+2 = low byte

[Response]

Byte	Description	Size	Value
00	Net ID (Station Number)	1 Byte	1 to 247
01	Function Code	1 Byte	0x10
02-03	Starting AO Address	2 Bytes	The value is the same as Bytes 02-03 of the Request
04-05	Number of 16-bit Registers (Channels)	2 Bytes	The value is the same as Bytes 04-05 of the Request

[Error Response]

Byte	Description	Size	Value
00	Net ID (Station Number)	1 Byte	1 to 247
01	Function Code	1 Byte	0x90
02	Exception Code	1 Byte	Refer to the Modbus Standard Specifications for more details.

Example: Function 16 (0x10), Write AOs

	[Leading 6 bytes]	[Request]
Command:	<u>01 02 00 00 00 0B</u>	<u>01 10 00 32 00 01 02 03 E8 00 00</u>
	[Leading 6 bytes]	[Response]
Response:	<u>01 02 00 00 00 06</u>	<u>01 10 00 32 00 01</u>

Sets the Preset value for the digital counter

A description of the command and response is as follows:

Command:	[Leading 6 bytes]	
	Bytes 00-03	01 02 00 00 (Message Number)
	Bytes 04-05	00 0B (Number of bytes remaining in this frame)
	[Request]	
	Byte 00	01 (Net ID)
	Byte 01	10 (Function Code)
	Bytes 02-03	00 32 (Starting AO Address)
	Bytes 04-05	00 01 (Number of 16-bit Registers)
	Byte 06	02 (Byte Count)
	Bytes 07-10	03 E8 00 00 (Preset Value for the digital counter)

Response:	[Leading 6 bytes]	
	Bytes 00-03	01 02 00 00 (Message Number)
	Bytes 04-05	00 06 (Number of bytes remaining in this frame)
	[Response]	
	Byte 00	01 (Net ID)
	Byte 01	10 (Function Code)
	Bytes 02-03	00 32 (Starting AO address)
	Bytes 04-05	00 01 (Word Count)

Data Field

The data field of messages sent between a master and a slave contains additional information about the action to be taken by the master or any information requested by the slave. If the master does not require this information, the data field can be empty.

Reference (Address)	Description
0xxxx	<p><u>Read/Write Discrete Outputs or Coils.</u></p> <p>A 0x reference address is used to output device data to a digital output channel.</p>
1xxxx	<p><u>Read Discrete Inputs.</u></p> <p>The ON/OFF status of a 1x reference address is controlled by the corresponding digital input channel.</p>
3xxxx	<p><u>Read Input Registers.</u></p> <p>A 3x reference register contains a 16-bit number received from an external source, e.g. an analog signal.</p>
4xxxx	<p><u>Read/Write Output or Holding Registers.</u></p> <p>A 4x register is used to store 16 bits of numerical data (binary or decimal), or to send the data from the CPU to an output channel.</p>

For more details regarding Address Mapping (Reference Number), refer to [Section 6.3 Modbus Register Table.](#)

6.3 Modbus Register Table

Data from 16-bit registers is transmitted in high-byte first order. For example: 0x0A0B ==> 0x0A, 0x0B. Data from 32-bit registers is transmitted as two 16-bit registers, and is in low-word first order. For example: 0x0A0B0C0D ==> 0x0C, 0x0D, 0x0A, 0x0B.

6.3.1 Common Functions

■ 0xxxx: DO Address (Base 0)

Starting Address	Points	Description	Bits per Point	Range	Access Type
127 (0x7F)	1	Restores all default web settings	1	1 = Restore	W (Pulse)
128 (0x80)	1	Default ID Settings	1	1 = Restore	W (Pulse)
133 (0x85)	1	Reboots the PETL/tET/tPET module	1	1 = Reboot	W (Pulse)
Notes	"W": Write				

■ 3xxxx: AI address (Base 0)

Starting Address	Points	Description	Bits per Point	Range	Access Type
151 (0x97)	1	Firmware Version	16	"123" denotes that the version is 1.2.3	R
158 (0x9E)	1	Modbus Communication Status	16	0 = No Error 1 = Timeout	R
160 (0xA0)	1	Pair-Connection Status	16	0 = Normal 1 = Timeout 2 = Disconnected	R
Notes	"R": Read				

■ **4xxxx: AO Address (Base 0)**

Starting Address	Points	Description	Bits per Point	Range	Access Type
255 (0xFF)	1	CPU Reset Status	16	1 = Reset at Power-on 2 = Reset by the WDT 3 = Reset using the reset command	R/W
257 (0x101)	1	Sets the Host Watchdog Timer (WDT)	16	<5: Disabled 5 to 65535 : Enabled (units: seconds) 0: Default If the PETL/tET/tPET module loses communication with the host PC for more than the period defined in the WDT settings, the DO channels will revert to their safe values and the Host WDT Events Counter will be increased by one.	R/W/F
258 (0x102)	1	Host WDT Events	16	Denotes how many Host WDT Events have occurred since the last CPU reset	R/W
259 (0x103)	1	Module Name	16	Module Name	R
263 (0x107)	1	Sets the TCP Timeout Value	16	<5: Disabled 5 to 65535 : Enabled (units: seconds) 0: Default	R/W/F
264 (0x108)	1	Sets the System Timeout Value	16	<30: Disabled 30~65535 : Enabled (unit: second) 0: default	R/W/F
Notes	<p>“R”: Read; “W”: Write; “F”: Setting is recorded in flash as default. Warning: Frequent writing to the Flash can cause it to become corrupt.</p>				

6.3.2 Specific Functions

The nDI and nDO parameters for each PETL/tET/tPET series module used in the following Modbus Address Tables are as follows:

Model Name		Number of DO Channels (nDO)	Number of DI Channels (nDI)
Non-PoE Series	PoE Series		
tET-P6	tPET-P6	0	6
tET-PD6	tPET-PD6	0	6
tET-C4	tPET-C4	4	0
tET-A4	tPET-A4	4	0
tET-P2C2	tPET-P2C2	2	2
tET-P2A2	tPET-P2A2	2	2
tET-P2POR2	tPET-P2POR2	2	2
tET-PD2POR2	tPET-PD2POR2	2	2
tET-P2R2	tPET-P2R2	2	2
tET-PD2R1	tPET-PD2R1	1	2
-	PETL-7060	6	6

■ 0xxxx: DO address (Base 0)

Begin address	Points	Description	Bits per Point	Range	Access Type
0 (0x00)	1 to nDO	Digital Output Channels	1	0 = Off 1 = On	R/W
32 (0x20)	1	Clears the status of all high latched DI Channels	1	1 = Clear	W
33 (0x21)	1	Clears the status of all low latched DI Channels	1	1 = Clear	W
34 (0x22)	1 to nDI	Clears the high speed digital counter for all DI Channels	1	1 = Clear	W
60 (0x3C)	1	Saves specific data to Flash (The access type for some registers is labeled with an "E")	1	1 = Clear	W
100 (0x64)	1 to nDO	Enables the PWM for all DO Channels	1	0 = Off 1 = On (Default= 0)	R/W

150 (0x96)	1	Enables the high and low latches for all DI Channels	1	0 = Disable 1 = Enable (Default= 0)	R/W/F
151 (0x97)	1 to nDI	Enables the high speed digital counter for all DI Channels	1	0 = Disable 1 = Enable (Default= 0)	R/W/F
190 (0xBE)	1 to nDI	Enables frequency measurement for all DI Channels	1	0 = Disable 1 = Enable (Default= 0)	R/W/F
235 (0xEB)	1 to nDO	Sets the Power-on value for all DO Channels	1	0 = Off 1 = On (Default= 0)	R/W/F
267 (0x10B)	1 to 1DO	Sets the Safe value for all DO Channels	1	0 = Off 1 = On (Default= 0)	R/W/F
Notes	<p>“R”: Read “W”: Write “F”: Settings are recorded in flash by default “E”: After writing DO[60] register, the data will be stored in flash. Warning: Frequency writing to the Flash can cause it to become corrupt.</p>				

 **Because of the characteristics of the relay functions, it is recommended that the PWM on t(P)ET-P(D)2POR2/ t(P)ET-P2R2/ t(P)ET-PD2R1/PETL-7060 series (i.e., modules with relay functions) is not used for extended periods of time.**

■ **1xxxx: DI address (Base 0)**

Starting Address	Points	Description	Bits per Point	Range	Access Type
0 (0x00)	1 to nDI	The status of all Digital Input Channels	1	0 = Off 1 = On	R
32 (0x20)	1 to nDI	The status of all high latched DI Channels	1	0 = None 1 = Latched	R
64 (0x40)	1 to nDI	The status of all low latched DI Channels	1	0 = None 1 = Latched	R
Notes	“R”: Read				

■ **3xxxx: AI Address (Base 0)**

Begin address	Points	Description	Bits per Point	Value	Access Type
16 (0x10)	1 to nDI	The Digital Counter Value	32	0 to 4294967296	R
64 (0x40)	1 to nDI	The frequency Value * 1,000. (Note: The Client must first divide the value by 1,000.)	32	0 to 4294967296	R
100 (0x64)	1	Number of DI Channels	16	nDI	R
110 (0x6E)	1	Number of DO Channels	16	nDO	R
121 (0x79)	1	Number of high-speed counters	16	nDI	R
Notes	"R": Read				

 Each 32-bit point occupies two 16-bit registers, and has an address offset of 2, i.e., the second point (channel) is at the starting-address +2, and so on.

■ **4xxxx: AO Address (Base 0)**

Begin address	Points	Description	Bits per Point	Range	Access Type
50 (0x32)	1 to nDI	The preset value for the high speed digital counter	32	0 to 4294967296	R/W/E
100 (0x64)	1 to nDO	The duty cycle for the DO PWM The first word (16-bit register) is the high pulse width, while the second word is the low pulse width. The units are in ms, and the resolution is about 10 ms.	32	0 to 65535; 0 to 65535;	R/W/E
150 (0x96)	1 to nDO	The Scan mode for the DI frequency measurement. Refer to Section 4.3.2 DI/DO Configuration for more details.	16	1000= 1000 ms 100= 100 ms 2000=Single pulse	R/W/F

200 (0x64)	1 to nDO	The moving average of the DI frequency measurement.	16	1=No average 2= Average 2 values 4= Average 4 values 8=Average 8 values	R/W/F
268 (0x10C)	1 to nDO	The Min-Switching Time for all DO Channels	16	1 to 65535 second	R/W/F
284 (0x11C)	1 to nDO	The Auto-off Time for all DO Channels	16	1 to 65535 second	R/W/F
Notes	<p>“R”: Read “W”: Write “F”: Settings are recorded in flash by default “E”: After writing the DO[60] register, the data will be stored in flash. Warning: Frequent writing to the Flash can cause it to become corrupt.</p>				



Each 32-bit point occupies two 16-bit registers, and has an address offset of 2, i.e., the second point (channel) is at the starting begin-address +2, and so on.

7. Related Tools

7.1 LabVIEW

LabVIEW is a system-design platform and development environment and is ideal for acquiring, analyzing, and presenting data. LabVIEW provides a graphical development environment that allows you to drag and drop pre-built objects to quickly create data acquisition, instrumentation and control systems, thereby boosting productivity and reducing development time. LabVIEW makes it possible to quickly create user interfaces that enable interactive control of software systems then specify the functionality of your system, by simply assembling a block diagram, which is a natural design notation for scientists and engineers.

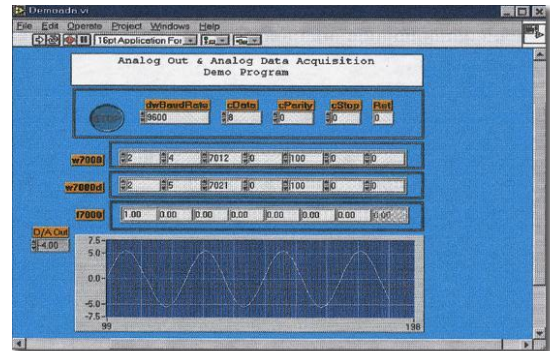

A document that describes how to link LabVIEW to a PETL/tET/tPET device using the Modbus protocol can be found at:

http://ftp.icpdas.com/pub/cd/6000cd/napdos/et7000/document/application/labview/labview_modbus_eng.pdf

7.2 OPC Server

OPC (OLE for Process Control) was the first standard resulting from the collaboration of a number of leading worldwide automation suppliers working in cooperation with Microsoft. Originally based on Microsoft's OLE COM (Component Object Model) and DCOM (Distributed Component Object Model) technologies, the specification defines a standard set of objects, interfaces and methods for use in process control and manufacturing automation applications to facilitate interoperability.

A wide range of different mechanisms are provided by various vendors that allow access to a variety of devices via specific applications. However, if an OPC server is provided for the device, other applications will also be able to access the device via the OPC interface.

7.3 SCADA

SCADA stands for Supervisor Control and Data Acquisition and is a PC-based production automation and control system.

SCADA is widely used in many fields, including power generation, water systems, the oil industry, the chemical, and the automobile industry. Different fields require different functions, but they all have the same common requirements:

- ✓ Graphical interface
- ✓ Process mimicking
- ✓ Real-time and historical trend data
- ✓ Alarm systems
- ✓ Data acquisition and recording
- ✓ Data analysis
- ✓ Report generation

Accessing the PETL/tET/tPET Series Module

SCADA software is able to access PETL/tET/tPET series devices using the Modbus communication protocol without the need for other software drivers.

Popular SCADA Software

Some of the more popular SCADA software includes **Citect, ICONICS, iFIX, InduSoft, Intouch, Entivity Studio, Entivity Live, Entivity VLC, Trace Mode, Wizcon, and Wonderware**, etc.

In the following sections, three popular brands of SCADA software are introduced, together with detailed instructions of how to use them to communicate with PETL/tET/tPET series modules using the Modbus TCP protocol.

■ InduSoft

InduSoft Web Studio is a powerful, integrated collection of automation tools that includes all the building blocks needed to develop modern Human Machine Interfaces (HMI), Supervisory Control and Data Acquisition (SCADA) systems, and embedded instrumentation and control applications. InduSoft Web Studio's application runs in native Windows NT, 2000, XP, CE and CE .NET environments and conforms to industry standards such as Microsoft .NET, OPC, DDE, ODBC, XML, and ActiveX.

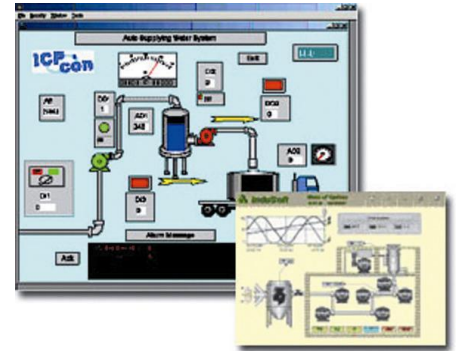

The document describing how to link InduSoft to the PETL/tET/tPET series module using the Modbus protocol is located at:

http://ftp.icpdas.com/pub/cd/6000cd/napdos/et7000/document/application/indusoft/indusoft_modbus_eng.pdf

■ Citect



CitectSCADA is a fully integrated Human Machine Interface (HMI) / SCADA solution that enables users to increase return on assets by delivering a highly scalable, reliable control and monitoring system. Easy-to-use configuration tools and powerful features enable the rapid development and deployment of solutions for applications of any size.

The document describing how to link Citect to the PETL/tET/tPET module using the Modbus protocol is located on

http://ftp.icpdas.com/pub/cd/6000cd/napdos/et7000/document/application/ifix/ifix_mbtcp.pdf

■ iFix



The document describing how to link iFix to the PETL/tET/tPET series module using the Modbus protocol is located at:

http://ftp.icpdas.com/pub/cd/6000cd/napdos/et7000/document/application/citect/citect_mbtcp.pdf

FAQ

A. How do I prevent IE from showing a blank page when configuring the PETL/tET/tPET series module.

Disable the IE cache using the following procedure:

Step 1: In the IE browser, select the “Internet Options...” item from the “Tools” menu.

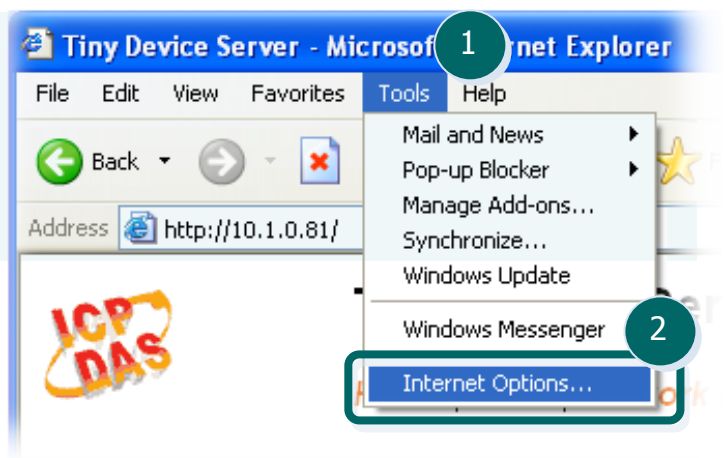

Step 2: Click the “General” tab and then click the “Settings...” button in the Temporary Internet files area of the Internet Options dialog box.

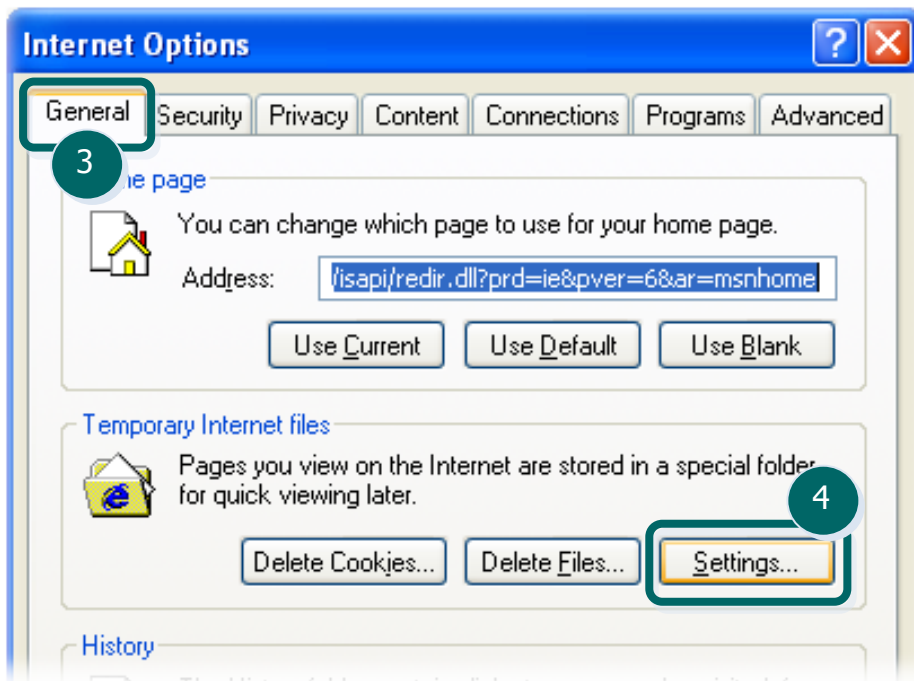

Step 3: Click the “Every visit to the page” option, and then click the “OK” button in both the **Settings** and the **Internet Options** dialog boxes.

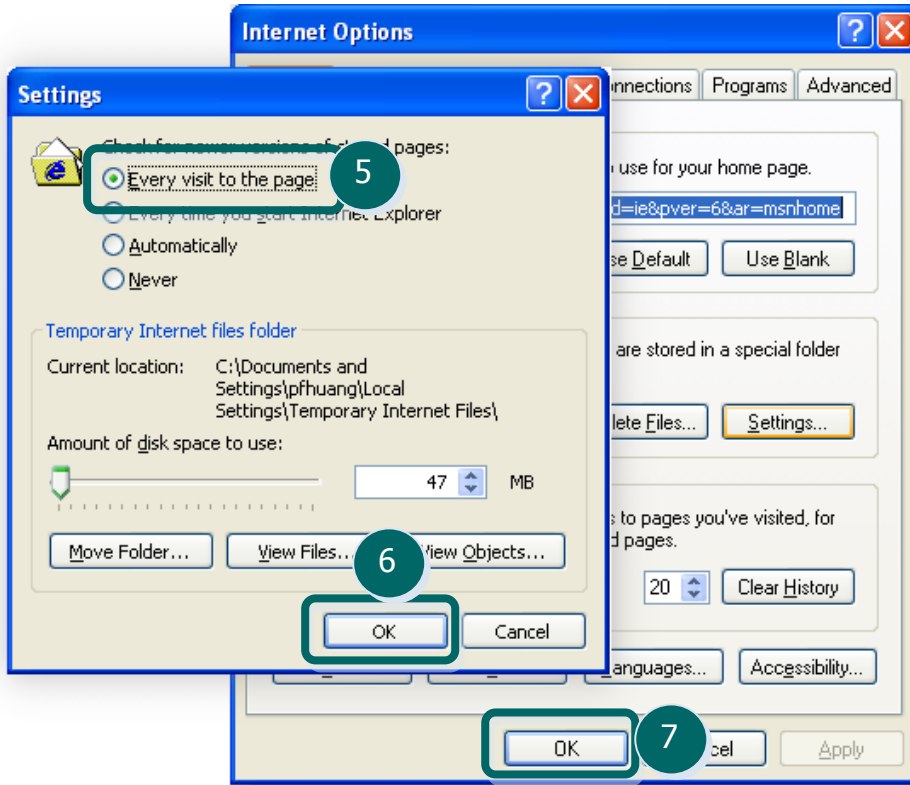

Step 4: Click the “Refresh” button on the browser or press **F5** on your keyboard to refresh the PETL/tET/tPET series web server page, or re-open IE.

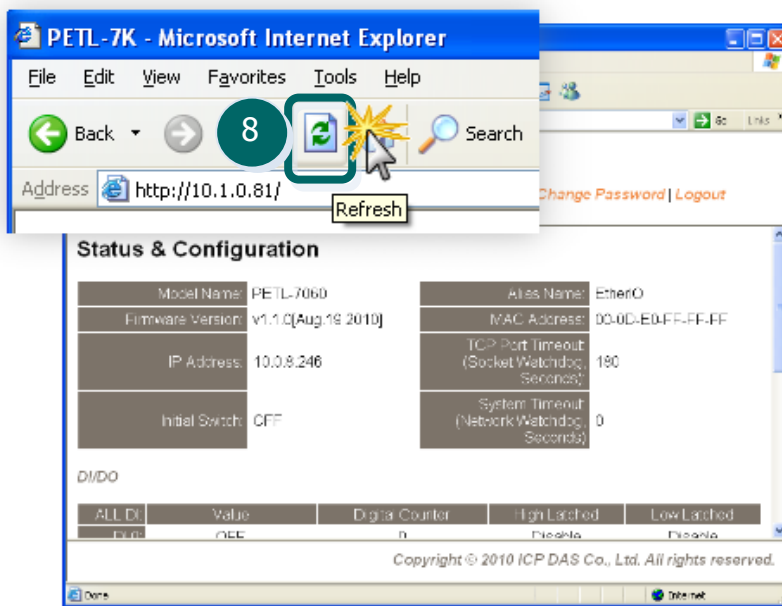

B. How to update the firmware via Ethernet.

If the module is not functioning correctly (e.g. there is no response to a search request, or if the system LED is continuously displayed as either OFF or ON), you should download a copy of the latest image of the firmware from the ICPDAS web site and then update the firmware for the module. For more details, refer to the “tPET_PETL_Series_Firmware_update.pdf” file located at:

CD: \NAPDOS\tPET\Firmware\
or

<http://ftp.icpdas.com/pub/cd/tinymodules/napdos/tpet/firmware/>



C. Why isn't my Host computer able to ping or search for the PETL/tET/tPET series module?

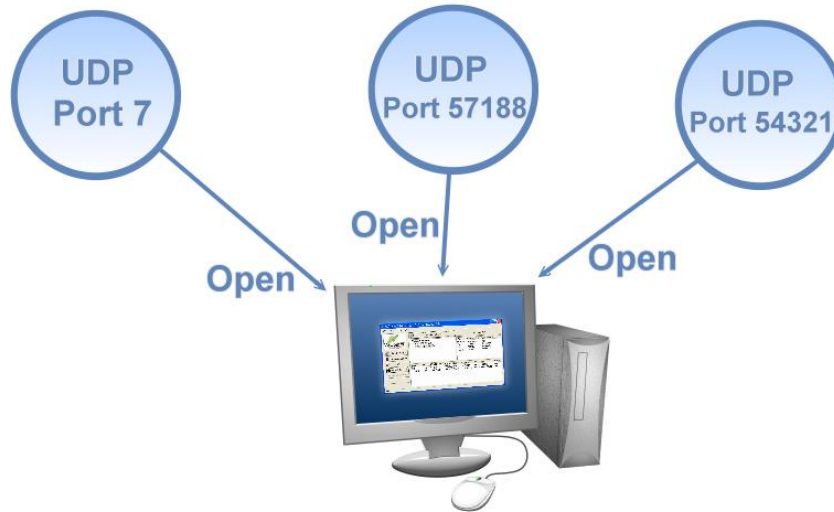

The computer can only establish a connection with the PETL/tET/tPET module through specific ports. Confirm with your network administrator that access to UDP Port 7, Port 57188 and Port 54321 isn't being denied by another network device.

For more detailed information regarding TCP/UDP ports refers to the following tables:

TCP Port:

Port Number	Description
80	HTTP (HyperText Transport Protocol)
502	Modbus Data Port

UDP Port:

Port Number	Description
7	Echo (Ping)
57188	UDP Search Request
54321	UDP Search Response