

PISO-PS300(U)

3 axis stepping/servo control board

User Manual

Version 5.0 01/2012 Edition

Driver update : <http://www.icpdas.com>

Warranty: All products manufactured by ICP DAS are warranted against defective materials for one year from the date of delivery to the original purchaser

Warning: ICP DAS assumes no liability for damage consequent to the use of this product. ICP DAS reserves the right to change this manual at any time without notice. The information furnished by ICP DAS is believed to be accurate and reliable. However, no responsibility is assumed by ICP DAS for it's use, nor for any infringements of patents or other rights of third parties resulting from it's use.

Copyright

Copyright 2012 by ICP DAS. All right are reserved

Trademark

The names used for identification only maybe registered trademarks of their respective companies.

PISO-PS300(U) 3 axis PCI bus stepping/servo motor control board

PISO-PS300(U) is a 3-axis, command-type, stepping/servo motor control board. The embedded CPU of PISO-PS300(U) performs the motion command transferred from host-PC via a 2K bytes FIFO. It also sends the positions and status back to host-PC via another 2K bytes FIFO. This buffer provides time buffer, so, it is very suitable for windows operating system. This board provides DOS, windows 95 and windows NT drivers.

Features

- 3-axis pulse output stepping/servo PCI control card.
- Universal PCI bus for PISO-PS300U (the PISO-PS300 only support 5V PCI bus)
- Maximum output pulse rate: 1MHz.
- Simulation mode / real mode.
- Encoder/pulse read back.
- Programmable output mode: CW/CCW, Pulse/Direction
- 3-axis linear interpolation, 2-axis circular interpolation.
- Programmable trapezoidal speed profile.
- Programmable DDA period.
- Programmable direction configuration.
- Programmable 2 speed home return, home preset, home direction.
- Home, forward, backward limit switches per axis.
- Hardware emergency stop, software emergency stop.
- Limit switch auto-protection.
- Programmable limit switch normal state: N.O. (normal open) or N.C. (normal close).
- 8 digital inputs, 7 digital outputs.
- 2500V optical isolation.
- Embedded CPU, totally 45 command set.
- DOS, windows 95/98, windows NT DLL driver.
- BCB, VB, Delphi driver.

Option

- DB-8R Daughter board.

PISO-PS300(U) Contents

1. Introduction	4-4
1.1 System Block Diagram	4-4
1.2 DDA technology	4-5
1.3 The operating mode	4-8
2. Hardware	4-10
2.1 Hardware address selection	4-10
2.2 Registers of PISO-PS300(U) Board	4-10
2.3 Hardware configuration	4-12
2.3.1 Limit switch configuration	4-12
2.3.2 Direction configuration	4-13
2.3.3 Turn Servo ON/OFF	4-13
2.4 Auto-protection	4-14
2.5 Connection	4-15
3. Software	4-22
3.1 The required software skeleton	4-22
3.2 Functions	4-25
3.2.1 Loading and unloading driver commands (only for windows)	4-26
3.2.2 Setting commands	4-26
3.2.3 Stop commands	4-29
3.2.4 Motion commands	4-31
3.2.5 Get information	4-40
3.2.6 Others	4-43
3.2.7 New interpolation command	4-45
4. Driver	4-50
DOS Driver(C, C++), Windows 95 Driver, Windows NT Driver	4-50
5. Example	4-51
5.1 DOS example	4-51
5.2 Windows example	4-52
6. Application notes	4-53
6.1 Functional testing	4-54
6.2 Hand wheel input	4-56
7. PISO-PS300U new function	4-62

1. Introduction

1.1 System Block Diagram

PISO-PS300(U) is a microprocessor based and 3- axis pulse type (max. pulse rate: 1MHz) stepping/servo motion control board. It contains a 2K bytes-FIFO to receive motion command from host PC, and it also sends the positions and status back to host-PC via the other 2K bytes FIFO. The motion profile is generated by microprocessor. This microprocessor also handles auto-protection function. Each digital I/O supports 2500Vrms optical isolation.

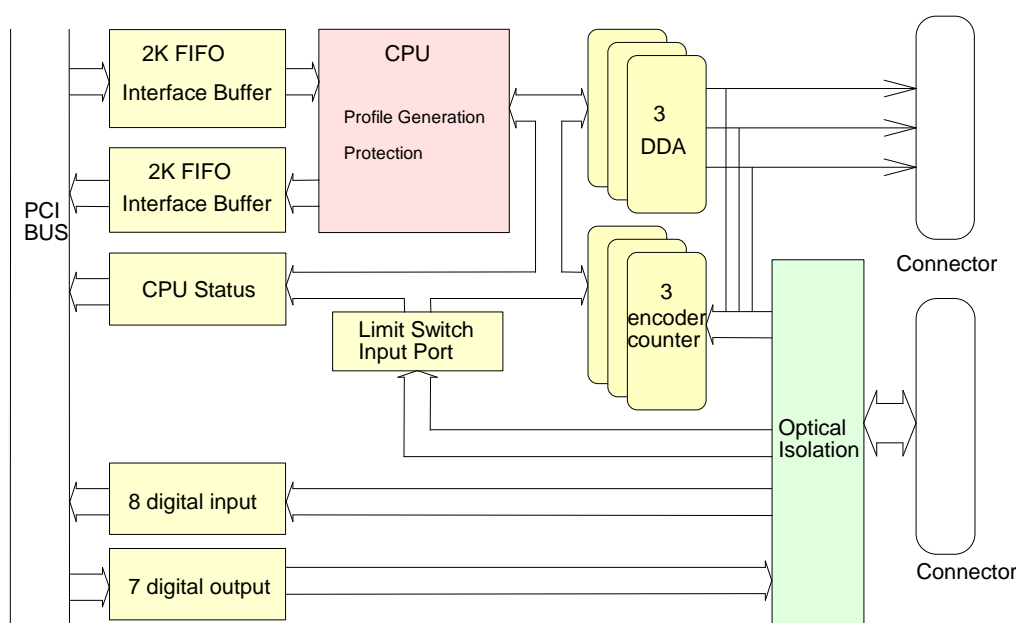

Figure(1) block diagram of PISO-PS300(U)

1.2 DDA Technology

The DDA chip is heart of PISO-PS300(U) card, it will generate equal-space pulse train corresponding to specific pulse number during a DDA period. This mechanism is very useful to execute pulse generation and interpolation function. The DDA period can be determined by DDA cycle. Table(1) shows the relation among DDA cycle, DDA period and output pulse rate. When DDA cycle set to 1, the DDA period is equal to $(1+1) \times 1.024\text{ms} = 2.048\text{ms}$. The output pulse number can be set to 0~2047, therefore the maximum output pulse rate will be 1Mpps. The minimum output pulse rate is 3.83pps when set DDA cycle=254 (DDA period = $(254+1) \times 1.024\text{ms} = 261.12\text{ms}$).

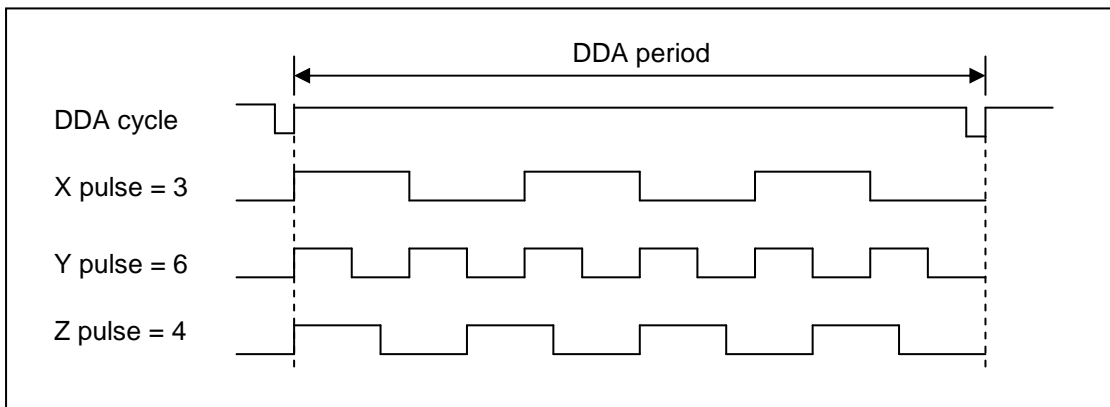

Figure(2) DDA mechanism

Table(1) The Relation among DDA cycle, DDA period and output pulse rate.

DDA cycle	DDA period	Max. pulse rate(n=2047)	Min. pulse rate (n=1)
1	2.048ms	999511pps	488pps
2	3.072ms	666341pps	325pps
3	4.096ms	.	.
.	.	.	.
N	$(N+1) \times 1.024\text{ms}$	$2047 / (\text{DDA period})$	$1 / (\text{DDA period})$
.	.	.	.
254	261.12ms	7839pps	3.83pps

The DDA cycle can be set by MSTEP3_SET_VAR() command which described in chapter 3. The selection criterion of DDA cycle was described as following.

(1) The required max. output pulse rate.

$$PR_{max} = \frac{V_{max} * N / 60}{2047}$$

$$PR_{max} = \frac{V_{max} * N}{(DDA_{cycle} + 1) * 1.024ms * 60}$$

PRmax : max. output pulse rate.

Vmax : max. speed (rpm).

N : the pulse number of stepping motor per revolution.
(pulse/rev).

2. The required speed resolution.

The maximum output pulse number is Np(0~2047), therefore the speed resolution is Vmax(max. speed)/Np. The DDA cycle can be obtained by following equation.

$$PR_{max} = \frac{Np}{(DDA_{cycle} + 1) * 1.024ms}$$

3. When choose large DDA cycle (DDA period), it will occur vibration between different pulse input which generally can be observed during acceleration or deceleration. So, the small DDA cycle, the smooth acceleration/deceleration curve as long as the speed resolution is acceptable.

Example: Stepping Motor

The specification of stepping motor is 500 pulse/rev, max. speed 500 rpm, speed resolution 2 rpm.

The required max. pulse rate

$$PR_{max} = 500 \text{ rpm} * 500 / 60 = 4166.67 \text{ pps}$$

The maximum output pulse

$$Np = 500 \text{ rpm} / 2 \text{ rpm} = 250 \text{ pulse number}$$

The DDA cycle can be calculated by follow equation

$$PR_{max} = \frac{Np}{(DDA_{cycle} + 1) * 1.024ms}$$

$$4166.67 = \frac{250}{(DDA_{cycle} + 1) * 1.024ms}$$

$$DDA \text{ cycle} = 58$$

$$\text{High Speed} = 247 \text{ pulse } (4166.67 * 58 * 0.001024)$$

The above results means that maximum speed is 500rpm when send command MSTEP3_SET_VAR(0, 58, 2, 2, 247, 50) to PISO-PS300(U) card.

Example: Pulse type input Servo Motor

The specification of servo motor is 8000 pulse/rev, max. speed 3000 rpm, speed resolution 2 rpm.

The required max. pulse rate

$$\text{PR}_{\text{max}} = 3000 \text{ rpm} * 8000 / 60 = 400,000 \text{ pps}$$

The maximum output pulse

$$N_p = 3000 \text{ rpm} / 2 \text{ rpm} = 1500 \text{ pulse number}$$

The DDA cycle can be calculated by follow equation

$$\text{PR}_{\text{max}} = \frac{N_p}{(DDA_{\text{cycle}} + 1) * 1.024 \text{ms}}$$

$$400,000 = \frac{1500}{(DDA_{\text{cycle}} + 1) * 1.024 \text{ms}}$$

$$\text{DDA cycle} = 3$$

$$\text{High Speed} = 1638 \text{ pulse } (400,000 * 4 * 0.001024)$$

The above results means that maximum speed is 3000rpm when send command MSTEP3_SET_VAR(0, 3, 2, 2, 1638, 100) to PISO-PS300(U) card.

1.3 The Operating Mode

For easily developing your system, PISO-PS300(U) board provides two operating mode: simulation mode / real mode. The following diagram shows the internal circuit of board

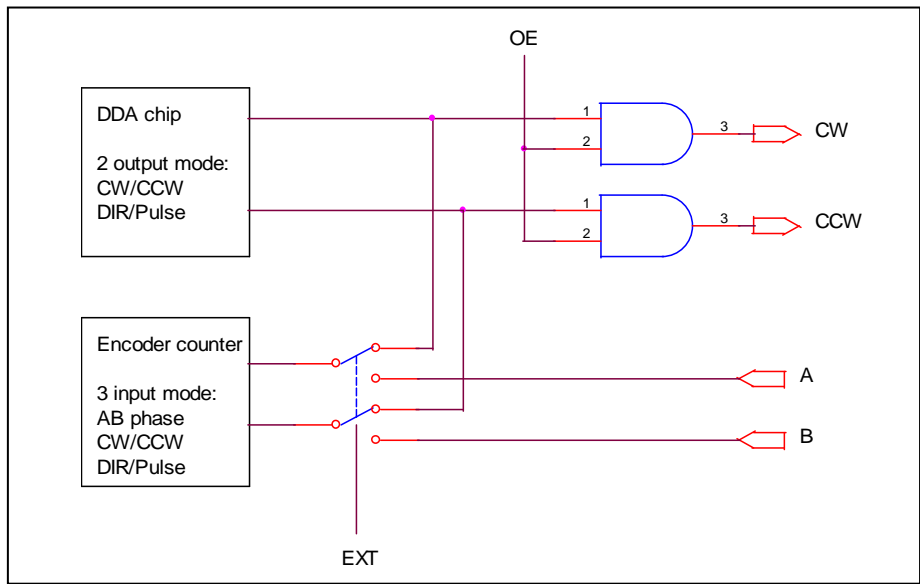

The output pins CW and CCW can be set as output enable or disable by OE signal. The encoder counter source signal can be connect to outside (A/B) or internal DDA chip by EXT signal.

Simulation mode

In simulation mode, the PISO-PS300(U) control board will simulate the motion profile according to the motion command that received from host PC, and then the PISO-PS300(U) will send the 3-axis positions back to host PC. The PISO-PS300(U) control board will not output pulse to motor driver by set OE=0. The encoder counter counts the internal DDA output pulse by set EXT=0. Therefore, the positions which read from the encoder counter is really output pulse number.

This mode is very useful and efficient in the design phase. The simulation mode can be operated off from machine. The user can debug and develop the software previously or at home. And if the user has the daughter board DB-8R, it can also simulate the digital input/output like as a machine.

The positions and status can be received from MSTEP3_GET_CARD (cardNo) command which must use a timer interrupt to receive, please

refer to chapter 3 software.

Real mode

In real mode, the output mode of DDA chip can be set as CW/CCW or DIR/PULSE mode according to user's motor driver, and set OE=1 for output enable. Setting EXT=1, the source signal of encoder counter come from external input. The input mode of encoder counter could be three kind mode: AB phase, CW/CCW and DIR/PULSE.

Software emergency stop

The servo command can be terminated from host-PC using software control. The user can use MSTEP3_STOP_ALL() or MSTEP3_EMG_STOP() command to terminate the servo commands which is executing in PISO-PS300(U) board. This command can clear all the commands pending in FIFO buffer.

2 Hardware

2.1 Hardware address selection

The hardware address can be set as 0~15 by A0~A3. There is a DIP switch on PISO-PS300(U) board for hardware address selection.

This hardware address can be selected using MSTEP3_REGISTRATION(cardNo, address) command. The MSTEP3_REGISTRATION() command has been described in chapter 3.

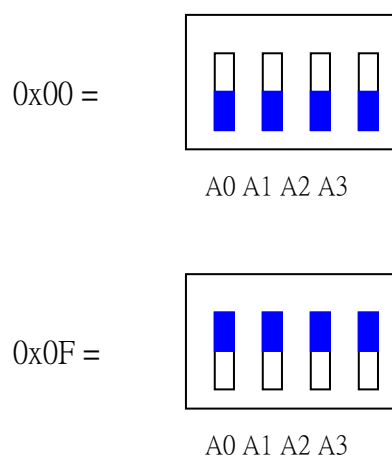

Figure(3) Hardware address selection

2.2 Registers of PISO-PS300(U) board

The PISO-PS300(U) has 6 registers including FIFO1 register, FIFO2 register, RSTFIFO1 register, DI register, DO register and MSC register.

(1) FIFO1 register (pcibase + 0xc0) (write only)

PISO-PS300(U) driver will send motion command via this register. Please do not use this register to write anything, otherwise the PISO-PS300(U) will not operate properly.

(2) RSTFIFO1 register (pcibase + 0xc4) (write only)

This register is used to reset FIFO1 for clear all of commands pending in the FIFO1 buffer.

(3) DO register (pcibase + 0xc8) (write only)

MSB 7	6	5	4	3	2	1	0 LSB
EMG	DO6	DO5	DO4	DO3	DO2	DO1	DO0

MSB7 bit is reserved for software emergency stop signal, please don't use it.

(4) FIFO2 register (pcibase + 0xc0) (read only)

This register is used to receive the message coming from PISO-PS300(U) board. This message includes PISO-PS300(U) status, command position, actual position. Please refer to chapter 3 for more information. Please don't read this register, otherwise the message might be lost.

(5) MSC register (pcibase + 0xc4) (read only)

MSB 7	6	5	4	3	2	1	0 LSB
/EMG	/Zstop	/Ystop	/Xstop	/F2HF	/F2EF	/F1FF	/F1EF

/EMG: emergency switch, low active.

/Xstop, /Ystop, /Zstop: indicate which axis is stop, low active

/F2HF: indicate receiving FIFO is half full.

/F2EF: indicate receiving FIFO is empty.

/F1FF: indicate transmissive FIFO is fully full.

/F1EF: indicate transmissive FIFO is empty.

(6) DI register (pcibase + 0xc8) (read only)

MSB 7	6	5	4	3	2	1	0 LSB
di7	di6	di5	Di4	Di3	di2	di1	di0

2.3 Hardware Configuration

2.3.1 Limit switch configuration

The profile generation and protection is executed by the CPU of PISO-PS300(U) board, The limit switches must be configured as the following figure, otherwise the motion command won't work properly,.

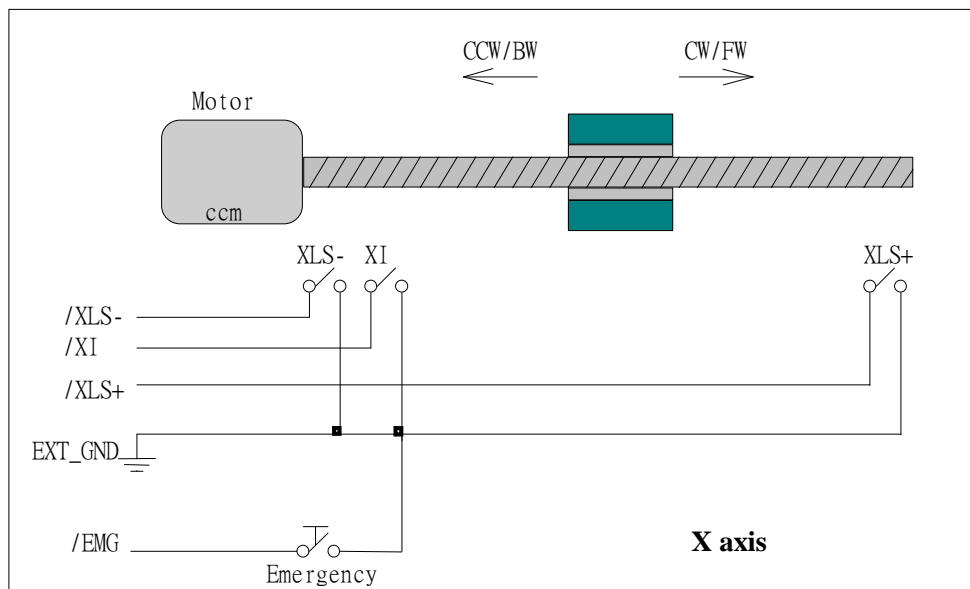

Figure(4) Limit switch configuration of X axis

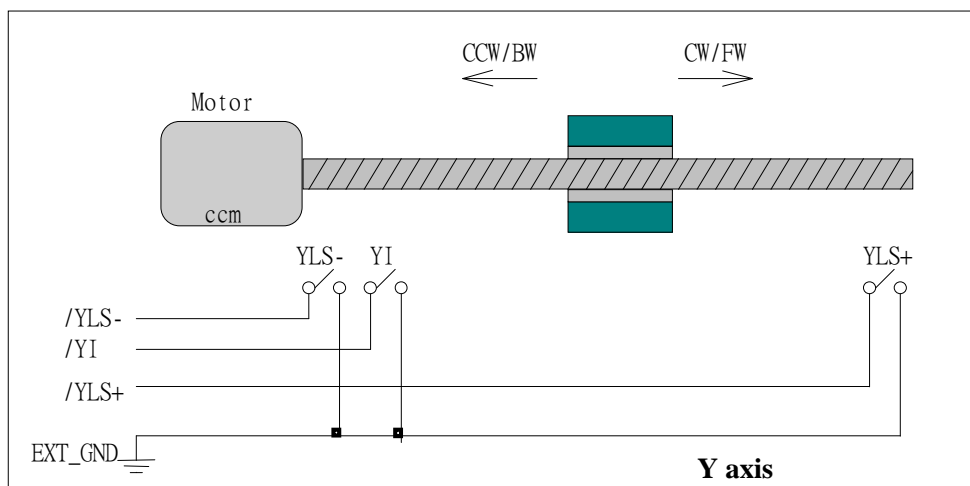

Figure(5) Limit switch configuration of Y axis

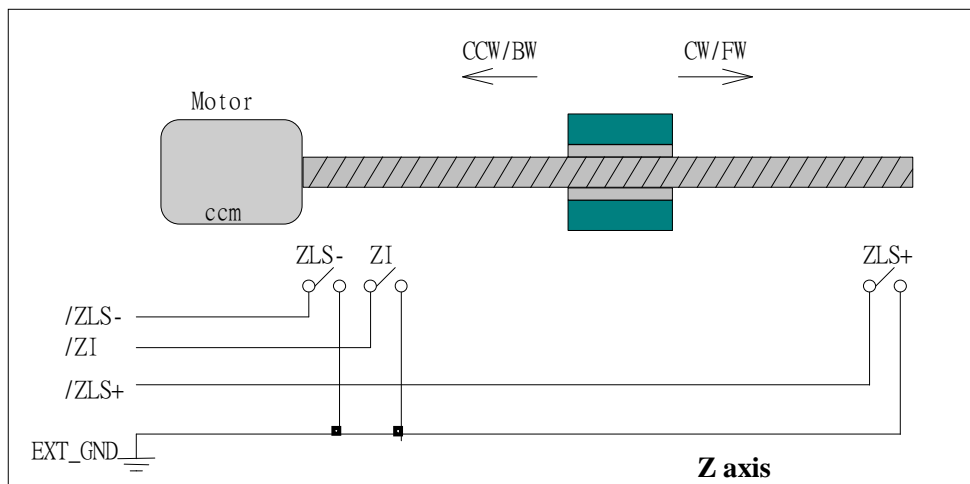

Figure(6) Limit switch configuration of Z axis

2.3.2 Direction configuration

Sometimes, the output direction of X-axis, Y-axis, Z-axis is not in the desired direction due to motor connection or gear train. It is recommended to unify the output direction as shown in Figure(4)(5)(6). The CW/FW direction is defined as toward outside from motor and the CCW/BW direction is defined as toward inside to motor. The `MSTEP3_SET_DEFDIR(cardNo, defdirX, defdirY, defdirZ)` command provides parameters `NORMAL_DIR` (0) and `REVERSE_DIR` (1) to define the rotating direction of motor.

2.3.3 Turn Servo ON/OFF (Hold ON/OFF)

The `MSTEP3_SET_SERVO_ON(cardNo, sonX, sonY, sonZ)` command provides parameters `ON` (1) and `OFF` (0) to turn Servo ON or OFF. The internal circuit of Servo-ON is sink-type connection as the following figure.

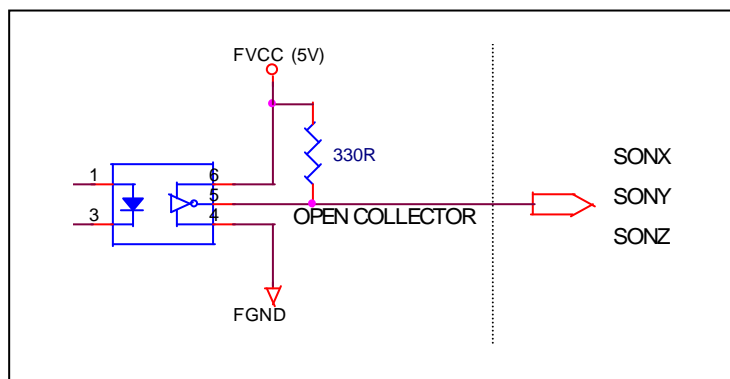

Figure(7) internal circuitry of Servo-ON signal

2.4 Auto-protection

PISO-PS300(U) board supports a automatic protection system.

- (a) When X(Y)(Z)-axis command is executed and the motor moves toward CW/FW direction, all axis will immediately stop when XLS+ (YLS+) (ZLS+) is touched. To release this protection, the X(Y)(Z)-axis must move toward CCW/BW direction.
- (b) When X(Y)(Z)-axis command is executed and the motor moves toward CCW/BW direction, all axis will immediately stop when XLS- (YLS-) (ZLS-) is touched. To release this protection, the X(Y)(Z)-axis must move toward CW/FW direction.
- (c) When any of the /EMG switches is touched, all motion command will be terminated and all motors will stop immediately. Meanwhile, the servo ON signal will be automatical turn off for rotating the shaft by manual. The servo ON signal will recover after released the /EMG switches.

2.5 Connection

(1) Pin assignment

Table(1) CN2 connector

pin name	pin number	description
CW_PULSEX	1	CW or PULSE output of X axis
CCW_DIRX	2	CCW or DIR ground of X axis
CW_PULSEY	3	CW or PULSE output of Y axis
CCW_DIRY	4	CCW or DIR ground of Y axis
FGND	5	Isolated ground
SONX	6	servo on signal of X axis
FVCC	7	Isolated 5V output, max. 25mA
SONY	8	servo on signal of Y axis
	9	No used

Table(2) CN3 connector

pin name	pin number	Description
CW_PULSEZ	1	CW or PULSE output of Z axis
CCW_DIRZ	2	CCW or DIR ground of Z axis
SONZ	3	servo on signal of Z axis
FVCC	4	Isolated 5V output, max. 25mA
FGND	5	Isolated ground
/ZI	6	home index switch of Z axis, active low for N.O.
/ZLS+	7	Positive limit switch of Z axis, active low for N.O.
/ZLS-	8	Negative limit switch of Z axis, active low for N.O.
VEXT	9	external power (apply 12~24V)

Table(3) CN4 connector

pin name	pin number	description
/XLS+	1	Positive switch of X axis, active low for N.O.
/XLS-	2	Negative limit switch of X axis, active low for N.O.
/YLS+	3	Positive limit switch of Y axis, active low for N.O.
/YLS-	4	Negative limit switch of Y axis, active low for N.O.
/XI	5	home index switch of X axis, active low for N.O.
/YI	6	home index switch of Y axis, active low for N.O.
/EMG	7	Emergency input, active low for N.O.
/IP1	8	digital input
/IP2	9	digital input
/IP3	10	digital input
/IP4	11	digital input
/IP5	12	digital input
/IP6	13	digital input
/IP7	14	digital input
/IP8	15	digital input
VEXT	16	external power (apply 12~24V)
/OP1	17	digital output
/OP2	18	digital output
/OP3	19	digital output
/OP4	20	digital output
/OP5	21	digital output
/OP6	22	digital output
/OP7	23	digital output
	24	No used
EXT_GND	25	external ground

Table(4) CN1 connector

pin name	pin number	description
1A+	1	A+ input of X axis encoder
1A-	2	A- input of X axis encoder
1B+	3	B+ input of X axis encoder
1B-	4	B- input of X axis encoder
5V	5	Isolated 5V supply, max. 50mA (sum of pin 5,9,17)
GND	6	encoder ground
1C+	7	C+ input of X axis encoder
1C-	8	C- input of X axis encoder
5V	9	Isolated 5V supply, max. 50mA (sum of pin 5,9,17)
3A+	10	A+ input of Z axis encoder
3B+	11	B+ input of Z axis encoder
3C+	12	C+ input of Z axis encoder
	13	no used
2C-	14	C- input of Y axis encoder
2C+	15	C+ input of Y axis encoder
GND	16	encoder ground
5V	17	Isolated 5V supply, max. 50mA (sum of pin 5,9,17)
2B-	18	B- input of Y axis encoder
2B+	19	B+ input of Y axis encoder
2A-	20	A- input of Y axis encoder
2A+	21	A+ input of Y axis encoder
GND	22	encoder ground
3A-	23	A- input of Z axis encoder
3B-	24	B- input of Z axis encoder
3C-	25	C- input of Z axis encoder

(2) The connection of pulse output

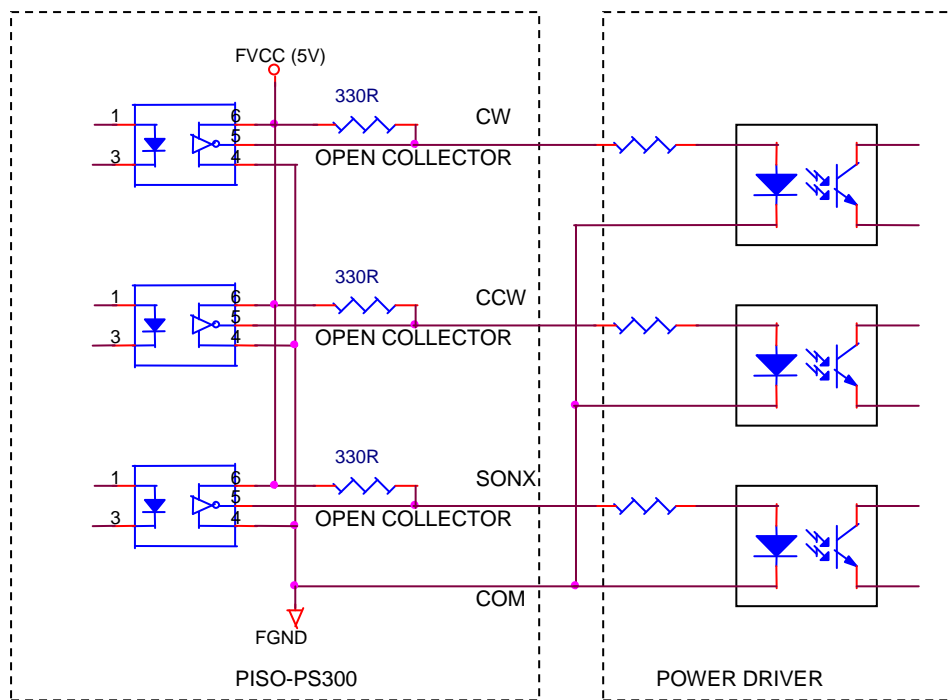

Source type connection

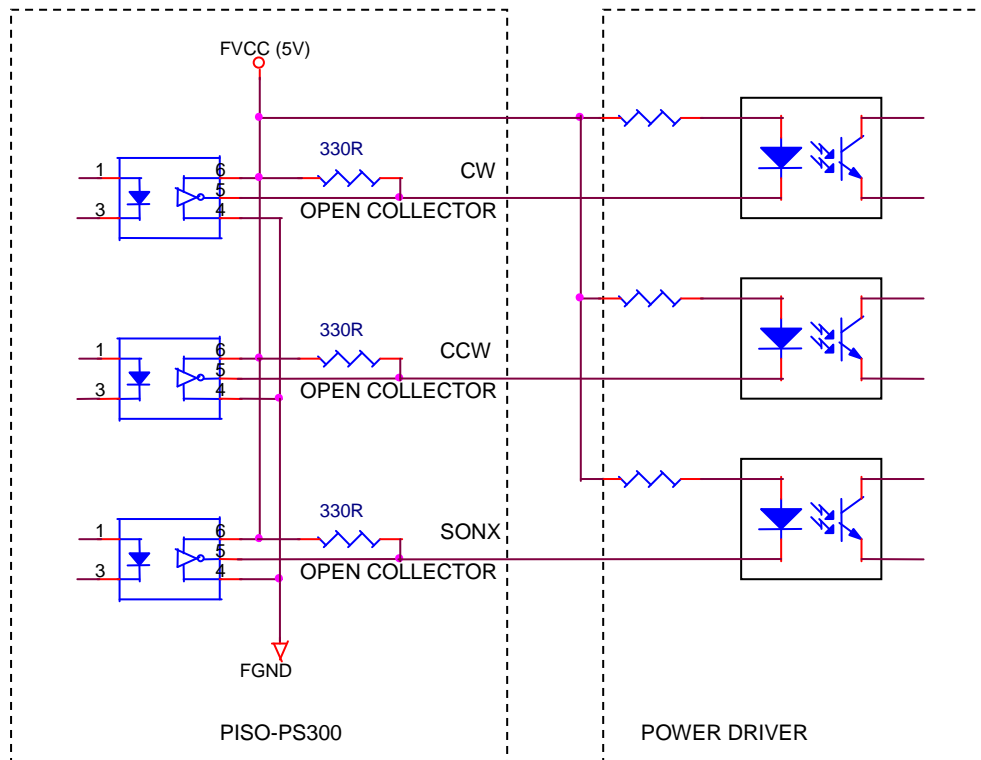

Sink type (open collector) connection

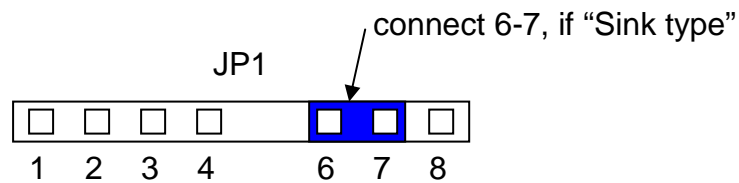

Sink type (open collector hardware setting)

(3) The connection of limit switches and digital inputs

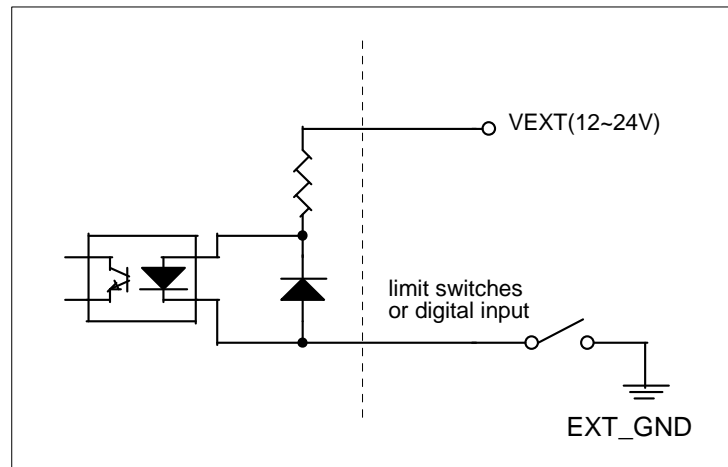

Figure(8)

(4) The connection of digital outputs

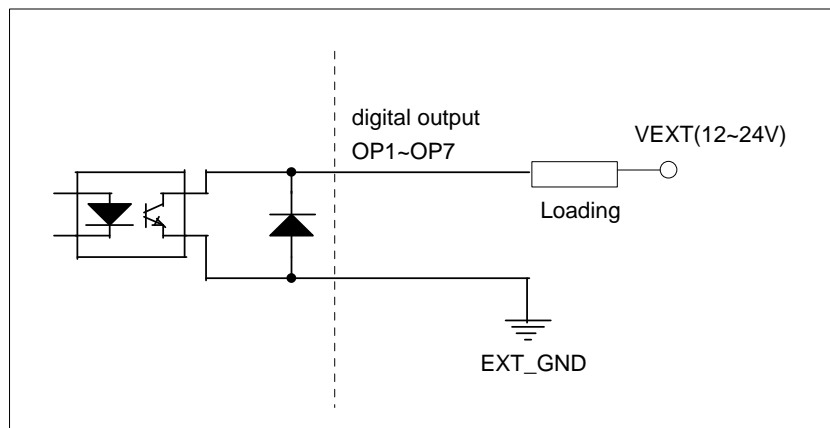

Figure(9)

(5) The connection of encoder

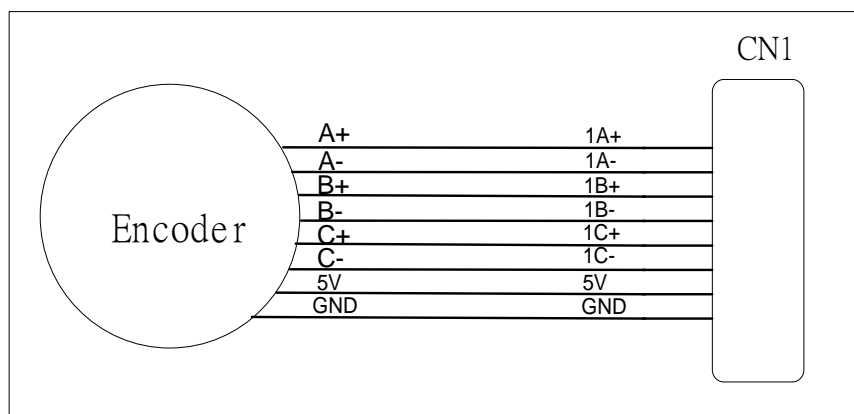

Figure (10) Connection between encoder and PISO-PS300(U) card

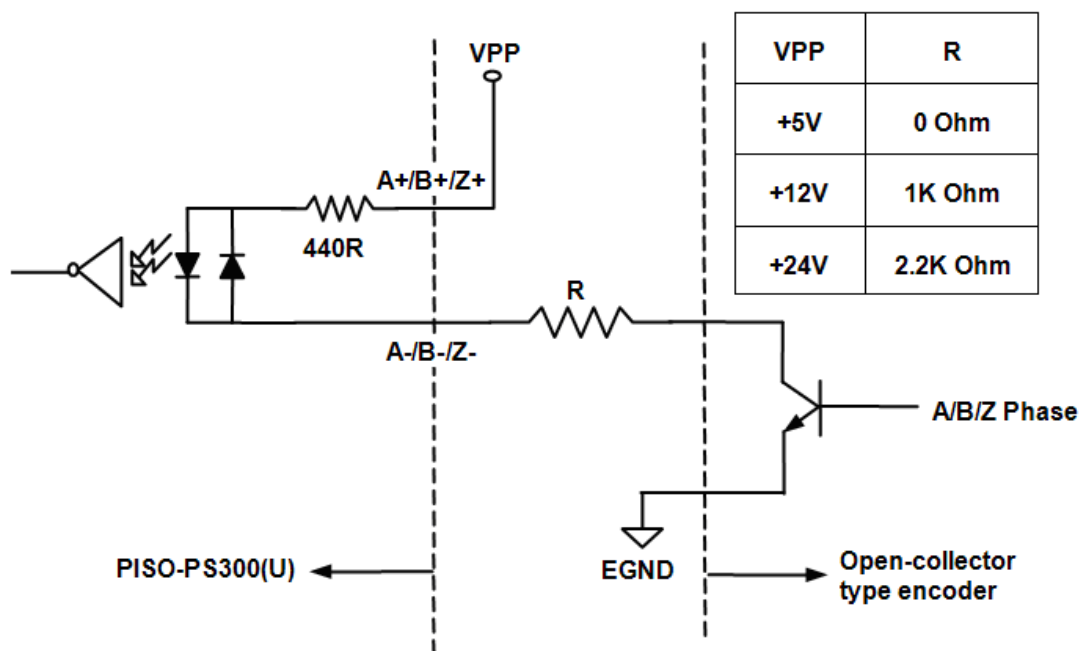
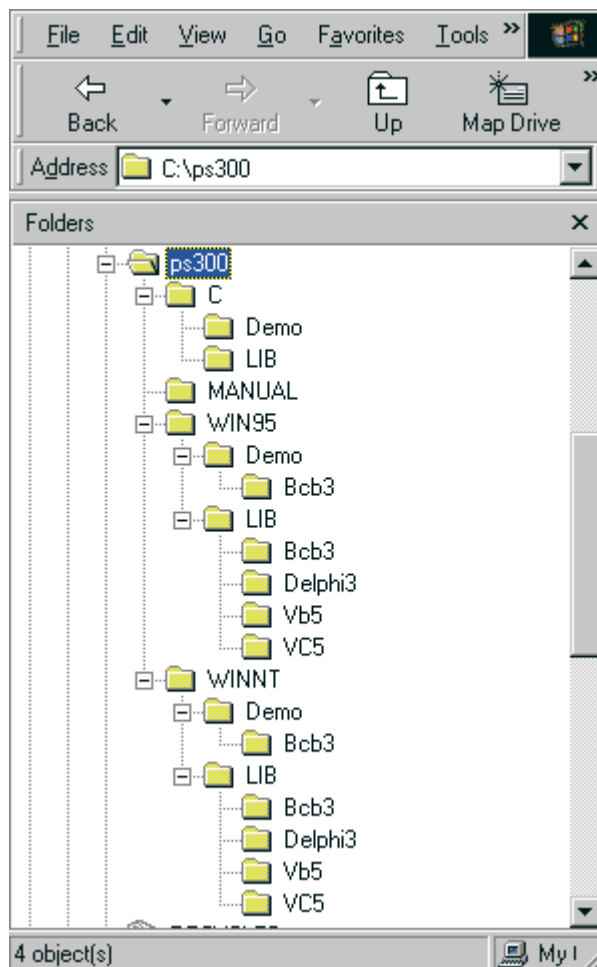

Figure (11) Connection of open-collector type encoder

3. Software

Directories



The software includes libraries and demonstrations of DOS(C++), windows 95 and windows NT.

3.1 The required software skeleton

To operate PISO-PS300(U) board properly, the software require some process and a timer interrupt (10ms) to get the information transferred from PISO-PS300(U) board.

The minimum software requirements:

- (1) load VXD file (if windows application)
- (2) PISO-PS300(U) registration
- (3) parameter setting

- (4) motion command
- (5) release VXD file (if windows application)
- (6) 10ms timer interrupt (mandatory)

MSTEP3_INITIAL();	(1). load VXD file
exist=MSTEP3_REGISTRATION(CARD1,address);	(2). registration Select address and check it is exist or not.
MSTEP3_RESET_SYSTEM(CARD1); MSTEP3_SET_NC(CARD1,NO); MSTEP3_SET_CONTROL_MODE(CARD1,x_mode, y_mode, z_mode); MSTEP3_SET_VAR(CARD1, DDA, AD, LSP, HSP, arc_speed); MSTEP3_SET_DEFDIR(CARD1, x_dir, y_dir, z_dir); MSTEP3_SET_SERVO_ON(CARD1, x_son, y_son, z_son);	(3) parameter setting reset PISO-PS300(U) board set normal close as NO set control mode set parameters of motion profile set direction set servo on
MSTEP3_BACK_HOME(CARD1, X_axis, home_speed, search_speed); MSTEP3_PULSE_MOVE(CARD1, X_axis, 50000, 1000); ...	(4) motion commands
MSTEP3_RESET_SYSTEM(CARD1); MSTEP3_END();	reset PISO-PS300(U) board (5) release VXD file

<pre> void __fastcall TMSTEP::Timer1Timer(TObject *Sender) { char str[20]; Timer1->Interval = 10; //10ms card1.ip = MSTEP3_DI(CARD1); card1.msc= MSTEP3_MSC(CARD1); if (card1.exist==YES) { MSTEP3_GET_CARD(CARD1); card1.ls =MSTEP3_GET_LIMIT(CARD1); card1.p1 =MSTEP3_GET_P1(CARD1); card1.XC =MSTEP3_GET_XC(CARD1); card1.XP =MSTEP3_GET_XP(CARD1); card1.YC =MSTEP3_GET_YC(CARD1); card1.YP =MSTEP3_GET_YP(CARD1); card1.ZC =MSTEP3_GET_ZC(CARD1); card1.ZP =MSTEP3_GET_ZP(CARD1); } } </pre>	<p>(6) 10ms timer interrupt (demonstration for BCB)</p> <p>get digital input get limit switches</p> <p>get information from PISO-PS300(U) board</p> <p>get X axis command get X axis position get Y axis command get Y axis position get Z axis command get Z axis position</p>
--	--

3.2 Functions

Constants

```
#define YES    1
#define NO     0
#define ON     1
#define OFF    0
#define CW_CCW 0
#define PULSE_DIR 1
#define NORMAL_DIR 0
#define REVERSE_DIR 1
#define FW     0
#define BW     1
#define CW     0
#define CCW    1

#define X_axis 1
#define Y_axis 2
#define Z_axis 3

#define XY_plane 1
#define XZ_plane 2
#define YZ_plane 3

#define READY 0
#define BUSY  1

#define DDA_CW_CCW 0x00
#define DDA_DIR_PULSE 0x01
#define SERVO_ON 0x02
#define DDA_EN 0x04
#define DDA_OE 0x08

#define ENC_MARK 0x30
#define ENC_AB_PHASE 0x00
#define ENC_CW_CCW 0x10
#define ENC_DIR_PULSE 0x20
#define ENC_EXTERNAL 0x40
#define ENC_INTERNAL 0x00
```

3.2.1 Loading and unloading driver commands (only for windows)

(1) MSTEP3_INITIAL()

To load VxD driver.

(2) MSTEP3_END()

To release VxD driver.

3.2.2 Setting commands

(3) unsigned char MSTEP3_REGISTRATION(unsigned char cardNo, unsigned int address);

To select the hardware address of board and check it is exist or not.

The cardNo can be assign as 0~15 for the given address.

cardNo : card number 0~15.

address : select the address as well as hardware address on the board.

return NO : PISO-PS300(U) is not exist

YES : PISO-PS300(U) is exist

(4) MSTEP3_RESET_SYSTEM(unsigned char cardNo);

To reset PISO-PS300(U) board.

cardNo : card number 0~15.

(5) MSTEP3_SET_CONTROL_MODE(unsigned char cardNo, unsigned char x_mode, unsigned char y_mode, unsigned char z_mode);

To configure the output mode of DDA chip and the input mode of encoder counter.

cardNo : card number 0~15.

x_mode : x axis control mode

y_mode : y axis control mode

z_mode : z axis control mode

control mode:

MSB 7	6	5	4	3	2	1	0 LSB
xx	EXT	ES1	ES0	OE	EN	xx	DDAM

DDAM: set the output mode of DDA chip.

- 0: CW/CCW mode
- 1: DIR/PULSE mode

EN: enable or disable DDA

- 0: disable
- 1: enable

OE: set DDA output enable

- 0: disable output, for simulation mode.
- 1: enable output, for real mode.

ES1, ES0: set the input mode of the encoder counter.

- 00: AB phase mode
- 01: CW/CCW mode
- 10: DIR/PULSE mode

EXT: set the encoder counter input signal comes from external or internal.

- 0: internal
- 1: external

If configure as internal mode, the output mode of DDA chip should be the same as input mode of encoder counter, or you will not count the pulse.

**(6) MSTEP3_SET_VAR(unsigned char cardNo,
 unsigned char set_DDA_cycle,
 unsigned char set_Acc_Dec,
 unsigned int set_Low_Speed,
 unsigned int set_High_Speed,
 unsigned int set_arc_speed);**

cardNo : card number 0~15.

set_DDA_cycle : software DDA cycle.

set_Acc_Dec : accelerating/decelerating speed.

set_Low_speed : set end speed.

set_High_speed : set maximum speed.

set_arc_speed : set curve speed.

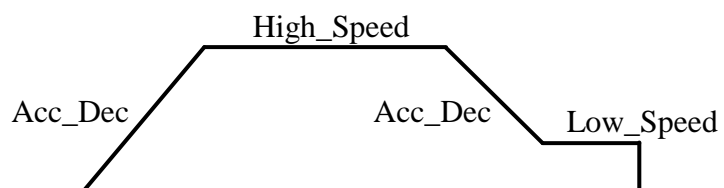

axis : X_axis, Y_axis or Z_axis.

(10) MSTEP3_PRESET_POSITION(unsigned char cardNo, unsigned char axis, long preset_position);

To pre-set the position in the PISO-PS300(U) card.

cardNo : card number 0~15.

axis : X_axis, Y_axis or Z_axis.

preset_position : the desired pre-set position.

(11) MSTEP3_SET_NC(unsigned char cardNo, unsigned char sw);

To set limit switch as N.C. (normal close) mode or not.

cardNo : card number 0~15.

sw byte:

MSB 7	6	5	4	3	2	1	0 LSB
0	0	0	EMGSW	ZSW	YSW	XSW	ALLSW

ALLSW: if ALLSW=1, all limit switches XLS+, XLS-, XI, YLS+, YLS-, YI, ZLS+, ZLS-, ZI, EMG are in N.C.(normal close) mode.

XSW: if XSW=1 and ALLSW=0, limit switches XLS+, XLS-, XI are in N.C. (normal close) mode.

YSW: if YSW=1 and ALLSW=0, limit switches YLS+, YLS-, YI are in N.C. (normal close) mode.

ZSW: if ZSW=1 and ALLSW=0, limit switches ZLS+, ZLS-, ZI are in N.C. (normal close) mode.

EMGSW: if EMGSW=1 and ALLSW=0, limit switch EMG is in N.C. (normal close) mode.

3.2.3 Stop Commands

(12) MSTEP3_STOP(unsigned char cardNo, unsigned char axis);

To stop the motion command of selected axis

cardNo : card number 0~15.

axis : selected axis

(13) MSTEP3_DEC_STOP(unsigned char cardNo, unsigned char axis);

Decelerating to stop the selected axis's motor.

cardNo : card number 0~15.

axis : selected axis

(14) MSTEP3_STOP_ALL(unsigned char cardNo);

To stop motion command immediately, this function is the same as emergency stop by hardware EMG switch.

cardNo : card number 0~15.

This command will clear all of pending commands in the buffer, and immediately terminate all commands which is executing in PISO-PS300(U) board.

(15) MSTEP3_EMG_STOP(unsigned char cardNo);

This function is the same as MSTEP3_STOP_ALL(), but MSTEP2_EMG_STOP() only can be used in timer interrupt routine.

cardNo : card number 0~15.

This command will clear all of pending commands in the buffer, and immediately terminate all commands which is executing in PISO-PS300(U) board.

Example:

```
void interrupt sampling_ISR(...) // 10ms sample once
{
  disable();
  .
  .
  .
  //----- check F7 -----
  if ((chkey=bioskey(1))!=0) //don't get key
    if (chkey==0x4100)
      {
        bioskey(0); //get key
        MSTEP3_EMG_STOP(CARD1);
      }
  .
  .
  .
  outportb(0x20,0x20);
  enable();
}
```

3.2.4 Motion commands

**(16) MSTEP3_BACK_HOME(unsigned char cardNo,
 unsigned char axis,
 unsigned char set_home_speed,
 unsigned char set_search_speed);**

This command is used to move the motor toward CCW/BW direction at home speed and then stop when home index switch /XI (/YI) (/ZI) is touched. And then the motor will move toward CW/FW direction at search speed to find absolute zero. When /XI=1 and C=0, the motor stop and set position to zero. In general, the search speed should be set to 2~5. If the search speed is too large, the absolute point might be lost. If search speed is set too small, it spends a lot of time.

cardNo : card number 0~15.

axis : selected axis.

0 < set_home_speed < 50

0 < set_search speed < 10

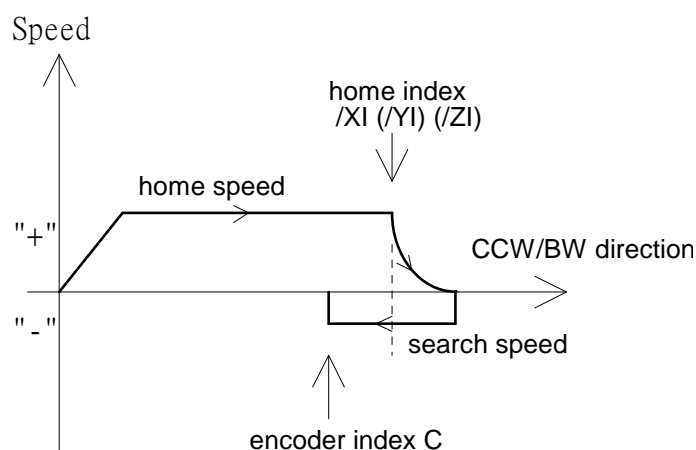

**(17) MSTEP3_BACK_HOME01(unsigned char cardNo,
 unsigned char axis,
 unsigned char set_home_speed);**

This command is used to move the motor toward CCW/BW direction at home speed and then stop when home index switch /XI (/YI) (/ZI) is touched, then set the position to zero.

This command is special for stepping motor without the encoder.

cardNo : card number 0~15.

axis : selected axis.

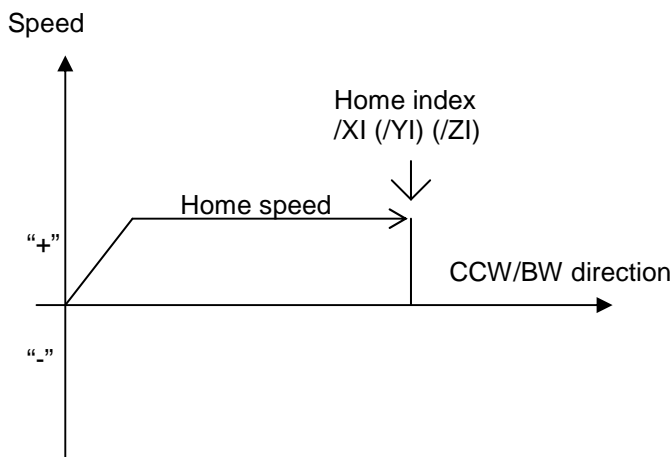

**(18) MSTEP3_PULSE_MOVE(unsigned char cardNo,
 unsigned char axis,
 long pulseN,
 unsigned int move_speed);**

cardNo : card number 0~15.

axis : selected axis.

pulseN : the distance to be moved.

when pulseN>0, move toward CW/FW direction

when pulseN<0, move toward CCW/BW direction

0 < move_speed <= 2040

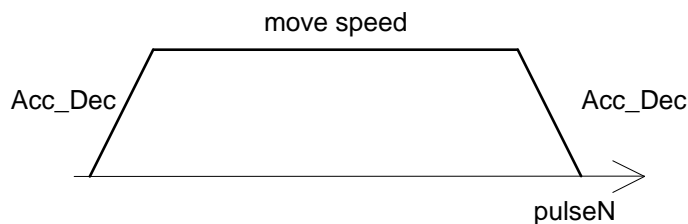

**(19) MSTEP3_INTP_PULSE(unsigned char cardNo,
int Xpulse,
int Ypulse,
int Zpulse);**

This command will move a short distance (interpolation short line) in X-Y-Z space. This command supports user to generate an arbitrary space curve in X-Y-Z space.

cardNo : card number 0~15.

-2040 <= Xpulse, Ypulse, Zpulse <= 2040

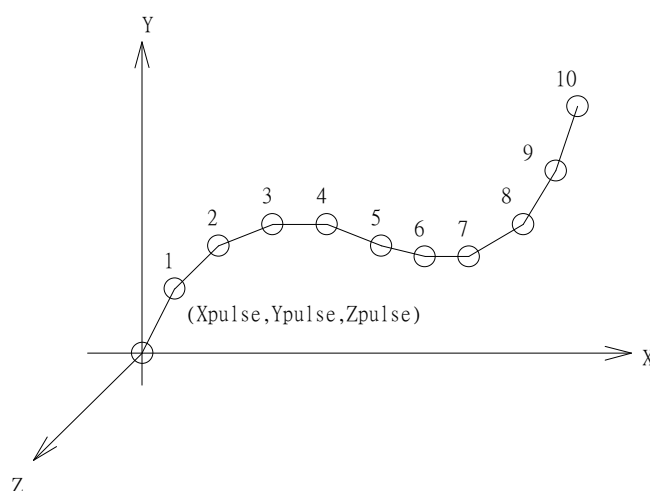

Example:

```
#define CARD1 1
MSTEP3_INTP_PULSE(CARD1,20,20,2);
MSTEP3_INTP_PULSE(CARD1,20,13,10);
MSTEP3_INTP_PULSE(CARD1,20,7,10);
MSTEP3_INTP_PULSE(CARD1,20,0,5);
MSTEP3_INTP_PULSE(CARD1,15,-5,5);
```

**(20) MSTEP3_CONSTANT_SPEED(unsigned char cardNo,
unsigned char axis,
unsigned char dir,
unsigned int move_speed);**

This command will accelerate or decelerate the selected axis's motor to the "move_speed". The rotating motor can be stop by the command MSTEP3_STOP() or MSTEP3_DEC_STOP(). **This command can be continuously input to SERVO300 card to change speed.**

cardNo : card number 0~15.

axis : selected axis.

1 : X axis

2 : Y axis

3 : Z axis

dir : moving direction.

0 : CW

1 : CCW

$0 < \text{move_speed} \leq 2040$

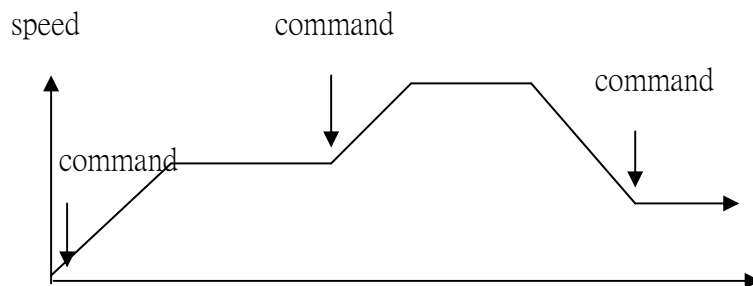

**(21) MSTEP3_INTP_XYZ(unsigned char cardNo,
long x, long y, long z,
unsigned int speed);**

This command will move a long distance interpolation line in X-Y-Z plane.

cardNo : card number 0~15.

$$-2^{31} + 1 \leq x \leq 2^{31} - 1$$

$$-2^{31} + 1 \leq y \leq 2^{31} - 1$$

$$-2^{31} + 1 \leq z \leq 2^{31} - 1$$

$$0 < \text{speed} \leq 2040$$

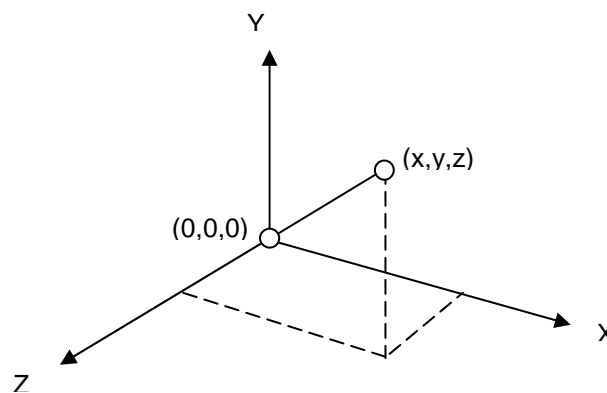

Example:

```
MSTEP3_INTP_XYZ(CARD1,2000,-3000,3333,1000);
```

```
MSTEP3_INTP_XYZ(CARD1,-500,200,200,500);
```

**(22) MSTEP3_INTP_LINE(unsigned char cardNo,
long x,
long y,
unsigned int speed);**

This command will move a long distance interpolation line in X-Y plane.

cardNo : card number 0~15.

$$-2^{31} + 1 \leq x \leq 2^{31} - 1$$

$$-2^{31} + 1 \leq y \leq 2^{31} - 1$$

$$0 < \text{speed} \leq 2040$$

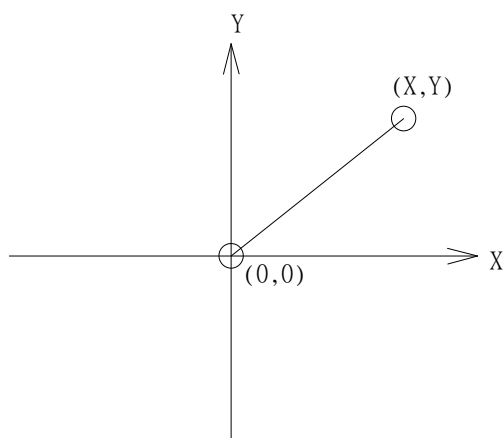

Example:

```
MSTEP3_INTP_LINE(CARD1,2000,-3000,1000);
```

```
MSTEP3_INTP_LINE(CARD1,-500,200,1000);
```

**(23) MSTEP3_INTP_LINE01(unsigned char cardNo,
unsigned char plane,
long x,
long y,
unsigned int speed);**

This command will move a long distance interpolation line in X-Y or X-Z or Y-Z plane.

plane :

1 : X-Y plane

2 : X-Z plane

3 : Y-Z plane

**(24) MSTEP3_INTP_CIRCLE(unsigned char cardNo,
long x, long y,
unsigned char dir, unsigned int speed);**

This command will generate an interpolation circle in X-Y plane. PC will automatically generate a trapezoidal speed profile of X-axis and Y-axis, and send these profile by way of MSTEP3_INTP_PULSE() command.

cardNo : card number 0~15.

x, y : center point of circle related to present position.

dir : moving direction.

0 : CW

1 : CCW

$-2^{31} + 1 \leq x \leq 2^{31} - 1$

$-2^{31} + 1 \leq y \leq 2^{31} - 1$

$0 < \text{speed} \leq 2040$

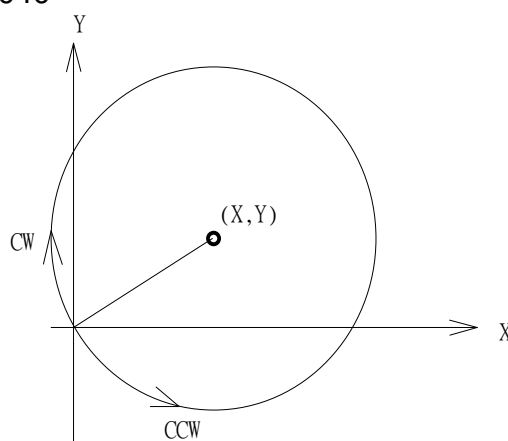

where radius = $\sqrt{X^2 + Y^2}$

Example:

`MSTEP3_INTP_CIRCLE(CARD1, 2000,-2000,CW,500);`

**(25) MSTEP3_INTP_CIRCLE01(unsigned char cardNo,
unsigned char plane, long x, long y,
unsigned char dir,
unsigned int speed);**

This command will generate an interpolation circle in X-Y or X-Z or Y-Z plane.

plane :

1 : X-Y plane

2 : X-Z plane

3 : Y-Z plane

**(26) MSTEP3_INTP_ARC(unsigned char cardNo,
 long x, long y, long R,
 unsigned char dir, unsigned int speed);**

This command will generate an interpolation arc in X-Y plane. PC will automatically generate a trapezoidal speed profile of X-axis and Y-axis, and send these profile by way of MSTEP3_INTP_PULSE() command.
 cardNo : card number 0~15.

x, y : end point of arc related to present position.

R : radius of arc.

if $R > 0$, the arc < 180 degree

if $R < 0$, the arc > 180 degree

dir : moving direction.

0 : CW

1 : CCW

R	dir	path of curve
$R > 0$	CW	'B'
$R > 0$	CCW	'C'
$R < 0$	CW	'A'
$R < 0$	CCW	'D'

$0 < \text{speed} \leq 2040$

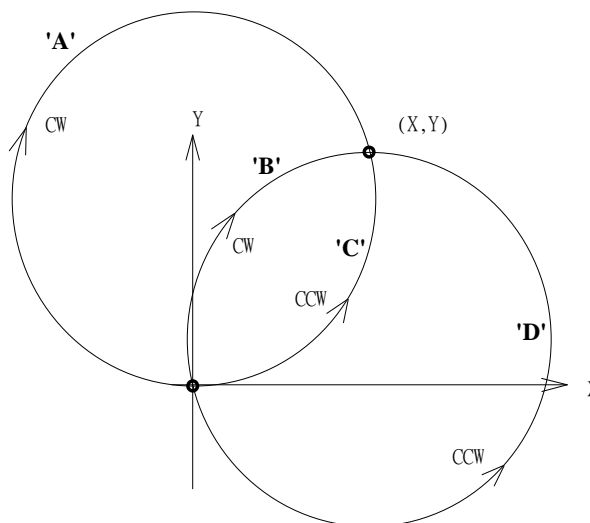

Restriction:

$$-2^{31} + 1 \leq x \leq 2^{31} - 1$$

$$-2^{31} + 1 \leq y \leq 2^{31} - 1$$

$$-2^{31} + 1 \leq R \leq 2^{31} - 1$$

$$R \geq \frac{\sqrt{x^2 + y^2}}{2}$$

Example:

```
MSTEP3_INTP_ARC(CARD1,2000,-2000,2000,CW,500);
```

**(27) MSTEP3_INTP_ARC01(unsigned char cardNo,
unsigned char plane, long x, long y,
long R, unsigned char dir,
unsigned int speed);**

This command will generate an interpolation arc in X-Y or X-Z or Y-Z plane.

plane :

1 : X-Y plane

2 : X-Z plane

3 : Y-Z plane

3.2.5 Get information

To get the information transferred from PISO-PS300(U) board, the user should construct a timer interrupt to poll information. The software skeleton has been described in chapter 3.1.

The MSTEP3_GET_CARD() command should be executed at the beginning and then to get information you need.

example:

```
void __fastcall TMSTEP::Timer1Timer(TObject *Sender)
{
char str[20];
Timer1->Interval = 10; //10ms
if (card1.exist==YES)
{
card1.ip = MSTEP3_DI(CARD1);
card1.msc= MSTEP3_MSC(CARD1);

MSTEP3_GET_CARD(CARD1);

card1.ls =MSTEP3_GET_LIMIT(CARD1);
card1.p1 =MSTEP3_GET_P1(CARD1);
card1.XC =MSTEP3_GET_XC(CARD1);
card1.XP =MSTEP3_GET_XP(CARD1);
card1.YC =MSTEP3_GET_YC(CARD1);
card1.YP =MSTEP3_GET_YP(CARD1);
card1.ZC =MSTEP3_GET_ZC(CARD1);
card1.ZP =MSTEP3_GET_ZP(CARD1);
}
}
```

(28) MSTEP3_GET_CARD(unsigned char cardNo)

This command uses timer interrupt to poll the information transferred from PISO-PS300(U) board.

CardNo : card number 0~15.

(29) unsigned char MSTEP3_GET_LIMIT(unsigned char cardNo)

The limit register contains

MSB 7	6	5	4	3	2	1	0 LSB
xx	/EMG	/ZLS-	/ZLS+	/YLS-	/YLS+	/XLS-	/XLS+

/EMG: emergency input, low active.

/XLS+: positive limit switch of X axis, active low.

/XLS-: negative limit switch of X axis, active low.

/YLS+: positive limit switch of Y axis, active low.

/YLS-: negative limit switch of Y axis, active low.

/ZLS+: positive limit switch of Z axis, active low.

/ZLS-: negative limit switch of Z axis, active low.

(30) unsigned char MSTEP3_GET_P1(unsigned char cardNo)

The P1 register contains

MSB 7	6	5	4	3	2	1	0 LSB
xx	C3	C2	C1	/ZI	/YI	/XI	xx

/XI, /YI, /ZI : indicate home index switch, active low.

C1, C2, C3 indicate the encoder index of X, Y, Z axis, respectively.

high active

(31) long MSTEP3_GET_XC(unsigned char cardNo)

Get the command position of X axis.

CardNo : card number 0~15.

(32) long MSTEP3_GET_XP(unsigned char cardNo)

Get the actual position of X axis.

CardNo : card number 0~15.

(33) long MSTEP3_GET_YC(unsigned char cardNo)

Get the command position of Y axis .

CardNo : card number 0~15.

(34) long MSTEP3_GET_YP(unsigned char cardNo)

Get the actual position of Y axis .

CardNo : card number 0~15.

(35) long MSTEP3_GET_ZC(unsigned char cardNo)

Get the command position of Z axis.

CardNo : card number 0~15.

(36) long MSTEP3_GET_ZP(unsigned char cardNo)

Get the actual position of Z axis

CardNo : card number 0~15.

3.2.6 Others

(37) unsigned char MSTEP3_DI(unsigned char cardNo)

To get the DI register

MSB 7	6	5	4	3	2	1	0 LSB
di7	di6	di5	di4	di3	di2	di1	di0

(38) MSTEP3_DO(unsigned char cardNo, unsigned char value)

To output DO port

MSB 7	6	5	4	3	2	1	0 LSB
don't use	DO6	DO5	DO4	DO3	DO2	DO1	DO0

(39) unsigned char MSTEP3_MSC(unsigned char cardNo)

To get the status of limit switch

MSB 7	6	5	4	3	2	1	0 LSB
/EMG	/Zstop	/Ystop	/Xstop	xx	xx	xx	xx

/Xstop, /Ystop, /Zstop : indicates which axis is stop, low active

/EMG : emergency switch, low active.

(40) MSTEP3_WAIT_X(unsigned char cardNo)

To wait X-axis goes to the STOP state.

(41) MSTEP3_WAIT_Y(unsigned char cardNo)

To wait Y-axis goes to the STOP state.

(42) MSTEP3_WAIT_Z(unsigned char cardNo)

To wait Z-axis goes to the STOP state.

(43) unsigned char MSTEP3_IS_X_STOP(unsigned char cardNo)

To check whether X axis is STOP or not.

Return value 0 (NO) : not yet stop

1 (YES) : stop

(44) unsigned char MSTEP3_IS_Y_STOP(unsigned char cardNo)

To check whether Y axis is STOP or not.

Return value 0 (NO) : not yet stop
 1 (YES) : stop

(45) unsigned char MSTEP3_IS_Z_STOP(unsigned char cardNo)

To check whether Z axis is STOP or not.

Return value 0 (NO) : not yet stop
 1 (YES) : stop

3.2.7 New Interpolation command

The new driver provide a set of state-machine-type interpolation command including:

- (46) MSTEP3_INTP_XYZ02(unsigned char cardNo,
long x, long y, long z,
unsigned int speed,
unsigned char acc_mode);**
- (47) MSTEP3_INTP_LINE02(unsigned char cardNo,
unsigned char plane,
long x,
long y,
unsigned int speed,
unsigned char acc_mode);**
- (48) MSTEP3_INTP_CIRCLE02(unsigned char cardNo,
unsigned char plane,
long x, long y,
unsigned char dir,
unsigned int speed,
unsigned char acc_mode);**
- (49) MSTEP3_INTP_ARC02(unsigned char cardNo,
unsigned char plane,
long x, long y, long R,
unsigned char dir,
unsigned int speed,
unsigned char acc_mode);**

acc_mode: 0: enable acceleration and deceleration profile
1: disable acceleration and deceleration profile

These command can be set acc_mode=1 to disable the acceleration and deceleration profile.

(50) unsigned char MSTEP3_INTP_STOP()

These command is to compute the interpolation service. It will return **READY(0)** for interpolation command completed. And retrun **BUSY(1)** for not yet complete.

(51) void MSTEP3_INTP_ONLINE_SETSPEED(unsigned int speed)

User can use this command to dynamicly set the interpolation moving speed when interpolation command(XYZ02, LINE02, CIRCLE02, ARC02) is running.

where, $0 < \text{speed} < 2040$

These 4 commands are state machine type command, they are only set parameters into the driver. The computing entity is in **MSTEP3_GET_CARD()** (only for windows) and **MSTEP3_INTP_STOP()**.

In windows application, when The MSTEP3_GET_CARD() command is running in the timer interrupt routine by 10ms, it will help to calculate the interpolation service.

Both of DOS and windows application, User can directly call the **do { } while (MSTEP3_INTP_STOP()!=READY)** to execute the computing entity. The user can monitor something or waiting for keyboard input in the do loop. Therefore, The user has chance to do the software stop or monitor something.

DOS application example1

```
MSTEP3_INTP_XYZ02(CARD1,1000,1000,0,20,1);
do
{
    show_panel();
    if (kbhit()) chkey=bioskey(0); //F7=0x4100
} while ( (chkey!= 0x4100) && (MSTEP3_INTP_STOP()!=READY) );
if (chkey==0x4100) MSTEP3_STOP_ALL(CARD1);
```

DOS application example2

```
void TimerInterrupt(void)
{
    MSTEP3_GET_CARD(CARD1);
    show_panel();
    if (kbhit())    chkey=bioskey(0); //F7=0x4100
}
void test_intp(void)
{
    MSTEP3_INTP_XYZ02(CARD1,1000,1000,0,20,1);
    do
    { } while ( (chkey!= 0x4100) && (MSTEP3_INTP_STOP()!=READY) );
    if (chkey==0x4100) MSTEP3_STOP_ALL(CARD1);
}
```

Windows application example1

```
void __fastcall TMSTEP::Timer1Timer(TObject *Sender)
```

```

{
    Timer1->Interval = 10; //10ms
    MSTEP3_GET_CARD(CARD1);
    show_panel();
}
void __fastcall TMSTEP::IntpLineClick(TObject *Sender)
{
char str[20];

if ( (MSTEP3_IS_X_STOP(CARD1)==NO)
    || (MSTEP3_IS_Y_STOP(CARD1)==NO)
    || (MSTEP3_IS_Z_STOP(CARD1)==NO))
{
    Application->MessageBox(
        "Motor's rotating, can't execute this command",
        "Message Box",
        MB_DEFBUTTON1);
    return;
};

ltoa(x, str, 10);
IntpLineDialog->Xpulse->Text = AnsiString(str);
ltoa(y, str, 10);
IntpLineDialog->Ypulse->Text = AnsiString(str);
ltoa(speed, str, 10);
IntpLineDialog->speed->Text = AnsiString(str);
IntpLineDialog->SelectPlane->ItemIndex = plane-1;

if (IntpLineDialog->ShowModal()==mrOk)
{
    x= (long)IntpLineDialog->Xpulse->Text.ToInt();
    y= (long)IntpLineDialog->Ypulse->Text.ToInt();
    speed= (unsigned int)IntpLineDialog->speed->Text.ToInt();
    plane= (unsigned char)(IntpLineDialog->SelectPlane->ItemIndex + 1);
    //MSTEP3_INTP_LINE01(CARD1,plane,x,y,speed);
    MSTEP3_INTP_LINE02(CARD1,plane,x,y,speed,0);
    do {Application->ProcessMessages();}
    while (MSTEP3_INTP_STOP()!=READY);
}
}

```

}
}

The example for wait stop command (DOS):

```

//test XYZ01, no acceleration
MSTEP3_INTP_XYZ02(CARD1,1000,1000,0,20,1);
do {} while (MSTEP3_INTP_STOP()!=READY);
MSTEP3_INTP_XYZ02(CARD1,2000,1000,0,22,1);
do {} while (MSTEP3_INTP_STOP()!=READY);
MSTEP3_INTP_XYZ02(CARD1,2000,2000,0,24,1);
do {} while (MSTEP3_INTP_STOP()!=READY);
MSTEP3_INTP_XYZ02(CARD1,1000,2000,0,26,1);
do {} while (MSTEP3_INTP_STOP()!=READY);

do {} while (MSTEP3_IS_X_STOP(CARD1)==NO);
delay(10000);

//test WAIT_X, WAIT_Y, WAIT_Z
MSTEP3_INTP_LINE02(CARD1, XY_plane, 10000,-10000,200,0);
do {} while (MSTEP3_INTP_STOP()!=READY);
MSTEP3_INTP_LINE02(CARD1, XY_plane, -10000, 10000,200,0);
do {} while (MSTEP3_INTP_STOP()!=READY);
MSTEP3_INTP_XYZ02(CARD1, 5000, -10000, -40000, 200, 0);
do {} while (MSTEP3_INTP_STOP()!=READY);

do {} while (MSTEP3_IS_X_STOP(CARD1)==NO);
do {} while (MSTEP3_IS_Y_STOP(CARD1)==NO);
do {} while (MSTEP3_IS_Z_STOP(CARD1)==NO);
MSTEP3_STOP_ALL(CARD1);
delay(10000);

MSTEP3_INTP_CIRCLE02(CARD1, XY_plane, 5000,-5000, CW, 200, 0);
do {} while (MSTEP3_INTP_STOP()!=READY);

do {} while (MSTEP3_IS_X_STOP(CARD1)==NO);
do {} while (MSTEP3_IS_Y_STOP(CARD1)==NO);
MSTEP3_STOP_ALL(CARD1);

```

4. Driver

DOS Driver (C, C++)

Item	File
Header file	MSTEP3.h
Library file	MSTEP3.lib
Example file	Sp3tcc.prj (turbo C++) Sp3bcc.ide (borland C++)

Windows 95 Driver

Item	File
Header file	Mstep32.h
ImportLibrary file	Mstep32.lib Bcstep32.lib (only for Borland C++)
Dynamic Link Library	Mstep32.dll(copy to c:\windows)
VxD file	Napdio.vxd(copy to c:\windows)
Example file	Bcmstep3.bpr(Borland C++ Builder) Bcmstep3.cpp main.cpp

Windows NT Driver

Item	File
Header file	Mstep32.h
ImportLibrary file	Mstep32.lib Bcstep32.lib (only for Borland C++)
Dynamic Link Library	Mstep32.dll(copy to c:\windows)
Driver	regdrv.bat napwnt.ini napwnt.sys regini.exe
Example file	Bcmstep3.bpr(Borland C++ Builder) Bcmstep3.cpp main.cpp

5. Example

5.1 DOS example

The execution file, SP3TCC.EXE/SP3BCC.EXE, is a testing program. It can let you fully understand the action of every command. The source files include SP3TCC.PRJ(SP3BCC.IDE), MAIN.CPP, MSTEP3.H and MSTEP3.LIB. The MAIN.CPP file provides several examples of MSTEP3 command set. If you have any questions about the command set, you can trace the MAIN.CPP source file.

The panel of SP3TCC.EXE has three areas :

(1) I/O information area

It indicates the status of limit switch, digital input/output and PISO-PS300(U) board.

(2) motion parameter area

It shows the variables of motion parameter. It also shows the command position and actual position of each axis.

(3) Command area

You can select any command and execute it.

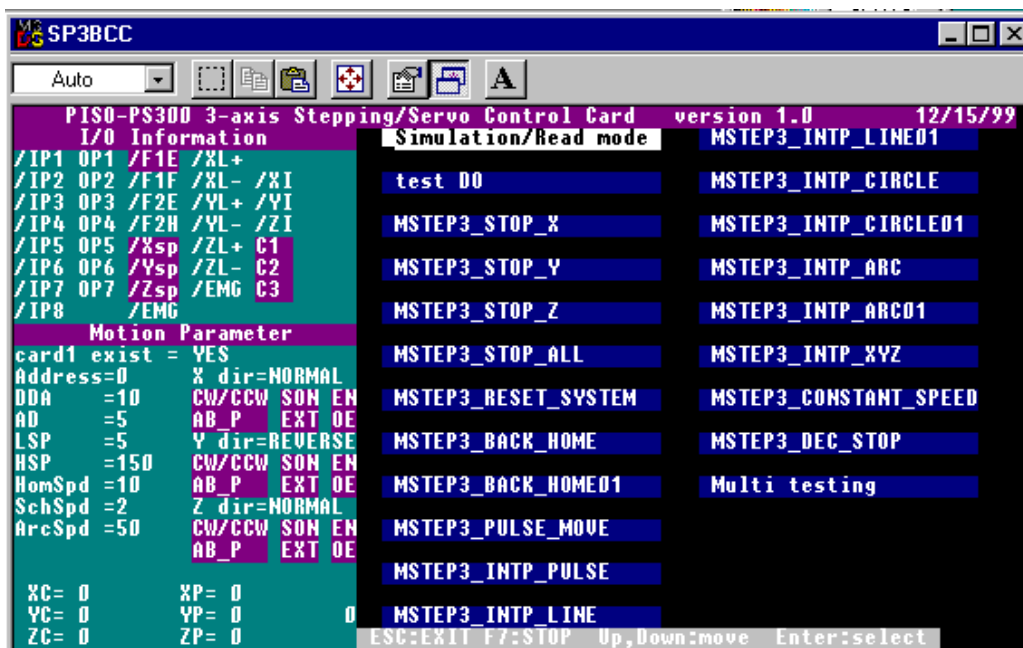

The panel of DOS example

5.2 Windows example

The bcmstep3.exe (source file included) is an example of PISO-PS300(U) board. It has windows95 and NT edition. If you have any question about PISO-PS300(U) command set, you can trace the source file.

The panel of bcmstep3.exe has three areas :

(1) I/O information area

It indicates the status of limit switches, digital inputs/outputs and PISO-PS300(U) board.

(2) Motion parameter area

It shows the variables of motion parameter. It also shows the command position and actual position of each axis. All parameters can be modified and updated by pressing the “Update Servo Parameters” menu bar.

(3) Command area

You can select any command and execute it.

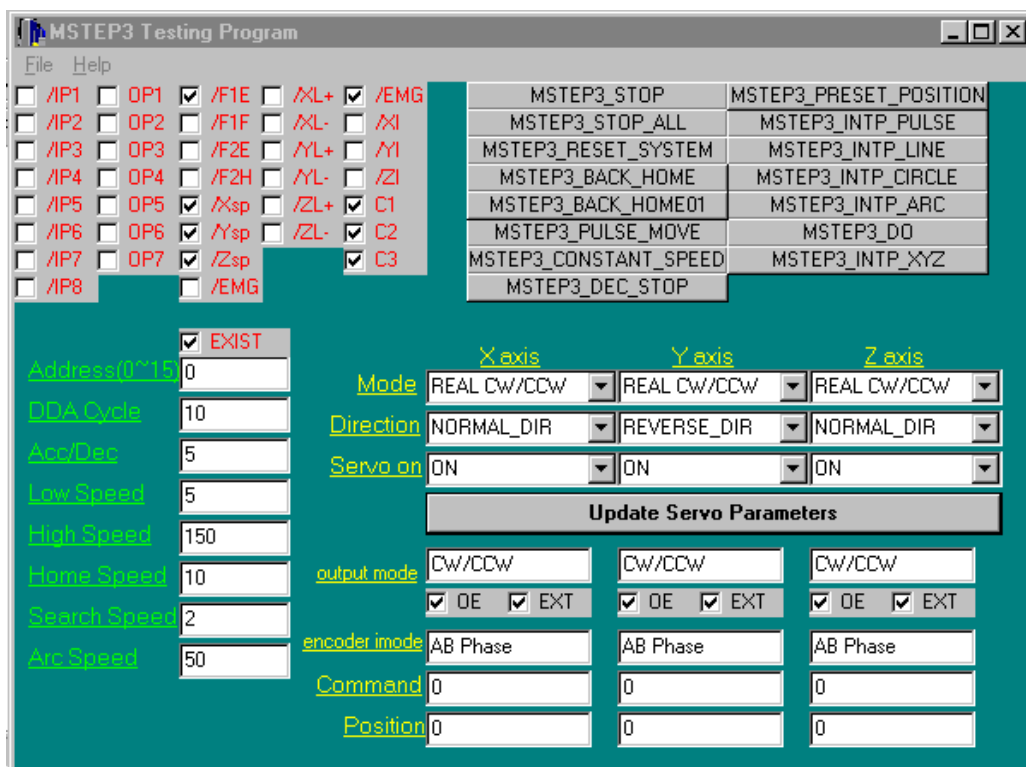

The panel of windows example

6. Application

The PISO-PS300(U) can be applied in X-Y table control, robot, CNC PCB driller, CNC PCB router, CNC wire cutter, lathe and semiconductor equipment.

For easily set up a machine, there is a daughter board DB-8R can be adopted. The DB-8R board is the connection board for limit switches, digital inputs/outputs.

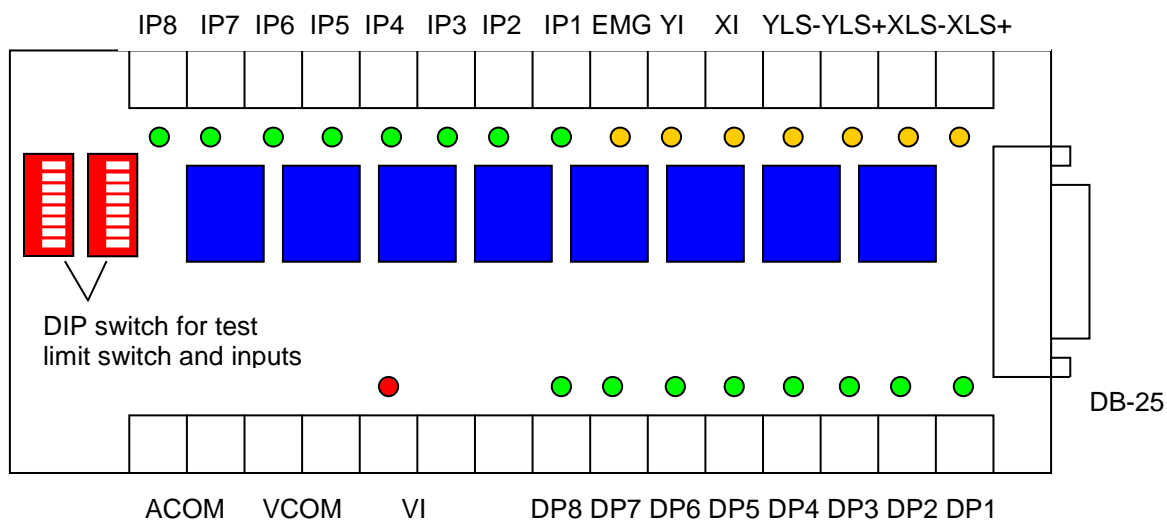

The DB-8R daughter board

6.1 Functional testing

If the user wants to verify the hardware and the function of PISO-PS300(U), it can run the bcmstep3.exe in windows95/98 or windows NT. The control panel will show in the screen as following.

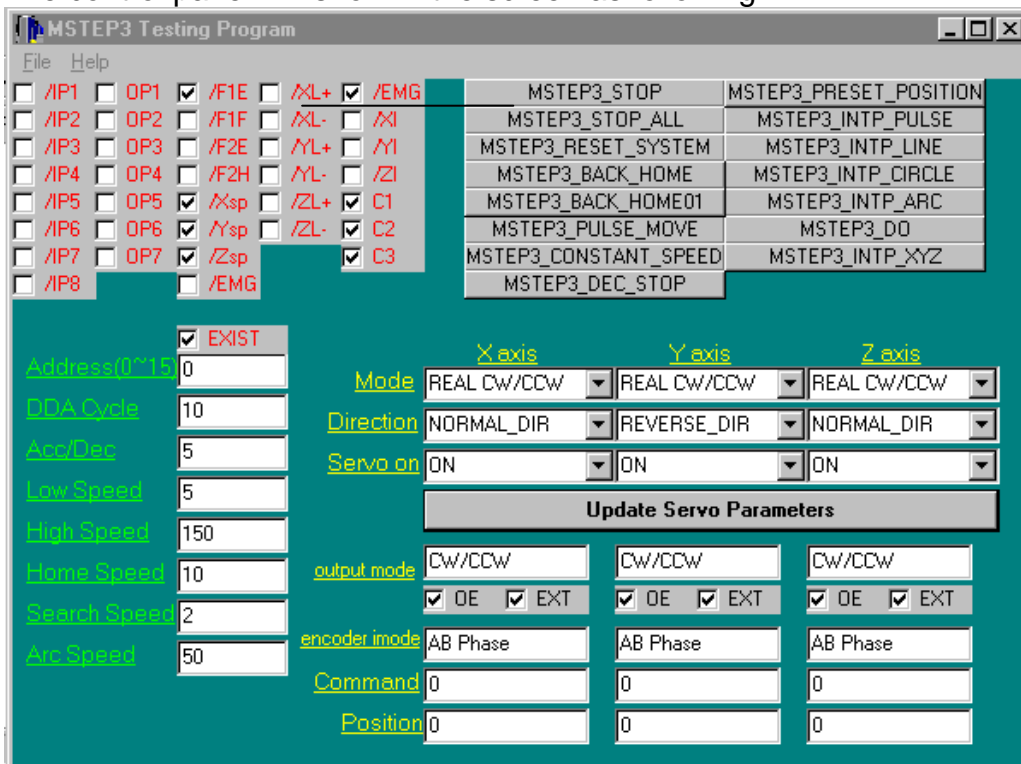

For easily test, the hardware connect as the following diagram.

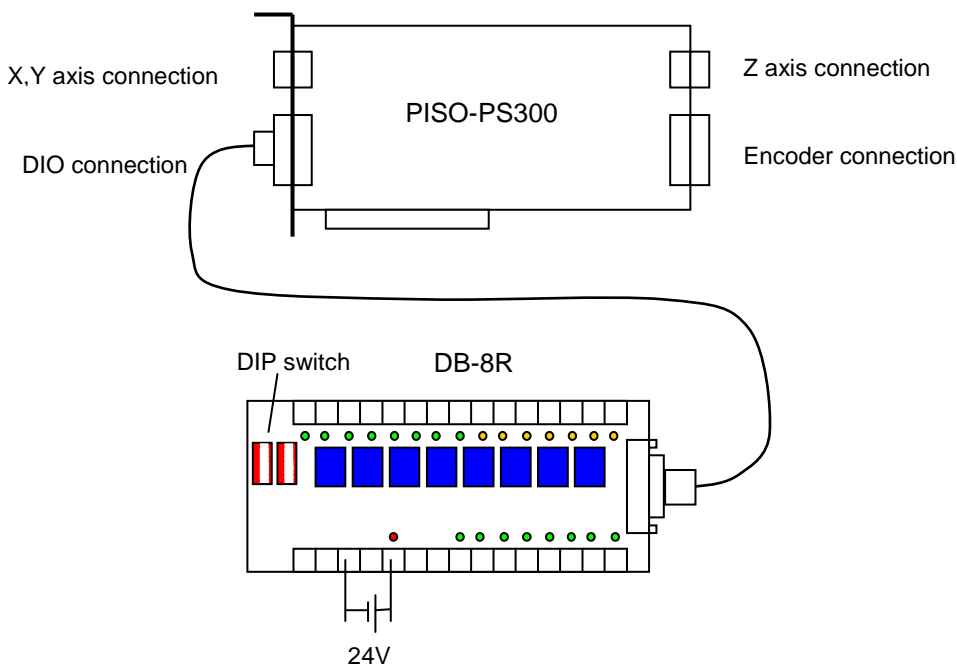

- **Check the PISO-PS300(U) card is exist or not**
The indicator “EXIST” will show the PISO-PS300(U) card is exist or not. In case of the card is not exist, all of the function will not be able to be perform.
- **Test digital inputs and limit switches**
First of all, the external power +24V shall be applied. While turn on the DIP switch on DB-8R daughter board, the corresponding LED on DB-8R and indicator in the control panel will turn on.
- **Test digital outputs**
First of all, the external power +24V shall be applied. The user can press the button **MSTEP3_DO**, and turn on the DO then press OK button, the corresponding DO LED on DB-8R will light.
- **Test encoder input**
The user can use a encoder or servo motor to test this item. It just connect the A+,A-,B+,B-,C+,C-,5V and GND to the PISO-PS300(U), and then rotate the encoder or motor’s shaft by manual. The position will be shown on the panel. The index C also will be shown on panel when rotate slowly.
- **Test pulse output**
Using the command **MSTEP3_CONSTANT_SPEED**, the PISO-PS300(U) will outputs the pulses on the pins CW_PULSE1 and CCW_DIR1. User can use these pin to drive the stepping motor or servo motor. User also can use logic probe or scope to check it.
- **Test servo on signal**
The servo ON/OFF switch right in the parameter area on the panel. The user can select ON or OFF, and press the update parameter button, the corresponding SON will act.
- **Test motion command in simulation mode**
First of all, select the **SIMU** mode and then press the update parameter button. The user can execute the motion command such as **MSTEP3_PULSE_MOVE**. The simulated position will show on the control panel.

6.2 Hand wheel input

```
//-----
// DEMO1.cpp                      12/11/99
//
// Function:
//  hand wheel(encoder) input from Z axis,
//  then move X axis
//-----

#include <math.h>
#include <stdio.h>
#include <stdlib.h>
#include <conio.h>
#include <dos.h>
#include <bios.h>
#include "mstep3.h"

//---- define -----
#define CARD1 0

//---- structure -----
typedef struct
{
  //---- parameter -----
  unsigned int  address;
  unsigned char exist;
  unsigned char DDA;
  unsigned char AD;
  unsigned int  LSP;
  unsigned int  HSP;
  unsigned char home_speed;
  unsigned char search_speed;
  unsigned int  arc_speed;

  unsigned char x_mode;
  unsigned char x_dir;
  unsigned char x_son;
  unsigned char y_mode;
  unsigned char y_dir;
```



```

unsigned char y_son;
unsigned char z_mode;
unsigned char z_dir;
unsigned char z_son;

//---- information -----
unsigned char op;
unsigned char ip;
unsigned char msc;
unsigned char ls;
unsigned char p1;
unsigned char x_state;
unsigned char y_state;
unsigned char z_state;
long      XC;
long      XP;
long      YC;
long      YP;
long      ZC;
long      ZP;
}CardParameter;

//---- variable -----
CardParameter card1;
long new_z,old_z;
char GetPosition;

//-----
#define INTR 0x08          //timer interrupt number
#define sampling_time 2982 //<1193180Hz>/2982=Hz(2.5ms)
unsigned long sampling_counter1=0;
void interrupt sampling_ISR(...);
void interrupt (*old_handler)(...);

//-----
// set timer interrupt period as 2.5ms,
// and set the vector of INTR=0x08 as user's program address
//-----

```

```

void set_timer()
{
  disable();
  old_handler = getvect(INTR);
  setvect(INTR, sampling_ISR);
  outp(0x43, 0x34);          //modify timer
  outp(0x40, sampling_time & 0x00ff);
  outp(0x40, (sampling_time >> 8) );
  outportb(0x20,0x20);
  enable();
}
//-----
// recover the vector of INTR=0x08,
// reset the timer
//-----
void release_timer()
{
  disable();
  outp(0x43, 0x34);
  outp(0x40, 0x00);
  outp(0x40, 0x00);
  setvect(INTR, old_handler);
  outportb(0x20,0x20);
  enable();
}
//-----
// Timer interrupt
// 1. trigger the original vector of INTR=0x08 by 18.Hz
// 2. get the PISO-PS300(U) information and status
//-----
void interrupt sampling_ISR(...) // 2.5ms sample once
{
  disable();
  sampling_counter1 += sampling_time;
  if (sampling_counter1>65536L)
  {
    sampling_counter1-=65536L;
    old_handler();      //trigger original 0x08h (18.Hz)
  }
}

```

```

};

//----- get card 1 information -----
if (card1.exist==YES)
{
    card1.ip = MSTEP3_DI(CARD1);
    card1.msc = MSTEP3_MSC(CARD1);

    MSTEP3_GET_CARD(CARD1);
    card1.ls =MSTEP3_GET_LIMIT(CARD1);
    card1.p1 =MSTEP3_GET_P1(CARD1);
    card1.XC =MSTEP3_GET_XC(CARD1);
    card1.XP =MSTEP3_GET_XP(CARD1);
    card1.YC =MSTEP3_GET_YC(CARD1);
    card1.YP =MSTEP3_GET_YP(CARD1);
    card1.ZC =MSTEP3_GET_ZC(CARD1);
    card1.ZP =MSTEP3_GET_ZP(CARD1);
}

GetPosition=1;
outportb(0x20,0x20);
enable();
}
//-----
// set the operation parameter of PISO-PS300(U)
//-----
void set_parameter()
{
    MSTEP3_SET_NC(CARD1,NO);
    MSTEP3_SET_CONTROL_MODE(CARD1, card1.x_mode,
card1.y_mode, card1.z_mode);
    MSTEP3_SET_VAR(CARD1, card1.DDA, card1.AD, card1.LSP,
        card1.HSP, card1.arc_speed);
    MSTEP3_SET_DEFDIR(CARD1, card1.x_dir, card1.y_dir, card1.z_dir);
    MSTEP3_SET_SERVO_ON(CARD1, card1.x_son, card1.y_son,
card1.z_son);
}
#####

```

```

void main()
{
char ch;

disable();
clrscr();

//-----set card 1 parameters-----
card1.address    = 0;   //0~15
card1.DDA        = 10;
card1.AD         = 5;
card1.LSP        = 5;
card1.HSP        = 150;
card1.home_speed = 10;
card1.search_speed = 2;
card1.arc_speed  = 50;

card1.x_mode     = DDA_CW_CCW|DDA_EN|DDA_OE|
                  ENC_AB_PHASE|ENC_EXTERNAL;
card1.x_dir      = NORMAL_DIR;
card1.x_son      = ON;
card1.y_mode     = DDA_CW_CCW|DDA_EN|DDA_OE|
                  ENC_AB_PHASE|ENC_EXTERNAL;
card1.y_dir      = NORMAL_DIR;
card1.y_son      = OFF;
card1.z_mode     = DDA_CW_CCW|DDA_EN|DDA_OE|
                  ENC_AB_PHASE|ENC_EXTERNAL;
card1.z_dir      = NORMAL_DIR;
card1.z_son      = OFF;

//---- check PISO-PS300/S300 is exist or not -----
card1.exist=MSTEP3_REGISTRATION(CARD1, card1.address);
if (card1.exist!=YES)
{
    printf("There is not exist any PISO-PS300/S300 card !");
    return;
}
MSTEP3_RESET_SYSTEM(CARD1);

```

```
clrscr();

//-----
set_timer();
set_parameter();
enable();
GetPosition=0;

do {} while (GetPosition=0);
new_z=card1.ZP;
old_z=new_z;
do{
    card1.msc=MSTEP3_MSC(CARD1);    //get msc register
    if ((card1.msc & 0x01)== 0x00)    //check FIFO1 is empty or not!
    {
        new_z=card1.ZP;
        //output the difference of Z-axis to X-axis
        MSTEP3_INTP_PULSE(CARD1,new_z-old_z,0,0);
        old_z=new_z;
    }
    gotoxy(1,10);
    printf("HandWheel Z=%10ld, X output=%10ld", new_z, card1.XC);
} while (bioskey(1)==0);

MSTEP3_RESET_SYSTEM(CARD1);
release_timer();
}
```

7. PISO-PS300U new function

1. (11/3/2011) When the motor driver used 12V. The PISO-PS300 need to remove the resistor. The PISO-PS300U provides the switch used to remove the resistor easily.

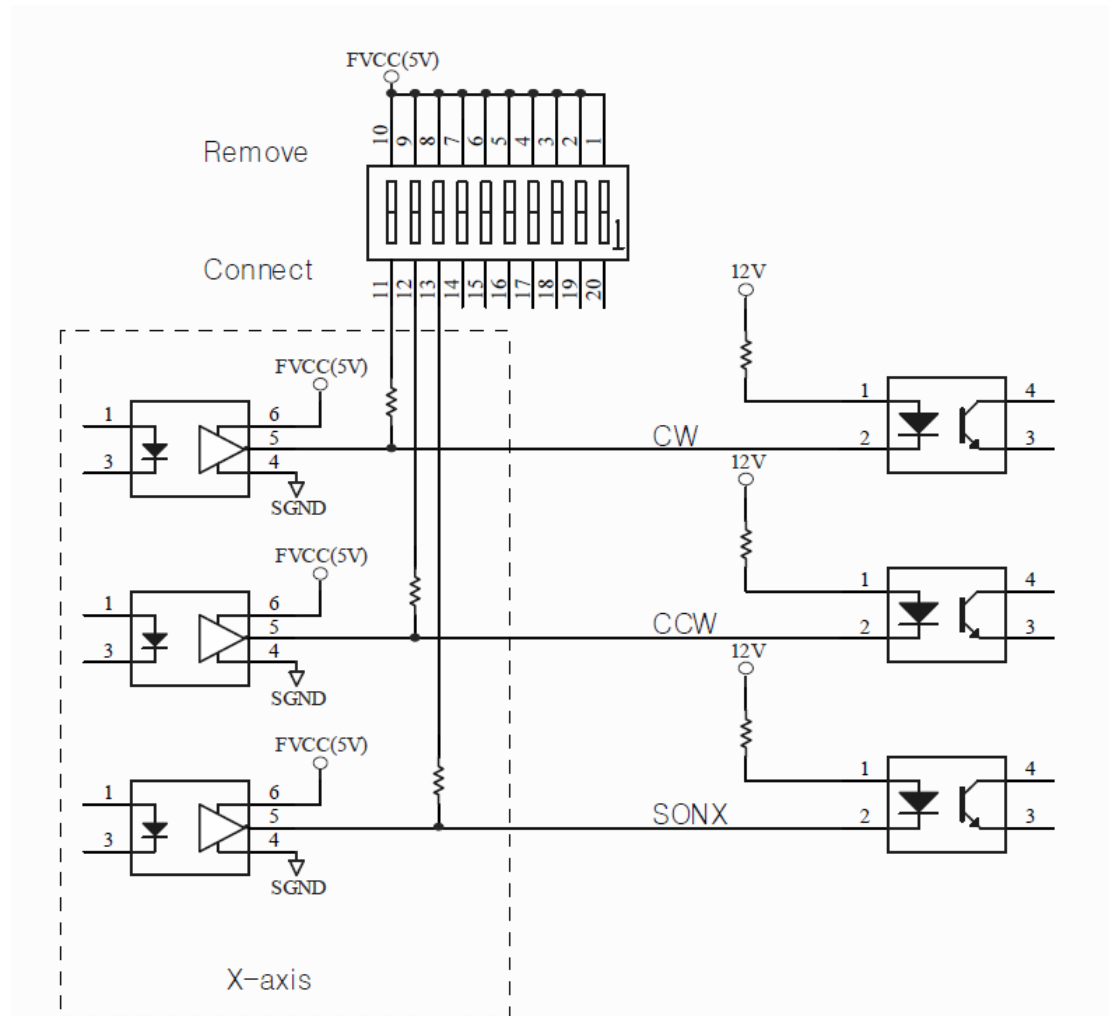

12 V motor driver connection

