

# CAN-2015C Quick Start

## Hardware Specification

<b>CAN Interface</b>	
CANopen Specification	CiA DS-301 v4.02, DS-401 v2.1
No. of PDOs	10 Rx, 10 Tx (Support dynamic PDO)
PDO Mode	Event-triggered, Remotely-requested, Cyclic and acyclic SYNC
Node ID	1~99 selected by rotary switch
Baud Rate (bps)	10k, 20k, 50, 125k, 250k, 500k, 800k and 1M
Error Control	Node Guarding protocol and Heartbeat Producer protocol
Terminator Resistor	Switch for 120 $\Omega$ terminator resistor
Connector	5-pin screwed terminal block (CAN_GND, CAN_L, CAN_SHLD, CAN_H, CAN_V+)
<b>Analog Input</b>	
Channels	8 channels for 2-wire or 3-wire RTD
Input Type	Pt100, Pt1000, Ni120, Cu100, Cu1000, JPt100
Resolution	16-bit
Sampling Rate	10 Samples/ sec (Total)
Accuracy	+/-0.1% FSR
Zero Drift	+/-0.5 $\mu$ V/ $^{\circ}$ C
Span Drift	+/-20ppm/ $^{\circ}$ C
Common Mode Rejection	150dB
Normal Mode Rejection	100dB
Input Impedance	20M $\Omega$
Intra-module Isolation	3000 Vrms
ESD Protection	+/-4 kV, Contact for each channel
<b>LED</b>	
Status LED	PWR LED, RUN LED, ERR LED
Terminal Resister LED	Terminal Resister Indicator
<b>Power</b>	
Input range	Unregulated +10 ~ +30 V <sub>DC</sub>
Power Consumption	1.5 W
<b>Environment</b>	
Operating Temp.	-25 ~ 75 $^{\circ}$ C
Storage Temp.	-30 ~ 80 $^{\circ}$ C
Humidity	10 ~ 90% RH, non-condensing

For more information about CAN-2015C, please visit the following website:  
[http://www.icpdas.com/products/Remote\\_IO/can\\_bus/can-2015c.htm](http://www.icpdas.com/products/Remote_IO/can_bus/can-2015c.htm)

# CAN-2015C Pin Assignments

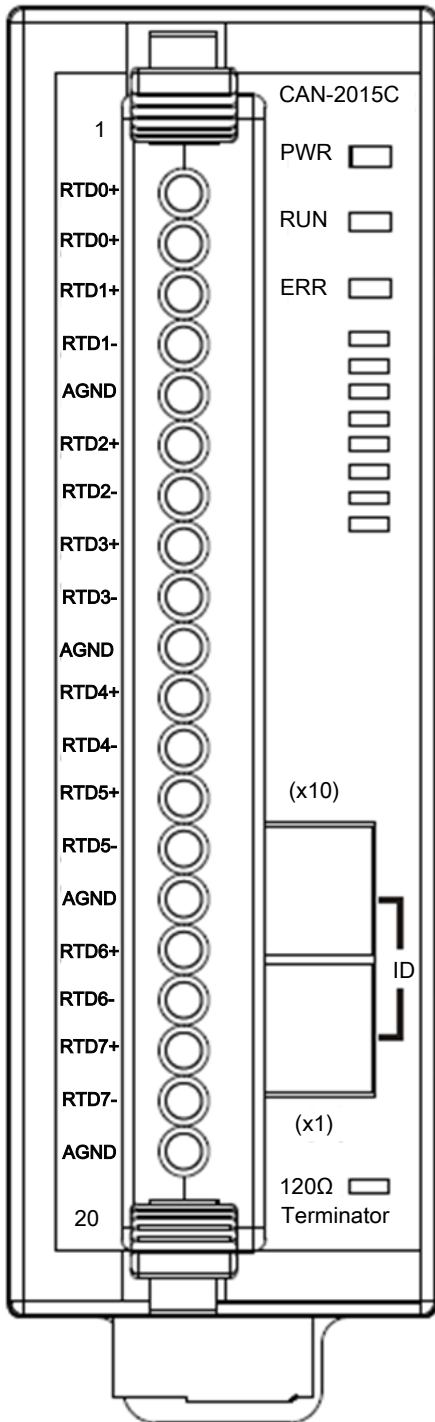

Terminal No.	Pin Assignment
01	A0
02	B0
03	A1
04	B1
05	GND
06	A2
07	B2
08	A3
09	B3
10	GND
11	A4
12	B4
13	A5
14	B5
15	GND
16	A6
17	B6
18	A7
19	B7
20	GND

## CAN-2015C Internal I/O Structure

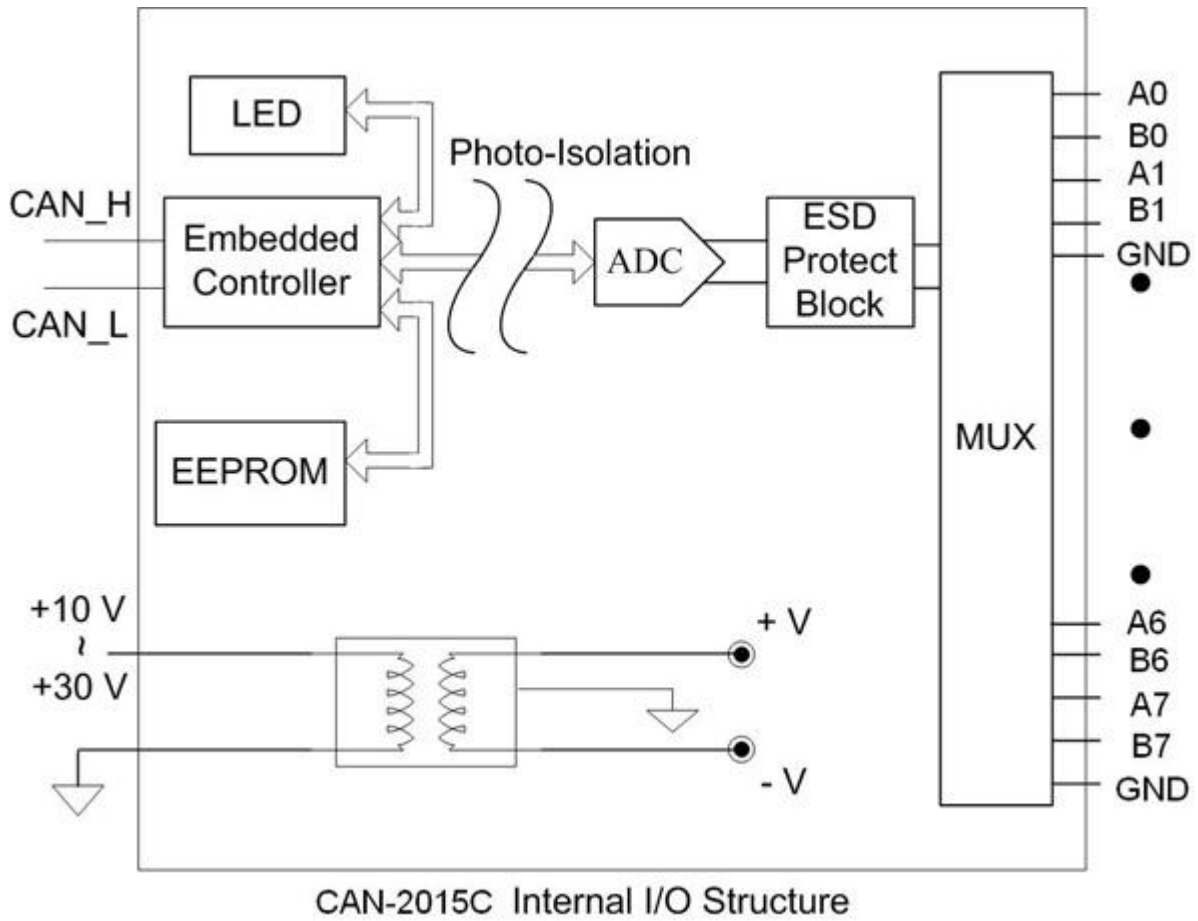

## CAN-2015C Wiring Connection Type

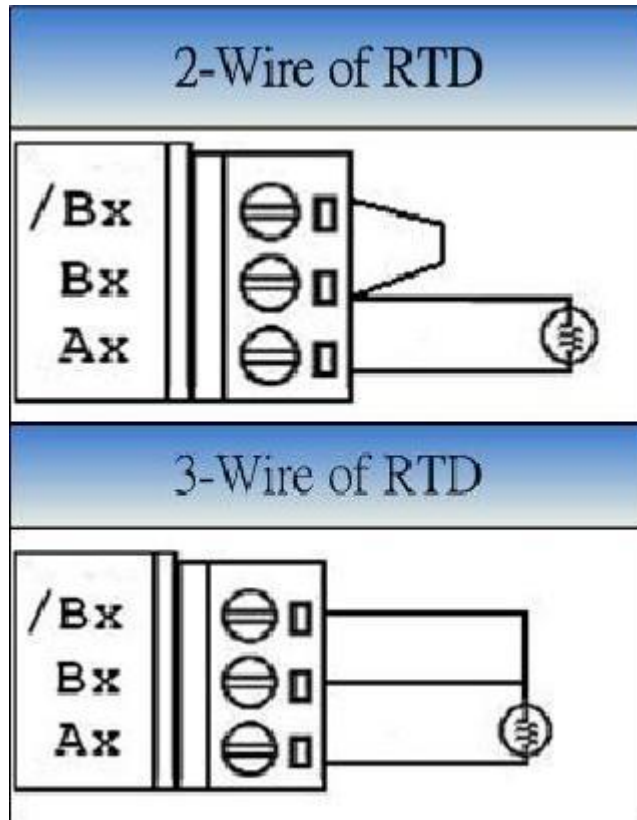

**Note:** When connecting to a current source, an optional external 125-Ohm precision resistor is required.

## CAN-2015C CAN Bus Wire Connection

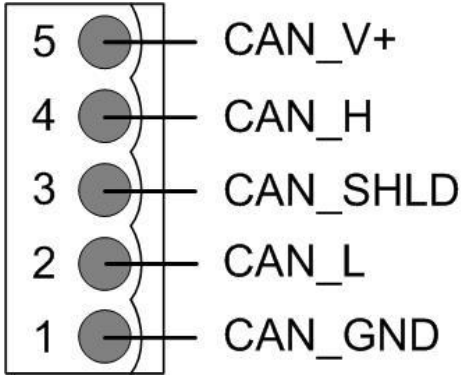

Pin	Signal	Description
5	CAN_V+	Power positive
4	CAN_H	Signal high of CAN Bus line
3	CAN_SHLD	Cable Shield ( <b>FG</b> )
2	CAN_L	Signal low of CAN Bus line
1	CAN_GND	CAN ground

\* CAN\_SHID (FG) is Optional.

### 2-Wire Connection

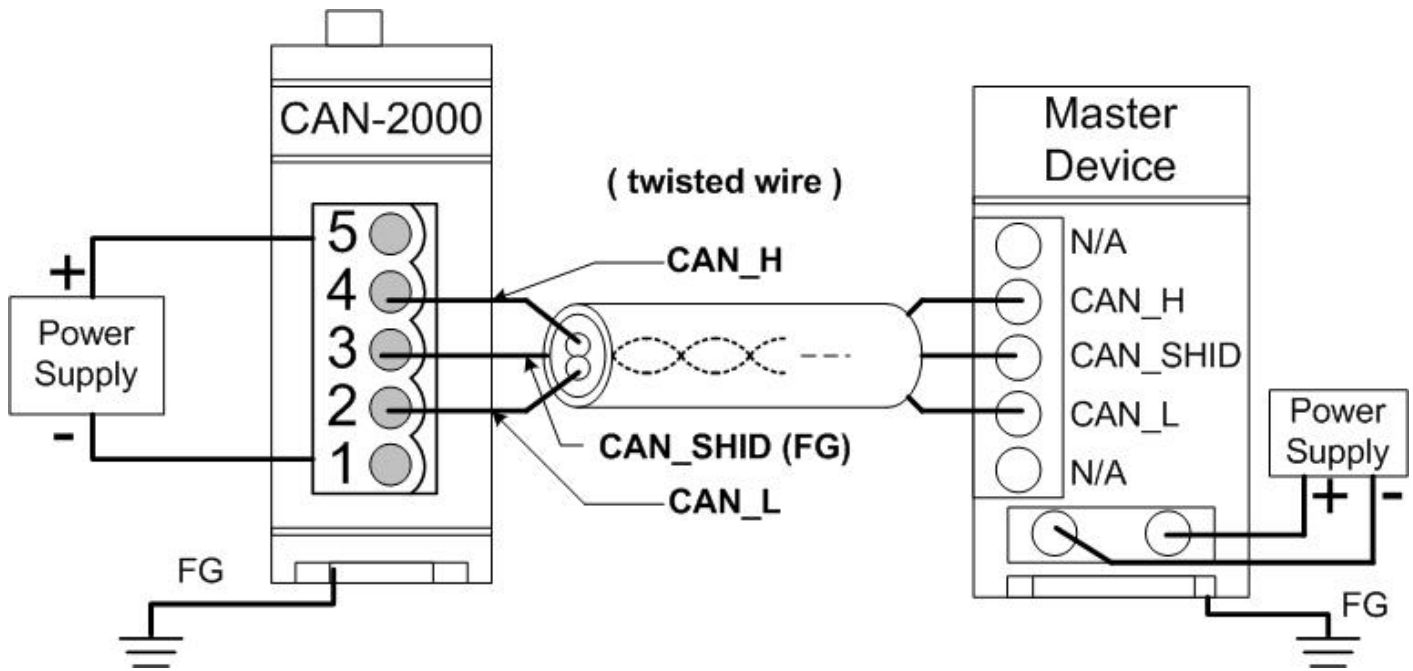

### 3-Wire Connection

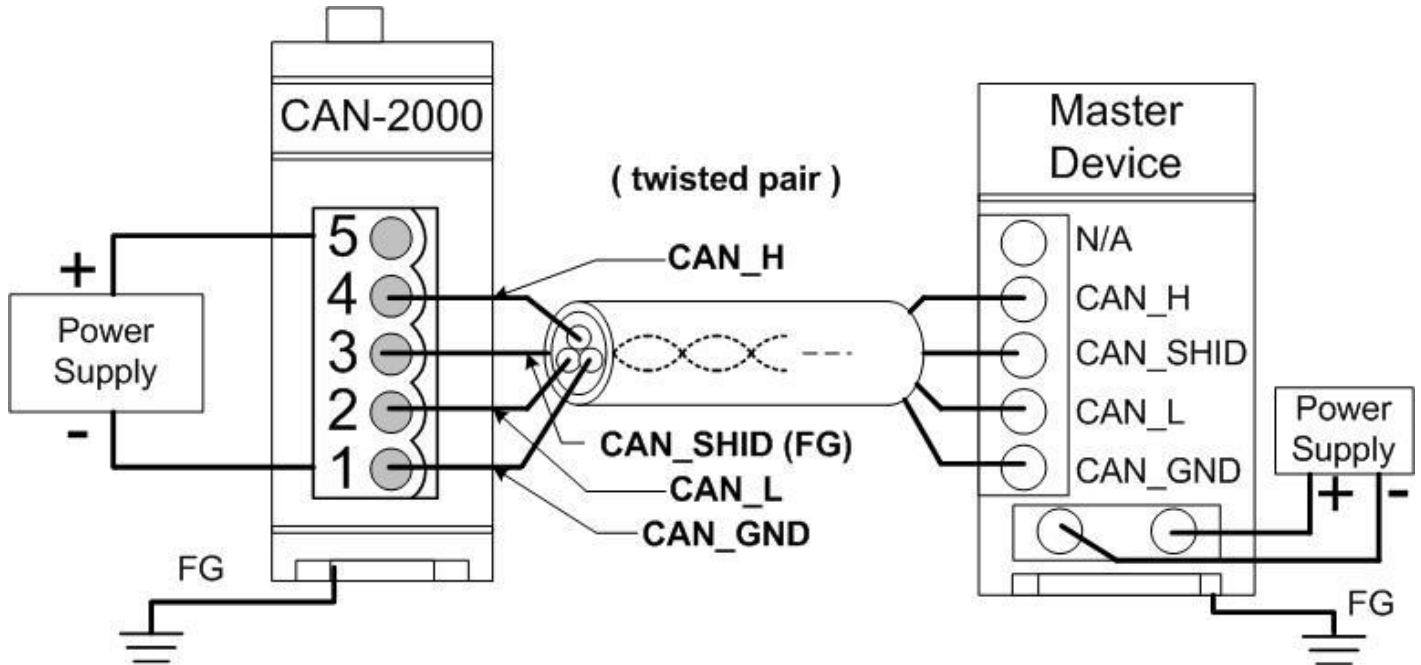

### 4-Wire Connection (The CAN-2000 is powered by the master device)

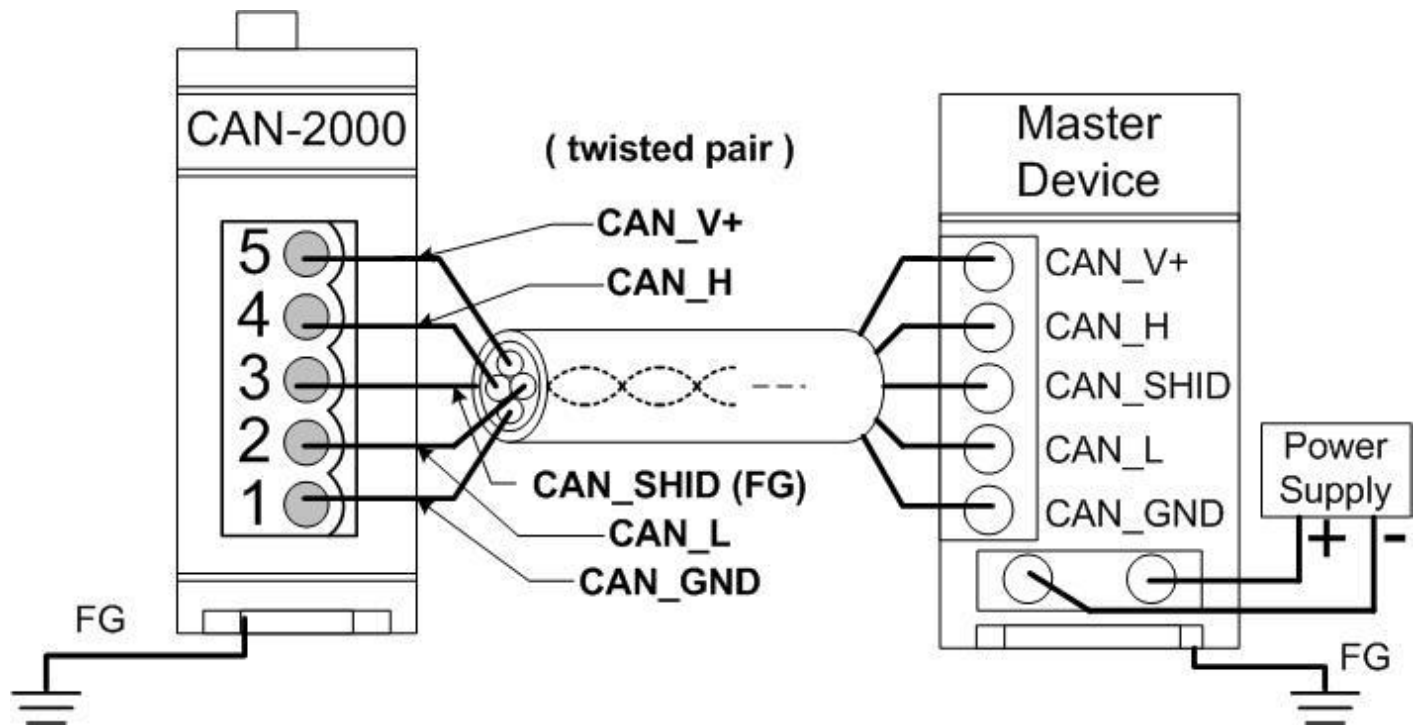

## CAN-2015C Firmware Update

**Step 1 – Set Module to “Bootloader” mode (set Node ID to 00). Then power on the module.**

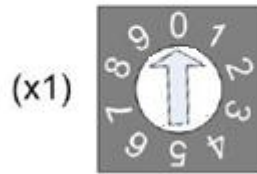
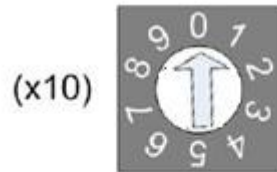

**Node ID rotary switch**

**Step 2 – Run FW\_Update\_CAN Utility**

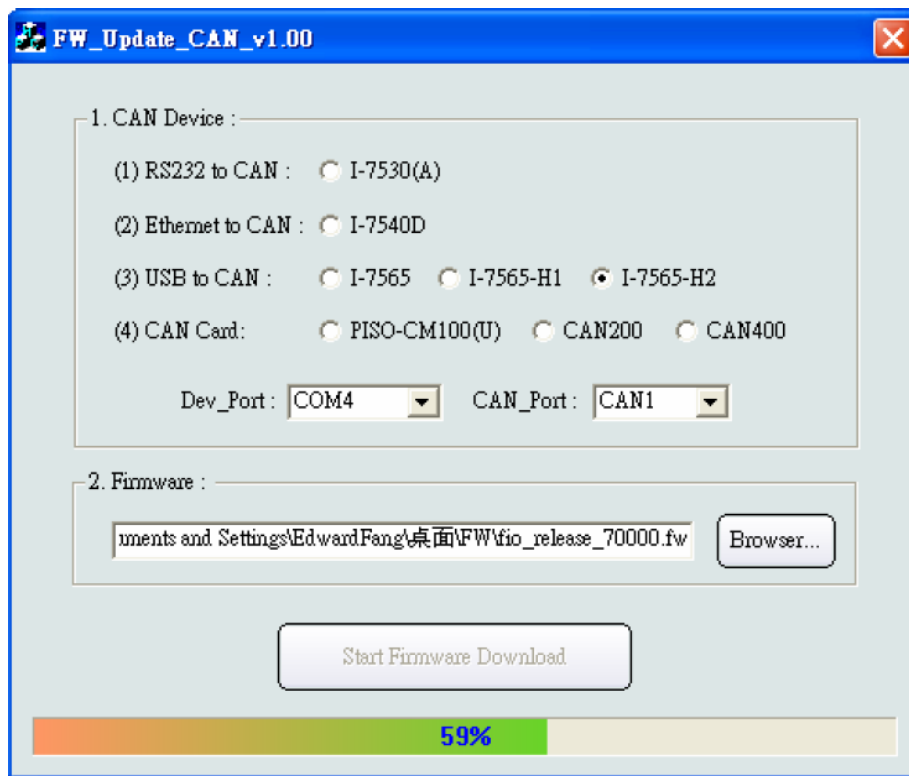

**( FW\_Update\_CAN Utility )**

## [1] CAN Device :

The below ICP DAS CAN products are supported by FW\_Update\_CAN utility for firmware update.

- (1) RS232 to CAN : I-7530
- (2) Ethernet to CAN : I-7540D
- (3) USB to CAN : I-7565, I-7565-H1, I-7565-H2
- (4) CAN Card : PISO-CM100(U),  
PISO-/PCM-/PEX-CAN200 / CAN400

Before firmware update, users need to set the below parameters.

- (1) Select CAN hardware interface
- (2) set Dev\_Port or Board\_ID
- (3) set CAN\_Port” number

## [2] Download Firmware :

- (1) Click “**Browser...**” button to choose firmware file, can\_2015c\_xx.fw.
- (2) Click “**Start Firmware Update**” button to start firmware update and it will show the total percentage of firmware update in progress bar. After the firmware update finished, it will show the “Firmware Update Success !!” message.



CAN-2015C firmware Download:

[ftp://ftp.icpdas.com/pub/cd/fieldbus\\_cd/canopen/slave/can-2000c/can-2015c/](ftp://ftp.icpdas.com/pub/cd/fieldbus_cd/canopen/slave/can-2000c/can-2015c/)

FW\_Update\_CAN Utility Download:

[ftp://ftp.icpdas.com/pub/cd/fieldbus\\_cd/canopen/slave/can-2000c/tools/](ftp://ftp.icpdas.com/pub/cd/fieldbus_cd/canopen/slave/can-2000c/tools/)