

# CAN-2026C Quick Start

## Hardware Specification

<b>CAN Interface</b>	
CANopen Specification	CiA-301 v4.02, CiA -401 v2.1
No. of PDOs	10 Rx, 10 Tx (Support dynamic PDO)
PDO Mode	Event-triggered, Remotely-requested, Cyclic and acyclic SYNC
Node ID	1~99 selected by rotary switch
Baud Rate (bps)	10k, 20k, 50, 125k, 250k, 500k, 800k and 1M
Error Control	Node Guarding protocol and Heartbeat Producer protocol
Terminator Resistor	Switch for 120 Ω terminator resistor
Connector	5-pin screwed terminal block (CAN_GND, CAN_L, CAN_SHLD, CAN_H, CAN_V+)
<b>Analog Input</b>	
Channels	6
Input Type	+/- 10V, +/- 5V, +/- 1V, +/- 500mV, +/- 150mV -20mA ~ +20mA(Requires Optional External 125Ω Resistor)
Resolution	16-bit
<b>Analog Output</b>	
Channels	2
Output Type	+0V ~ +5V, +/-5V, +0 V ~ +10V,+/-10V
Resolution	12-bit
<b>Digital Input</b>	
Channels	2
Input Type	Sink
<b>Digital Output</b>	
Channels	1
Output Type	Sink
<b>LED</b>	
Status LED	PWR LED, RUN LED, ERR LED
Terminal Resister LED	Terminal Resister Indicator
<b>Power</b>	
Input range	Unregulated +10 ~ +30 V <sub>DC</sub>
Power Consumption	2.0 W
<b>Environment</b>	
Operating Temp.	-25 ~ 75 °C
Humidity	10 ~ 90% RH, non-condensing

For more information about CAN-2026C, please visit the following website:  
[http://www.icpdas.com/products/Remote IO/can bus/CAN-2026C.htm](http://www.icpdas.com/products/Remote_IO/can_bus/CAN-2026C.htm)

## CAN-2026C Pin Assignments

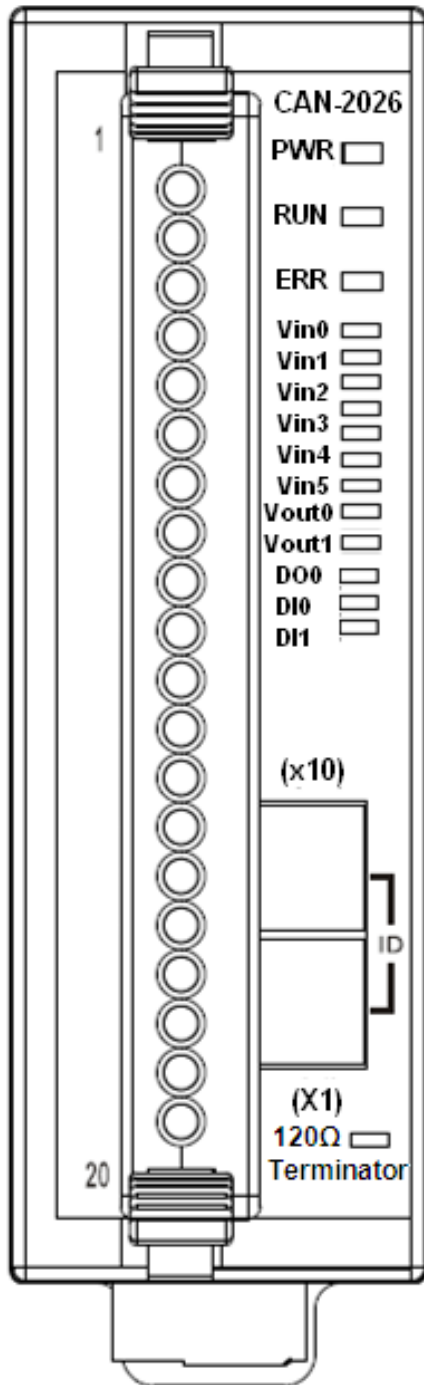

Terminal No.	Pin Assignment
01	Vin0+
02	Vin0-
03	Vin1+
04	Vin1-
05	Vin2+
06	Vin2-
07	Vin3+
08	Vin3-
09	Vin4+
10	Vin4-
11	Vin5+
12	Vin5-
13	Vout0+
14	Vout0-
15	Vout1+
16	Vout1-
17	DO0
18	DI0
19	DI1
20	COM

# CAN-2026C Internal I/O Structure

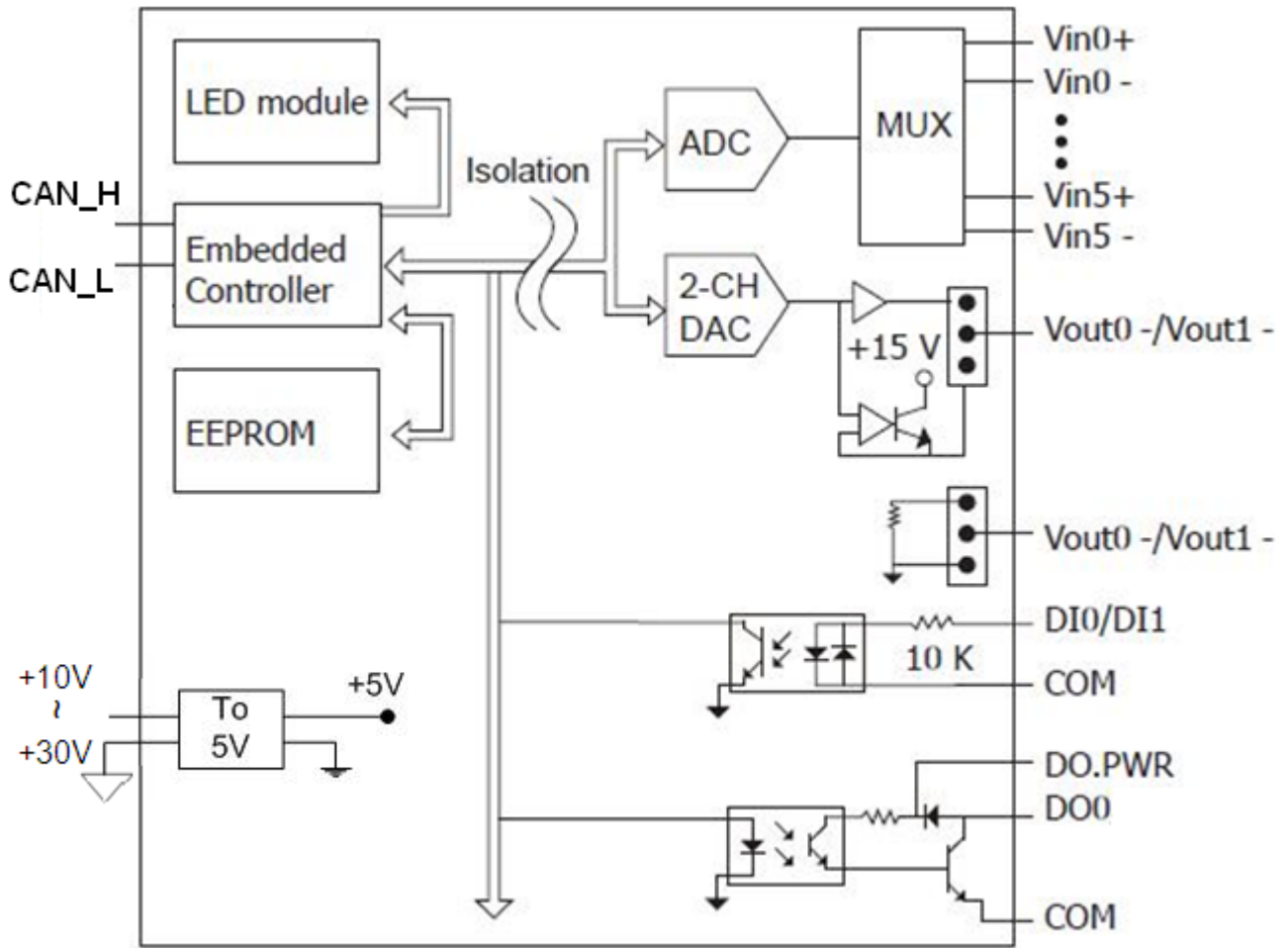

# CAN-2026C Wiring Connection Type

Voltage Input		
Current Input		
Voltage Output		
Digital Input/ Counter	ON State Readback as 1	OFF State Readback as 0
Wet Contact (Sink)		
Digital Output	ON State Readback as 1	OFF State Readback as 0
Open Collector (Sink)		

## CAN-2026C CAN Bus Wire Connection

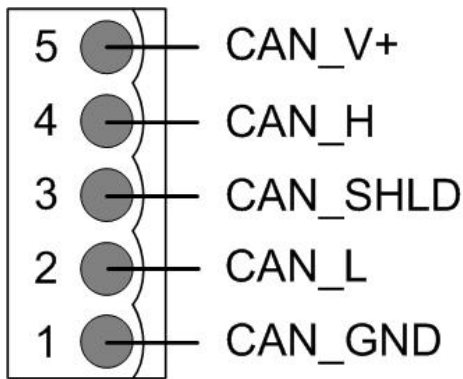

Pin	Signal	Description
5	CAN_V+	Power positive
4	CAN_H	Signal high of CAN Bus line
3	CAN_SHLD	Cable Shield ( <b>FG</b> )
2	CAN_L	Signal low of CAN Bus line
1	CAN_GND	CAN ground

\* CAN\_SHID (FG) is Optional.

### 2-Wire Connection

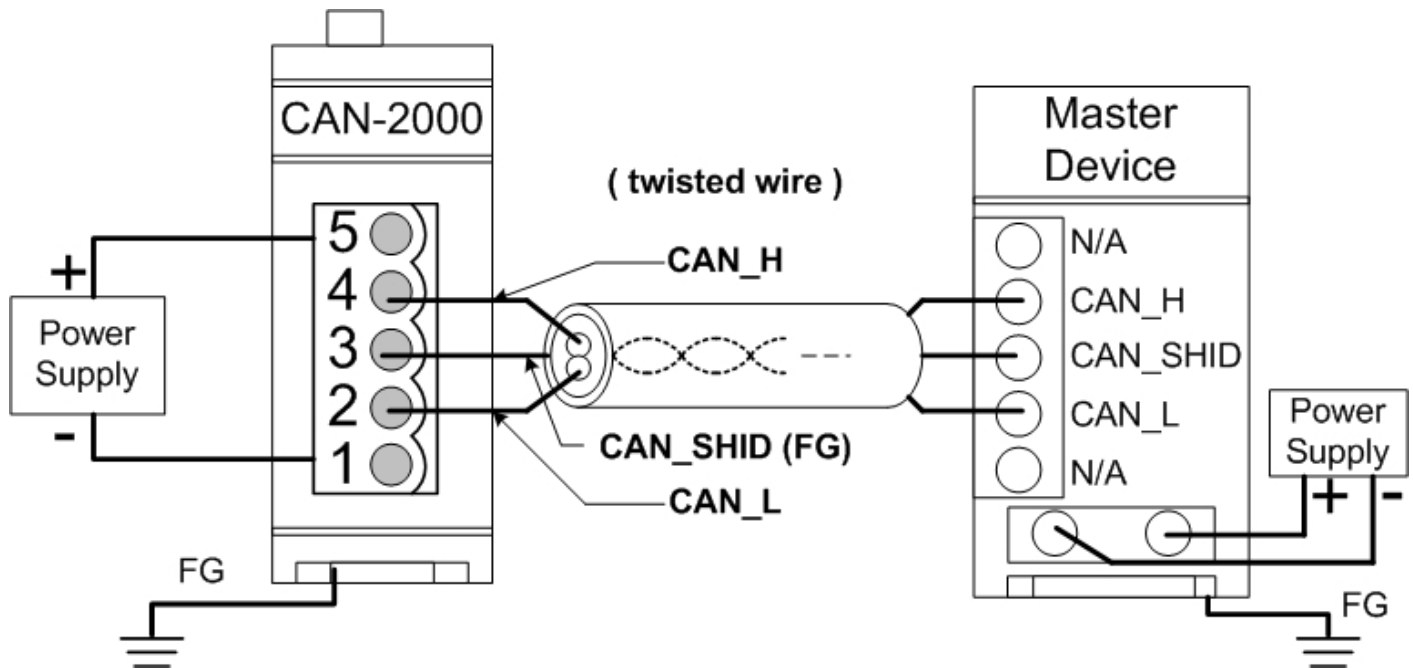

### 3-Wire Connection

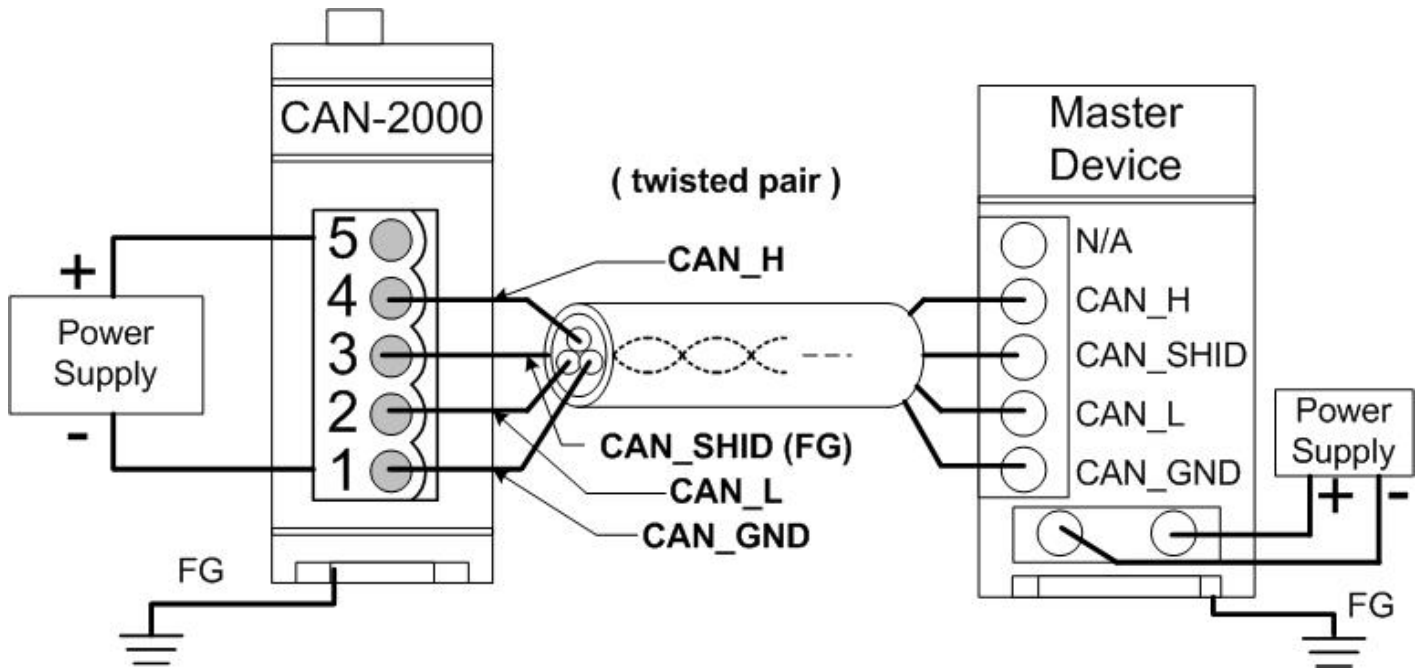

### 4-Wire Connection (The CAN-2000 is powered by the master device)

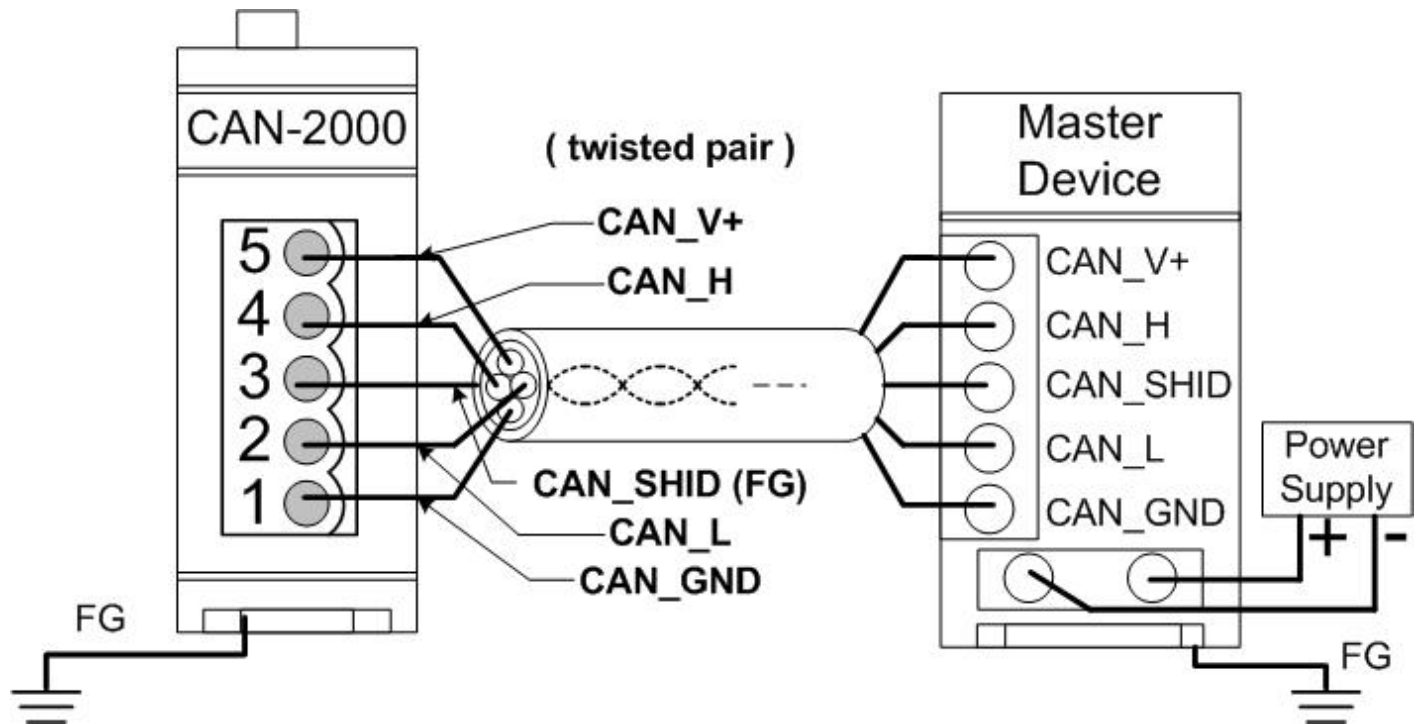

## CAN-2026C Firmware Update

**Step 1 – Set Module to “Bootloader” mode (set Node ID to 00, Baud rate to F). Then power on the module.**

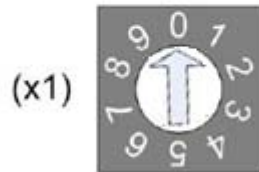
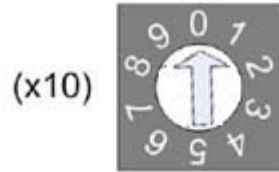

**Node ID rotary switch**

**Step 2 – Run FW\_Update\_CAN Utility**

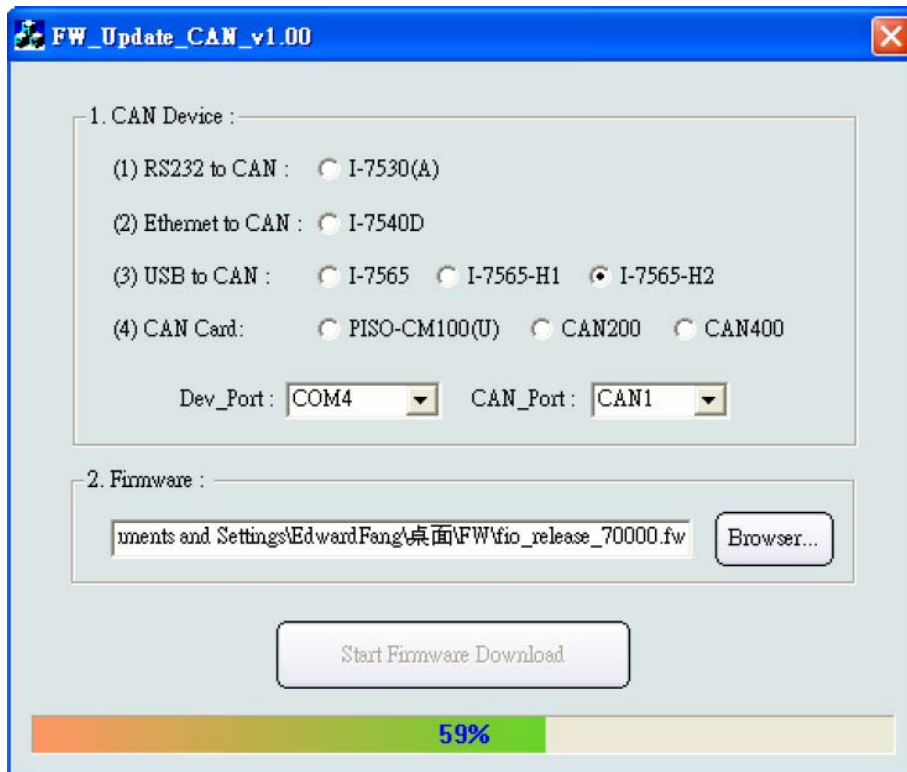

**( FW\_Update\_CAN Utility )**

## [1] CAN Device :

The below ICP DAS CAN products are supported by FW\_Update\_CAN utility for firmware update.

- (1) RS232 to CAN : I-7530
- (2) Ethernet to CAN : I-7540D
- (3) USB to CAN : I-7565, I-7565-H1, I-7565-H2
- (4) CAN Card : PISO-CM100(U),  
PISO-/PCM-/PEX-CAN200 / CAN400

Before firmware update, users need to set the below parameters.

- (1) Select CAN hardware interface
- (2) set Dev\_Port or Board\_ID
- (3) set CAN\_Port” number

## [2] Download Firmware :

- (1) Click “**Browser...**” button to choose firmware file, can\_2017c\_xx.fw.
- (2) Click “**Start Firmware Update**” button to start firmware update and it will show the total percentage of firmware update in progress bar. After the firmware update finished, it will show the “Firmware Update Success !!” message.



CAN-2026C firmware Download:

[ftp://ftp.icpdas.com/pub/cd/fieldbus\\_cd/canopen/slave/can-2000c/CAN-2026C/](ftp://ftp.icpdas.com/pub/cd/fieldbus_cd/canopen/slave/can-2000c/CAN-2026C/)

FW\_Update\_CAN Utility Download:

[ftp://ftp.icpdas.com/pub/cd/fieldbus\\_cd/canopen/slave/can-2000c/tools/](ftp://ftp.icpdas.com/pub/cd/fieldbus_cd/canopen/slave/can-2000c/tools/)