



GTM-203M-3GWA

Quick Start

1 Product Check List

The package includes the following items :

- One GTM-203M-3GWA hardware module
- One Quick Start (this manual)
- One companion CD
- One USB Type A to Type B connector cable (CA-USB18)
- One 2G/3G antenna (ANT-421-03)
- One GTM-203M-A audio module
- Screw Driver

2 Related Documents and Software

2.1 Documents

- User Manual : GTM-203M-3GWA_User's Manual
- Quick Start : GTM-203M-3GWA_QuickStart
- CD: \napdos\3g_modem\gtm-203m-3gwa>manual
- http://ftp.icpdas.com/pub/cd/usbcd/napdos/3g_modem/gtm-203m-3gwa/manual

2.2 USB Driver

- http://ftp.icpdas.com/pub/cd/usbcd/napdos/3g_modem/gtm-203m-3gwa/software/driver/

3 Hardware Installation

3.1 View of the GTM-203M-3GWA Panel

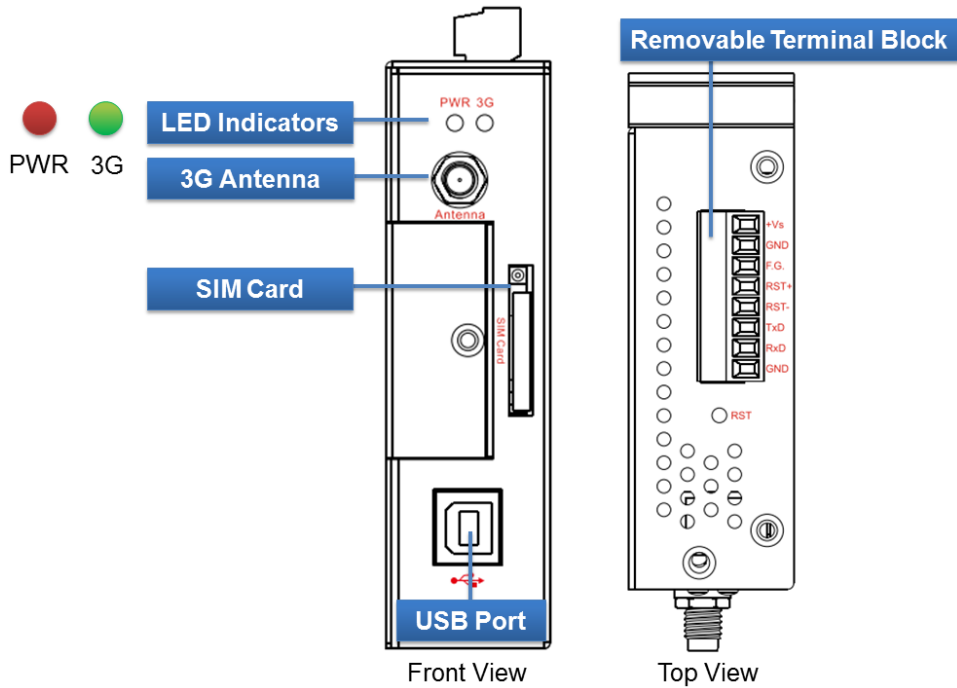

3.2 Pin Assignments

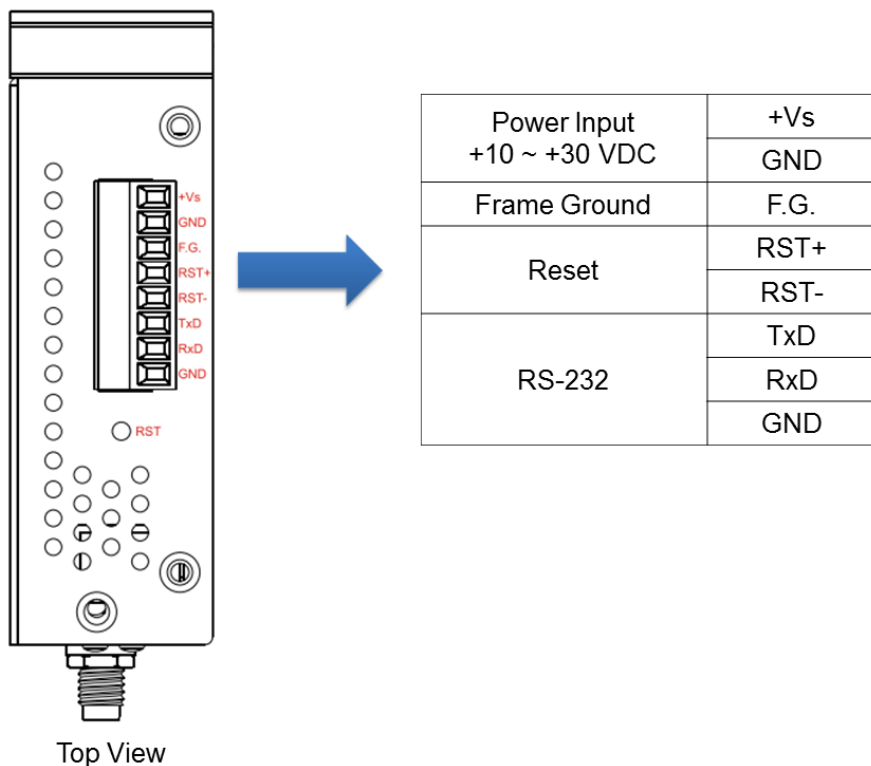

3.3 Installation



3.4 Reset Wire Connection

Input Type	Reset State ON	Reset State OFF
Reset Input		

Reset Input	
ON Voltage Level	+3.5 V _{DC} ~ +30 V _{DC}
OFF Voltage Level	+1 V _{DC} max.

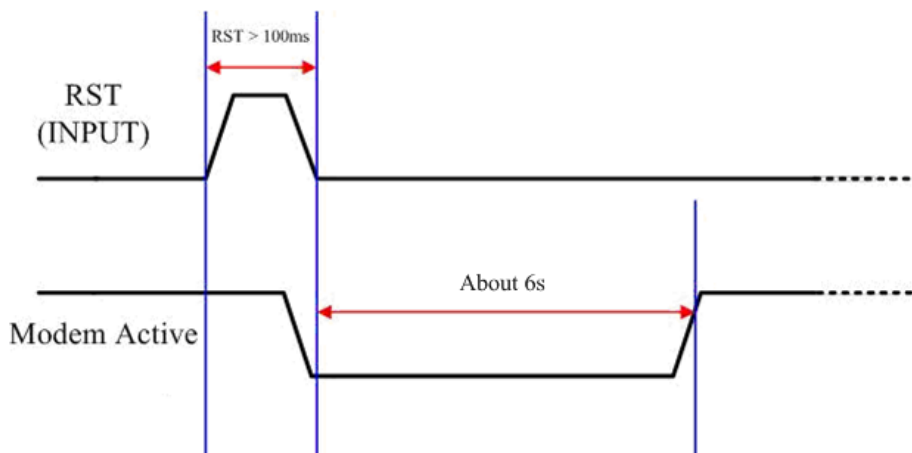

Timing of restarting the modem

4 USB Installation

Step 1: Double Click “GTM-203-3GWA USB driver V1.00.exe” to install the driver.

Step 2: Click “Next” until finishing installation.

Step 3: Connect the USB of GTM-203M-3GWA with the PC.

Step 4: The “Found New Hardware Wizard” window will pop-out. Please click “Next” until finishing installation.



Step 5: Finish the all install steps. Please open “Device manager”, and you will found new 8 items in your computer.

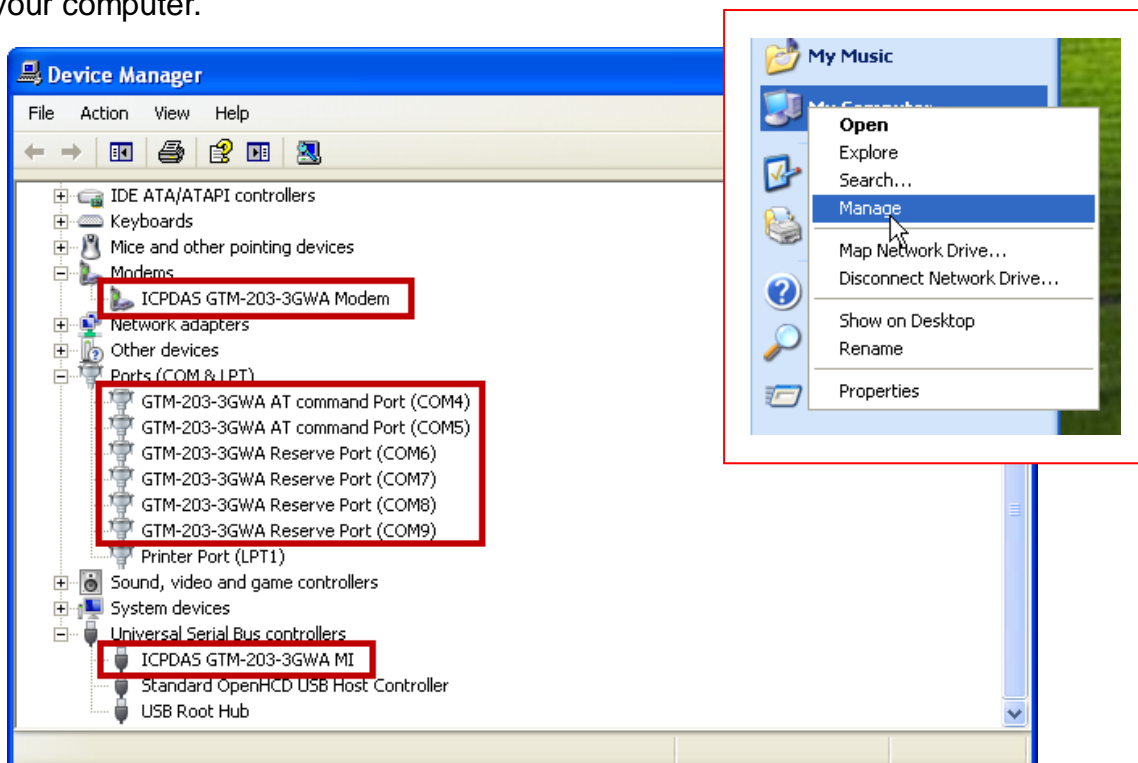

5 Quick Test

Step 1: Start → All Programs → Accessories → Communications → Hyper Terminal → Input new connection name → Click “OK” → Select “GTM-203-3GWA AT command Port” for USB or your PC serial port for RS-232 communication → Click “OK”

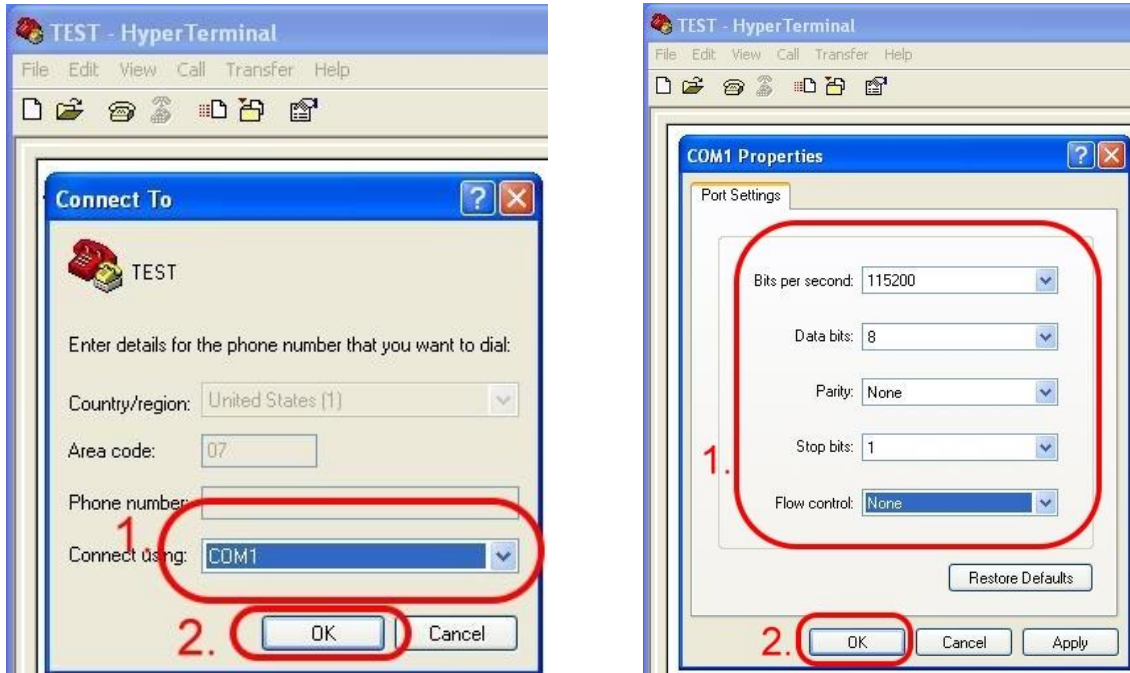

Step 2: File → Properties → Settings → Click “ASCII Setup...” → Select “Echo typed characters locally” → Click “OK”

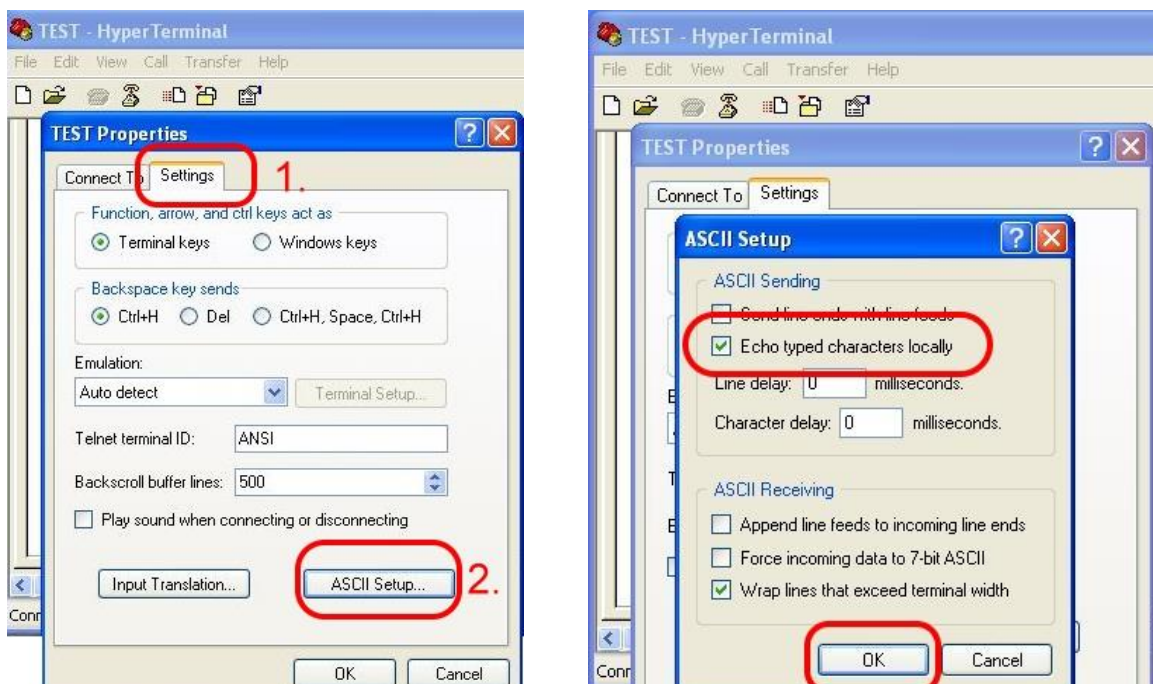

Step 3: Input “AT” and press “Enter”, then you will receive “AT OK”.

6 How to install GTM-203M-A

Step 1:

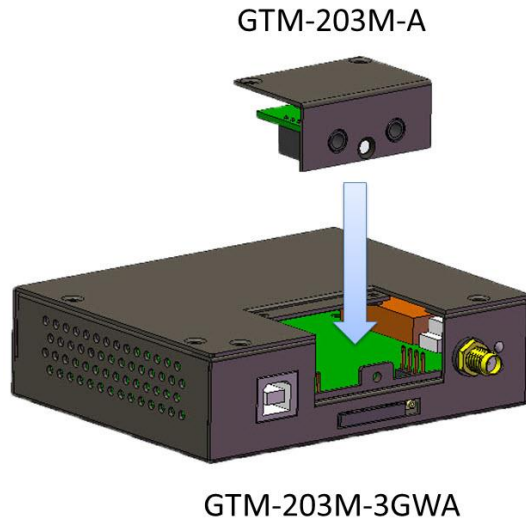

Step 2:



7 Technical Support

If you have problems about using the GTM-203M-3GWA, please contact ICP DAS product support.

Email : Service@icpdas.com

GTM-203M-3GWA website : <http://m2m.icpdas.com/gtm-203m-3gwa.html>