

HRT-710 Quick Start Guide

1. Introduction

The hardware wiring and detailed operation of HRT-710, users can refer to the user manual in the ICP DAS companion CD-ROM (CD:\hart\gateway\HRT-710>manual\HRT-710_usermanual.pdf).

The quick start is used to help users quickly understand HRT-710 how to convert Modbus communication to HART. The below demo will use a HRT-710 module (as HART master), one HART slave device and one PC to make a simple application as below Figure 1. The PC is prepared for the setting and operation of HRT-710.

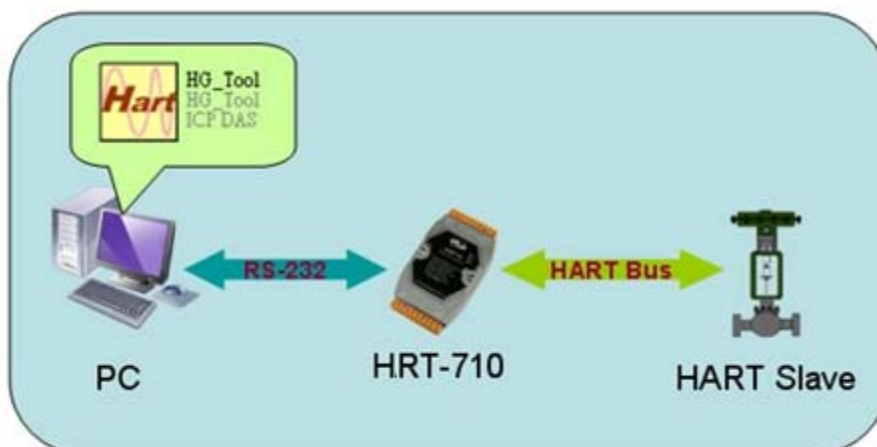
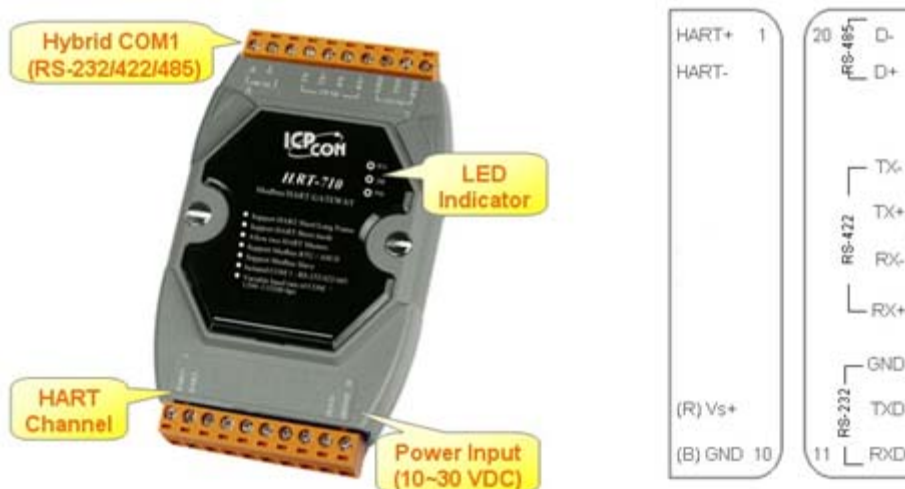

Figure 1: Application example

2. Hardware configuration

Pin Assignment:



Pin	Name	Description
1	HART+	Positive of HART
2	HART-	Negative of HART
3	-	N/A
4	-	N/A
5	-	N/A
6	-	N/A
7	-	N/A
8	-	N/A
9	+VS	V+ of Power Supply(+10 ~ +30 V _{DC})
10	GND	GND of Power Supply
11	TXD	Transmit Data of RS-232
12	RXD	Receive Data of RS-232
13	GND	GND of RS-232
14	RX+	Receive Data+ of RS-422
15	RX-	Receive Data- of RS-422
16	TX+	Transmit Data+ of RS-422
17	TX-	Transmit Data- of RS-422
18	-	N/A
19	D+	Data+ of RS-485
20	D-	Data- of RS-485

DIP Switch:

If user set the DIP switch in the backplane of HRT-710 to be “Default” position, HRT-710 will run in the default mode.



Jumper:

The pins 1&2 of JP4 is closed by default and the 250 Ω (1/4 W) resistor will connect to HART network by default.

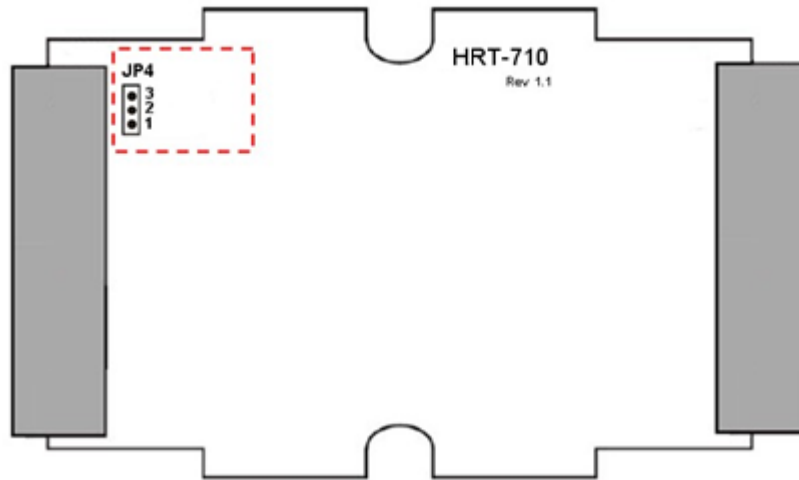

LED Indicator:



LED Name	Status	Description
PWR	on	Power supply is ok.
	off	Power supply has failed.
ERR	flash	Communication error
	off	No error
RUN	flash	Flash once about 1 s: HRT-710 in initial mode. Flash once about 500 ms: HRT-710 received the burst frame.
	on	HRT-710 in operation mode.

LED Name	Status	Description
	off	HRT-710 firmware has not been loaded yet.

RS-232 connection:

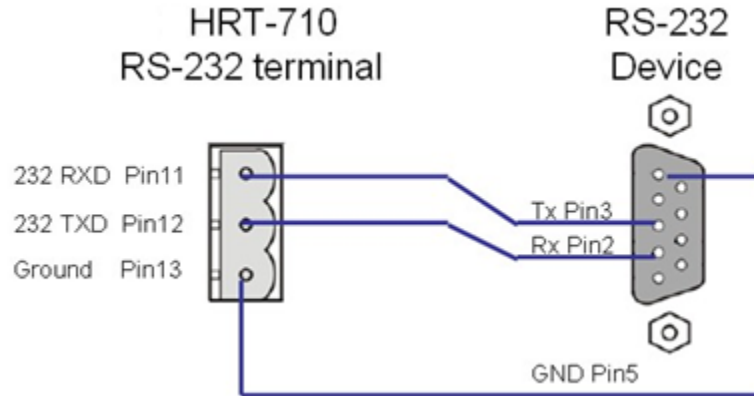

HART network wiring:

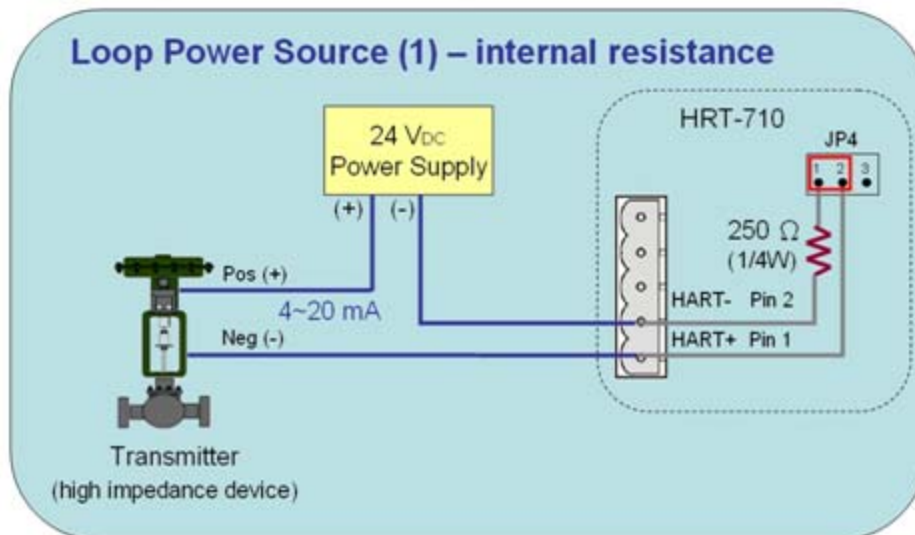

3. Install HG_Tool Utility

[Install .NET Compact Framework]

(1) When executing HG_Tool utility, the .NET Framework 2.0 or above must be installed first. If the .NET Framework 2.0 or above exists in the PC, please omit the step.

(2) User can download and Install .NET Compact Framework from the below website.

◆ Microsoft .Net Framework Version 2.0:

<http://www.microsoft.com/downloads/details.aspx?FamilyID=0856eacb-4362-4b0d-8edd-aab15c5e04f5&DisplayLang=en>

◆ Microsoft .Net Framework Version 3.5:

<http://www.microsoft.com/downloads/details.aspx?familyid=333325FD-AE52-4E35-B531-508D977D32A6&displaylang=en>

[Install HG_Tool.exe]

(1) Users can download the installation file of “HG_Tool” from the CD- (“CD:\hart\gateway\utilities\hg_tool\”) or ICP DAS web site:

[“ftp://ftp.icpdas.com.tw/pub/cd/fieldbus_cd/hart/gateway/utilities/hg_tool/”](ftp://ftp.icpdas.com.tw/pub/cd/fieldbus_cd/hart/gateway/utilities/hg_tool/)

(2) Execute the “setup.exe” file to install the “HG_Tool” utility.

(3) After finishing the installation of the HG_Tool, users can run the utility. (refer to the path in the below figure)



4. Communication test

Step 1: Connect PC, HRT-710 and HART slave device according to figure1.

Step 2: Set the DIP switch to the “default” position.

Step 3: Turn on the power of the HRT-710.

Step 4: Wait for the “RUN” LED indicator to be always on status. If the led always flashes, please check the HART network wiring. It means the HRT-710 can't connect to the HART slave devices.

Step 5: Execute the HG_Tool utility.

Step 6: Set the communication settings.

When the DIP switch is in the “default” position, the HRT-710 will adapt the follow communication settings of comport.

- [1] Protocol: MB RTU
- [2] Net ID: 1
- [3] Baud Rate: 115200 bps
- [4] Data Bits: 8
- [5] Stop Bits: 1
- [6] Parity: None

So the HG_Tool must have the same settings with the HRT-710 as shown in the below figure.

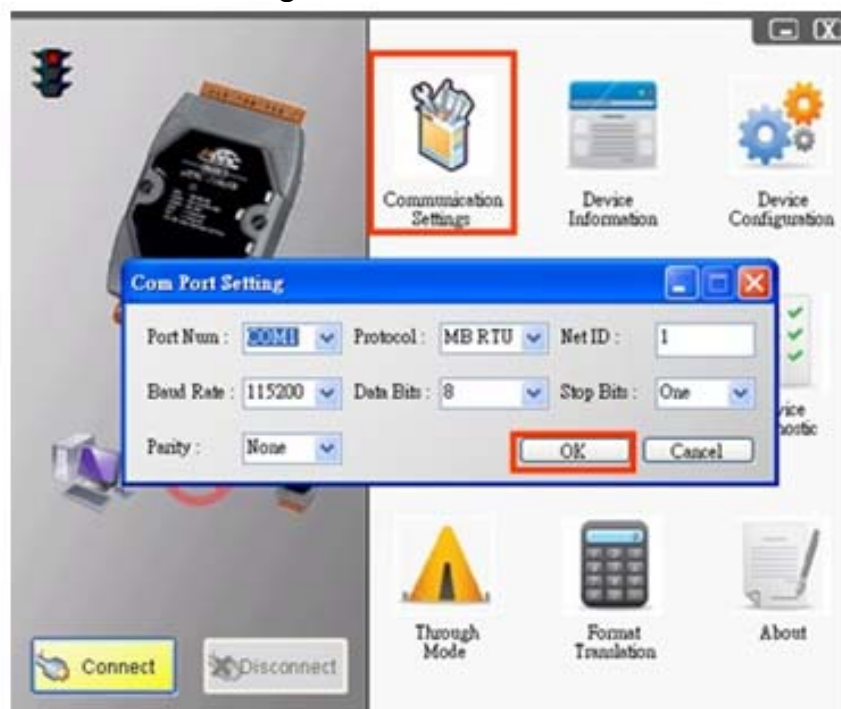

Step 7: Click “Connect” button.

Step 8: Wait for the traffic light changes into “green” light. If the traffic light always keeps in the “yellow” light, it means the PC can't connect to HRT-710, please check the RS-232 connection.

Step 9: Click the “Device Information” icon. Then select the default command or user command and right-click the mouse to choose

the “Basic Operation” option to get the information of the corresponding HART command.

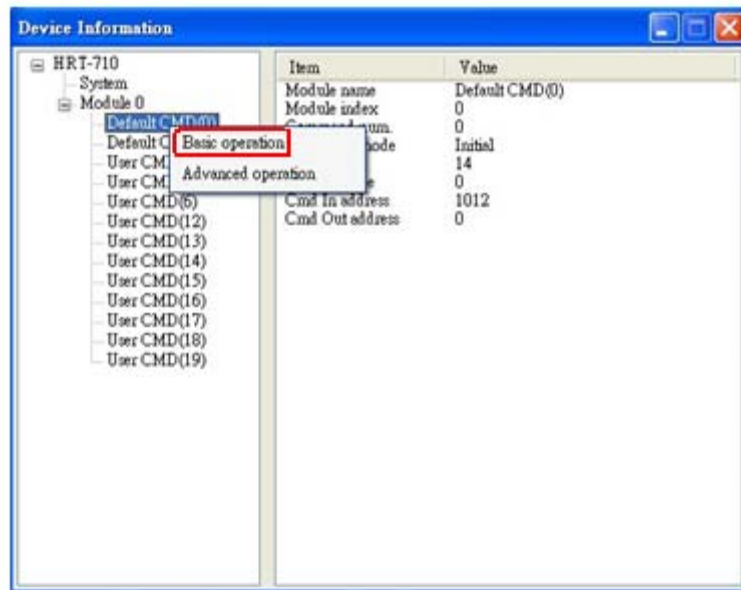

The information of HART command 0